

Komercijalni **Katalog**  
International **Catalogue**

**2014**



System 44



Jubilarna godišnjica



# Komercijalni katalog

## Short-Form Catalogue

AVE IS WIRING ACCESSORIES • TOUCH SYSTEM • HOME AUTOMATION • HOTEL AUTOMATION • ANTI-INTRUSION • FIRE DETECTION SYSTEM • VENTILATION SYSTEM • MODULAR DEVICES



VIDEOINTERFON  
VIDEO DOOR ENTRY



DIN  
MODULI  
MODULAR DEVICES



KUTIJE  
BOX



PROTIVPOŽARNI SISTEM  
FIRE DETECTION  
PROTIVPROVALNI SISTEM  
ANTI-INTRUSION



ELEKTROGALANTERIJA  
WIRING ACCESSORIES TOUCH



VENTILACIJA  
VENTILATION



HOTELSKI  
MENADŽMENT  
HOTEL MANAGEMENT



HOME AUTOMATION  
KUĆNA AUTOMATIKA

**AVE KATALOG:**  
TEHNIČKI I ESTETSKI INTEGRISAN ASORTIMAN PROIZVODA  
ZA SAVREMENU INSTALACIJU

**AVE CATALOGUE:**  
TECHNICALLY AND AESTHETICALLY INTEGRATED RANGES  
FOR ADVANCED INSTALLATIONS

# Smernice za čitanje kataloga

## Guide catalogue

8

**PREGLED podele proizvoda**  
*Products division overview*



**Sistema 45**

**DOMOTICA**  
HOME AUTOMATION

**GESTIONE ALBERGHERIA**  
HOTEL MANAGEMENT SYSTEMS

**DIVISIONE SICUREZZA**  
SAFETY - SECURITY

**VENTILAZIONE**  
VENTILATION

**SCATOLE CONTENITORI**  
CENTRALINI  
BOXES ENCLOSURE  
CONSOLMER UNITS

**APPARECCHI MODULARI**  
MODULAR DEVICES

**INDICE - NOTE**  
INDEX - NOTE

**Prikaz proizvoda koji se nalaze unutar poglavlja**

*Selection of products listed in each chapter*

**Naziv sektora**  
*Products division title*



**Sadržaj poglavlja**  
*Index*

**Obeleživač u boji, za lakšu identifikaciju sektora proizvoda**

*Coloured label for an easy identification of each products division*

**UNUTRAŠNJE STRANICE**  
*Inside pages*

Sledeće boje označavaju oblasti kojima pripadaju proizvodi:

*The following colours represent the four products divisions:*

**Elektrogalanterija**  
*Wiring accessories*

**Kućna automatika i hotelski menadžment**  
*Home Automation and Hotel Management Systems*

**Sigurnosni sistemi**  
*Safety-security division*

**Ventilacija**  
*Ventilation*

**Modularni uređaji**  
*Modular devices*

**Kutije, kućišta i razvodne table**  
*Boxes, enclosures, consumer units*

**Informacije o proizvodima**  
*Product information*



Obeleživač u boji za lakšu identifikaciju sektora proizvoda

*Coloured label for an easy identification of each products division*



**Opis proizvoda**  
*Product description*

**Minimalno i standardno pakovanje**

*Price, minimum package and standard package*

**Slika i kod proizvoda**  
*Picture and product code*

**Legenda simbola**  
*Symbols legend*



**Sistema 45**

**DOMOTICA**  
 HOME AUTOMATION

**QUESTIONE ALBERGHERIA**  
 HOTEL MANAGEMENT SYSTEMS

**DIVISIONE SICUREZZA**  
 SAFETY - SECURITY

**VENTILAZIONE**  
 VENTILATION

**SCATOLE CONTENITORI CENTRALI**  
 BOXES ENCLOSURES CONSUMER UNITS

**APPARECCHI MODULARI**  
 MODULAR DEVICES

**INDICE - NOTE**  
 INDEX - NOTE

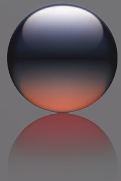

Dimenzije modula

Module dimensions

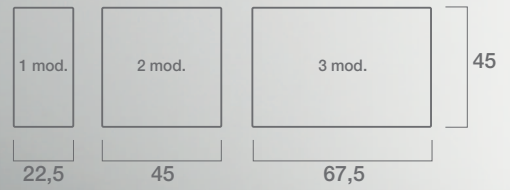

**Ave opremu mora da instalira obučeno lice, a tehničku ispravnost sistema mora da proverí stručno lice, u skladu sa važećim propisima**  
*Ave material must be installed by qualified people and the plant must be tested by an expert; according to regulations in force*

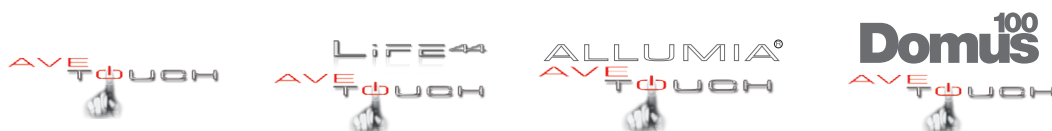

## Ave Touch

*Ave Touch*

### "SKRIVENA" REŠENJA

POTPUNO INOVATIVNO REŠENJE ZASNOVANO NA "NEVIDLJIVIM" MODULIMA OSETLJIVIM NA DODIR POVRŠINE MASKE OD STAKLA ILI ALUMINIJUMA



# 14

## Life Touch

*Life Touch*

### "HIDDEN" SOLUTIONS

ABSOLUTELY INNOVATIVE SOLUTION BASED ON "HIDDEN" MODULES SENSIBLE TO THE TOUCH OF THE GLASS OR ALUMINIUM FRONT PLATE SURFACE .



# 70

## Allumia Touch

*Allumia Touch*

### TRADICIONALNA REŠENJA

SERIJA MODERNOG DIZAJNA KOJU ČINE BROJNE TEHNOLOŠKE INOVACIJE I KOJA NUDI VELIKI BROJ INOVATIVNIH ESTETSKIH REŠENJA



# 70

## Domus Touch

*Domus Touch*

### TRADITIONAL SOLUTIONS

SERIES WITH AN ADVANCED DESIGN AND INNOVATIVE TECHNICAL DETAILS, AVAILABLE IN A WIDE RANGE OF AESTHETICAL PROPOSAL.

### TRADICIONALNA REŠENJA

SERIJA IZRADENA U SJAJNOSIVOJ BOJI OD MATERIJALA KOJI JE OTPORAN NA GREBANJE I OSTAVLJANJE OTISAKA PRSTJU, KOJA DOPRINOSI DA ENTERIJER ODIŠE MODERNOM I PREFINJENOM ATMOSFEROM

### TRADITIONAL SOLUTIONS

ALLUMIA PRODUCTS IN GLOSSY SILVER GREY COLOUR WITH ANTI-SCRATCH AND ANTI-FINGERPRINT SURFACE ARE ABLE TO GIVE YOUR HOME A REFINED AND MODERN FEATURE .



# 102

## Maske

*Front Plates*

### TRADICIONALNA REŠENJA

SERIJA INSPIRISANA TRADICIONALNIM I FUNKCIONALNIM DIZAJNOM, KOJA NUDI TEHNOLOŠKA I ESTETSKA REŠENJA POGODNA ZA BILO KOJU VRSTU PROSTORA

### TRADITIONAL SOLUTIONS

SERIE S INSPIRED BY THE TRADITIONAL AND FUNCTIONAL DESIGN, WITH TECHNOLOGICAL AND AESTHETICAL SOLUTIONS SUITABLE FOR ANY KIND OF ROOM .



# 130

## Armature i kućišta

*Frames and Enclosures*

### TRADICIONALNA REŠENJA

TRADITIONAL SOLUTIONS

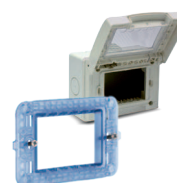

# 170



**Standardna armatura Sistema 44**  
System 44 Standard frame

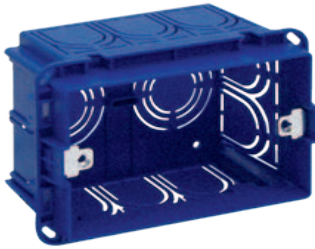
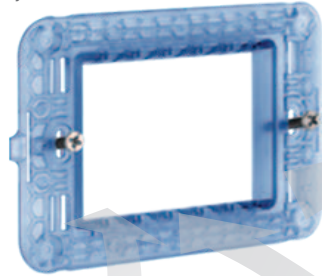

**Standardne pravougaone ugradne kutije**  
Standard flush-mounted rectangular boxes

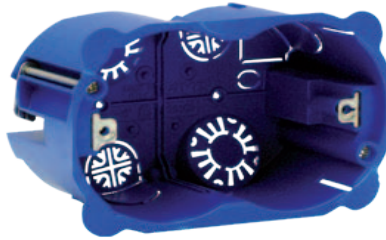

**Ave Touch "skriveni" modul**  
Ave Touch "Hidden" device



**Standardni Life Touch modul**  
Life Touch 44 standard device



**Maska Ave Touch**  
Ave Touch front plates



**Maska Ave Touch**  
Ave Touch front plates



**Maska Ave Touch**  
Ave Touch front plates

**MASKE SISTEMA 44**  
SYSTEM 44 FRONT PLATES



**Zama 44**



**Vera 44**



**Personal 44**

**Tecnopolimero 44**





Standardni Allumia Touch modul  
*Allumia Touch standard device*



Standardni Domus Touch modul  
*Domus Touch standard device*

MASKE SISTEMA 44  
SYSTEM 44 FRONT PLATES



Tecnopolimero 44



Vera 44



Zama 44



Personal 44



Tecnopolimero 44



Zama 44



Vera 44



Personal 44



Sistema 45





# AVE Touch rešenja

AVE Touch Solutions

NEW WIRING ACCESSORIES

Boje maski "Ave Touch" - AVE patenti N° 205, N° 209 i N° 212

"Ave Touch" front plate colours - AVE PATENTS N° 205, N° 209 AND N° 212

Dizajn: B. Dall'Eco  
Dizajn: L. Merletti

14

## Aluminijum Aluminium



**ALS**

Brušeni aluminijum  
Natural brushed aluminium



**ANS**

Tamni brušeni aluminijum  
Anthracite brushed aluminium

## Staklo Glass



**BL**

Sjajnobela  
Clear white

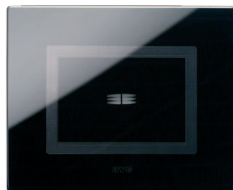

**NAL**

Sjajnocrna  
Clear absolute black



**GO**

Srebrnosiva mat  
Frosted silver grey



**RPL**

Sjajnocrvena  
Clear Pompeian red



**VO**

Vodnozelena  
Frosted water green

"Giugiaro Architettura"  
specijalne AVE Touch maske  
"Giugiaro Architettura"  
Ave Touch special front plates



**GIUGIARO**  
ARCHITETTURA

### Napomena

Specijalne boje i "Giugiaro" verzija maske mogu se dobiti samo po porudžbini, ne nalaze se u zalihama. Za uslove isporuke kontaktirajte AVE prodajnu mrežu.

The special colours and "Giugiaro" version front plates that are not in stock can be supplied upon request. For delivery terms, please contact AVE sales department

## Spoljašnji okvir Finishing ring

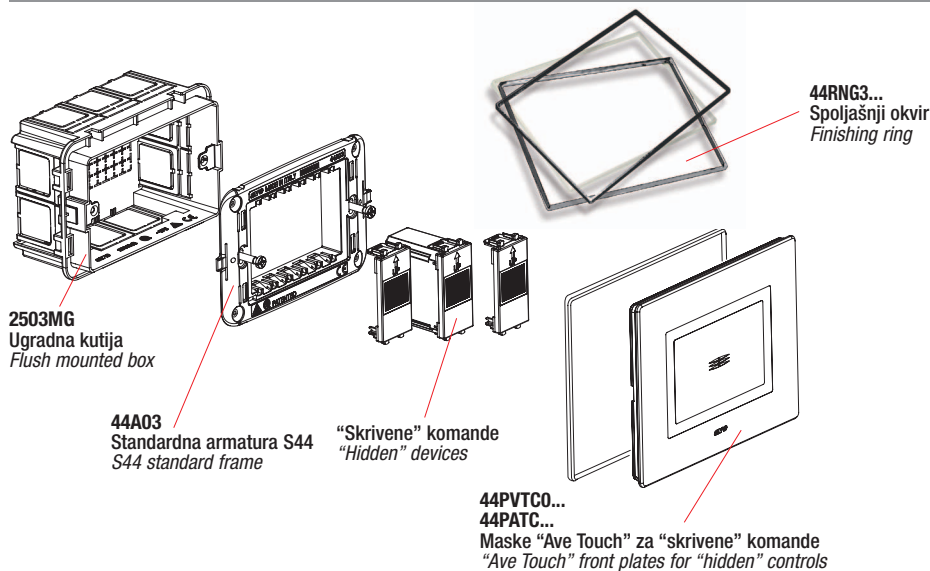

**Kompletiranje sistema sa modulima Allumia Touch i aluminijumskim maskama Vera 44**  
*Finishing with Allumia Touch devices and Vera 44 aluminium front plates*

Ave Touch rešenja    Ave Touch Solutions    Allumia Touch moduli    Allumia Touch devices



**Kompletiranje sistema sa modulima Life Touch i staklenim maskama Vera 44**  
*Finishing with Life Touch devices and Vera 44 glass front plates*

Ave Touch rešenja    Ave Touch Solutions    Life Touch moduli    Life Touch devices

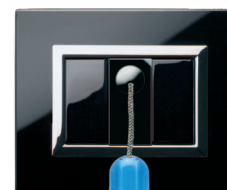
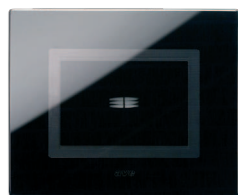

**Kompletiranje sistema sa modulima Domus Touch i staklenim maskama Vera 44**  
*Finishing with Domus Touch devices and Vera 44 glass front plates*

Ave Touch rešenja    Ave Touch Solutions    Domus Touch moduli    Domus Touch devices





# AVE Touch rešenja

AVE Touch Solutions

NEW WIRING ACCESSORIES

Aluminijumske maske "Ave Touch" - AVE PATENTI N° 205, N° 209 i N° 212  
"Ave Touch" aluminium front plates - AVE PATENTS N° 205, N° 209 AND N° 212

Dizajn: B. Dall'Eco  
Design: L. Merletti

16

## Okrugla/kvadratna kutija Round/square box

## Pravougaona kutija za 3 modula 3 modules rectangular box



**44PATC22ALS**  
Do 2 "skrivenih" komande  
Up to 2 "hidden" controls



**44PATC22ANS**  
Do 2 "skrivenih" komande  
Up to 2 "hidden" controls



**44PATC3ALS**  
Do 3 "skrivenih" komande  
Up to 3 "hidden" controls



**44PATC3ANS**  
Do 3 "skrivenih" komande  
Up to 3 "hidden" controls

## Pravougaona kutija za 4 modula 4 modules rectangular box

## Pravougaona kutija za 6/7 modula 6/7 modules rectangular box



**44PATC4ALS**  
Do 4 "skrivenih" komande  
Up to 4 "hidden" controls



**44PATC4ANS**  
Do 4 "skrivenih" komande  
Up to 4 "hidden" controls



**44PATC7ALS**  
Do 7 "skrivenih" komandi  
Up to 7 "hidden" controls



**44PATC7ANS**  
Do 7 "skrivenih" komandi  
Up to 7 "hidden" controls

## Pravougaona kutija za 3 modula 3 modules rectangular box



**44PATC16ALS**  
Za multi-touch modul sa 6 (3+3) "skrivenih" komandi  
For multi-touch module 6 (3+3) "hidden" controls



**44PATC16ANS**



**44PATC88ALS**  
Za 1 "skriveni" taster sa prozorčićem za karticu sa imenom  
For "hidden" push button module with name tag



**44PATC88ANS**



**44PATC76ALS**  
Za "skrivenu" personalizujuću svetlosnu signalizaciju  
For "hidden" light signal/lighting module customizable



**44PATC76ANS**

## Pravougaona kutija za 3 modula 3 modules rectangular box



**44PATCS3ALS**  
Klizna maska za 3 modula Sistem 44 sa simbolom utičnice na prednjoj strani  
Sliding for covering 3 standard modules S44 - front plug symbol



**44PATCS3ANS**  
Klizna maska za 3 modula Sistem 44 sa simbolom utičnice na prednjoj strani  
Sliding for covering 3 standard modules S44 - front plug symbol



**44PATCN3ALS**  
Klizna maska za 3 modula Sistem 44 bez simbola na prednjoj strani  
Sliding for covering 3 standard modules S44 - no front symbol



**44PATCN3ANS**  
Klizna maska za 3 modula Sistem 44 bez simbola na prednjoj strani  
Sliding for covering 3 standard modules S44 - no front symbol

## Pravougaona kutija za 3 modula 3 modules rectangular box



**44PATC3ALS/DA**  
Olakšane komande za osobe sa posebnim potrebama - personalizujuća  
Easier control for disabled - customizable



**44PATC3ANS/DA**  
Olakšane komande za osobe sa posebnim potrebama - personalizujuća  
Easier control for disabled - customizable



**44PA3ALS/FM**  
Maska za 3 modula Sistem 44 za instalaciju u ravni sa zidom  
3 standard modules S44 for wall-lined installations



**44PA3ANS/FM**  
Maska za 3 modula Sistem 44 za instalaciju u ravni sa zidom  
3 standard modules S44 for wall-lined installations

## Uputstva za postavljanje aluminijumskih "Ave Touch" maski "Ave Touch" aluminium front plates installation instructions

### ZAMENA STAKLA NA MASKI

Da bi se zamenilo staklo bez simbola koje je postavljeno sa prednje strane maske sa staklom na kome se nalaze simboli za identifikaciju komande, postupite prema instrukcijama koje su prikazane na slici pored

#### FRONT GLASS REPLACEMENT

To replace the clear front glass installed on the plate with a lasered front glass for identification of the control area proceed following the below instructions

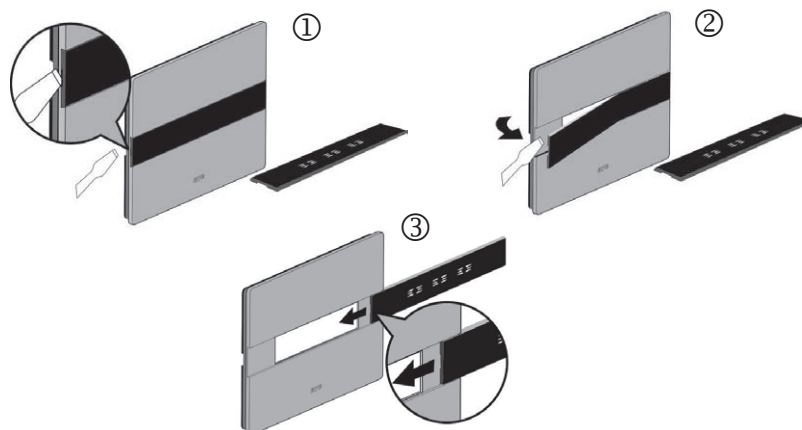

### VAŽNO!

Proverite da li je na površini "skrivenog" Ave Touch uređaja koji se koristi sa aluminijumskom maskom (na strani na kojoj se nalazi i šifra uređaja) prikazan simbol "#"(vidi sliku prikazanu pored)

#### IMPORTANT!

Check that Ave Touch "hidden" devices to be used with the aluminium plate are marked on the body (side of the device where the product code is) with symbol "# (see image)

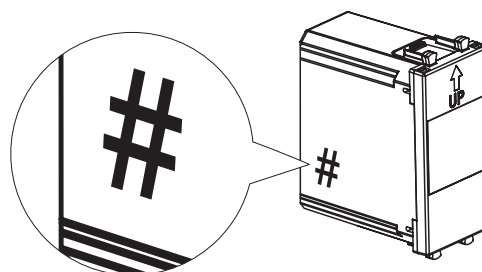

### VAŽNO!

#### Osetljivost Ave Touch uređaja

Kako bi se mogao garantovati pravilan rad "skrivenog" Ave Touch uređaja sa aluminijumskom maskom, na samom uređaju treba podesiti maksimalnu osetljivost (pogledaj sliku koja je prikazana pored kao i instrukcije koje se odnose na ovaj proizvod, paragraf PROGRAMIRANJE)

#### IMPORTANT!

#### Ave Touch device sensitivity

In order to grant proper functionality of Ave Touch "hidden" devices with the aluminium plate it is necessary to set on the devices the maximum sensitivity (see instructions attached to the product, PROGRAMMING paragraph)

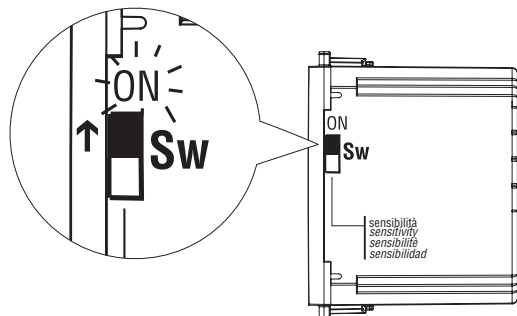

## Horizontalna i vertikalna instalacija maski "AVE TOUCH" i maski "Vera44"

Horizontal and Vertical "AVE TOUCH" and "Vera44" front plates installation

Na primer 2503MG + BLAS25  
IN THE EXAMPLE 2503MG + BLAS25

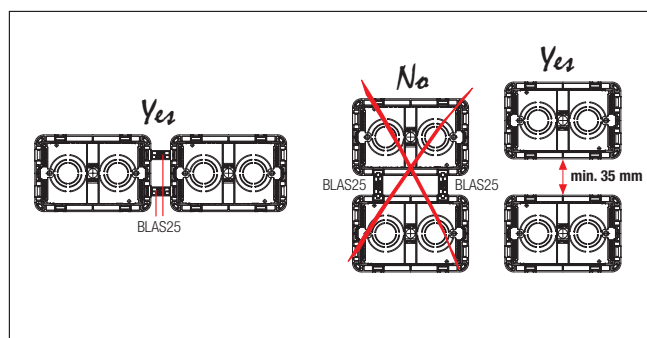

Na primer 2503MG + BLAS35  
IN THE EXAMPLE 2503MG + BLAS35

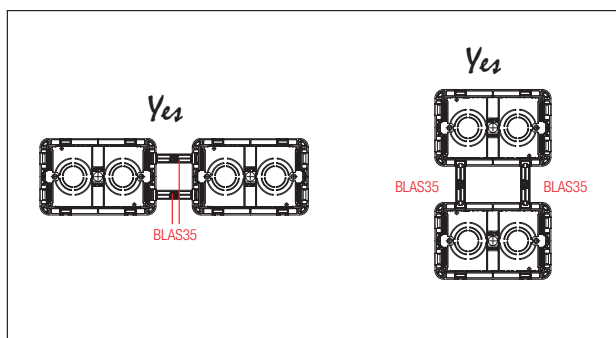



Okrugla/kvadratna kutija Round/square box

Pravougaona kutija za 3 modula 3 modules rectangular box



**44PVT C21...**  
Za 1 "skrivenu" komandu  
For 1 "hidden" control



**44PVT C22...**  
Za 2 "skrivenih" komande  
For 2 "hidden" controls



**44PVT C01...**  
Za 1 "skrivenu" komandu  
For 1 "hidden" control



**44PVT C01.../P**  
Za 1 "skrivenu" komandu sa prozorčićem personalizaciju simbola  
For 1 "hidden" control window for customization labels

Pravougaona kutija za 3 modula 3 modules rectangular box



**44PVT C02...**  
Za 2 "skrivenih" komande  
For 2 "hidden" controls



**44PVT C02.../P**  
Za 2 "skrivenih" komande sa prozorčićem personalizaciju simbola  
For 2 "hidden" controls windows for customization labels



**44PVT C3...**  
Za 3 "skrivenih" komande  
For 3 "hidden" controls



**44PVT C3.../P**  
Za 3 "skrivenih" komande sa prozorčićem personalizaciju simbola  
For 3 "hidden" controls windows for customization labels

Pravougaona kutija za 4 modula 4 modules rectangular box



**44PVT C03...**  
Za 3 "skrivenih" komande  
For 3 "hidden" controls



**44PVT C03.../P**  
Za 3 "skrivenih" komande sa prozorčićem personalizaciju simbola  
For 3 "hidden" controls windows for customization labels



**44PVT C4...**  
Za 4 "skrivenih" komande  
For 4 "hidden" controls

Pravougaona kutija za 6/7 modula 6/7 modules rectangular box

Kutija BL02P BL02P box



**44PVT C04...**  
Za 4 "skrivenih" komande  
For 4 "hidden" controls



**44PVT C7...**  
Za 7 "skrivenih" komandi  
For 7 "hidden" controls



**44PVT C33...**  
Za 6 (3+3) "skrivenih" komandi  
For 6 (3+3) "hidden" controls

Pravougaona kutija za 3 modula 3 modules rectangular box

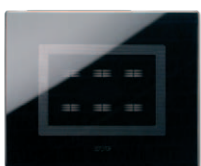

**44PVT C16...**  
Za multi-touch modul sa 6 (3+3) "skrivenih" komandi  
For multi-touch module 6 (3+3) "hidden" controls



**44PVT C88...**  
Za "skriveni" taster sa mestom za karticu za ime  
For 1 "hidden" push-button with name tag module



**44PVT C76...**  
Za "skrivenu" personalizujuću svetlosnu signalizaciju/svetiljku  
For customizable "hidden" light signal/lighting module



**44PVT C33...**  
Klizna maska za 3 modula Sistem 44 sa simbolom utičnice na prednjoj strani  
Sliding for covering 3 standard modules S44 front "plug" symbol



**44PVT C33...**  
Klizna maska za 3 modula Sistem 44 bez simbola na prednjoj strani  
Sliding for covering 3 standard modules S44 no front symbol

**Napomena**

Zamenite tačkice u šifri slovima koja odgovaraju željenoj boji maske (vidi maske na stranici 14)  
Replace the dots with the letters corresponding to the color (see front plates page 14)



Sistema 45

Okrugla/kvadratna kutija Round/square box

Pravougaona kutija za 3 modula 3 modules rectangular box



**44PVTc21...**  
 Za 1 "skrivenu" komandu  
 For 1 "hidden" control



**44PVTc22...**  
 Za 2 "skrivenih" komande  
 For 2 "hidden" controls



**44PVTc01...**  
 Za 1 "skrivenu" komandu  
 For 1 "hidden" control



**44PVTc01.../P**  
 Za 1 "skrivenu" komandu sa prozorčićem  
 za personalizaciju simbola  
 For 1 "hidden" control  
 window for customization labels

Pravougaona kutija za 3 modula 3 modules rectangular box



**44PVTc02...**  
 Za 2 "skrivenih" komande  
 For 2 "hidden" controls



**44PVTc02.../P**  
 Za 2 "skrivenih" komande sa prozorčićem  
 za personalizaciju simbola  
 For 2 "hidden" controls  
 windows for customization labels



**44PVTc3...**  
 Za 3 "skrivenih" komande  
 For 3 "hidden" controls



**44PVTc3.../P**  
 Za 3 "skrivenih" komande sa prozorčićem  
 za personalizaciju simbola  
 For 3 "hidden" controls  
 windows for customization labels

Pravougaona kutija za 4 modula 4 modules rectangular box



**44PVTc03...**  
 Za 3 "skrivenih" komande  
 For 3 "hidden" controls



**44PVTc03.../P**  
 Za 3 "skrivenih" komande sa prozorčićem  
 za personalizaciju simbola  
 For 3 "hidden" controls windows for customization labels



**44PVTc4...**  
 Za 4 "skrivenih" komande  
 For 4 "hidden" controls

Pravougaona kutija za 6/7 modula 6/7 modules rectangular box

Kutija BL02P BL02P box



**44PVTc04...**  
 Za 4 "skrivenih" komande  
 For 4 "hidden" controls



**44PVTc7...**  
 Za 7 "skrivenih" komandi  
 For 7 "hidden" controls



**44PVTc33...**  
 Za 6 (3+3) "skrivenih" komande  
 For 6 (3+3) "hidden" controls

Pravougaona kutija za 3 modula 3 modules rectangular box



**44PVTc16...**  
 Za multi-touch modul sa 6 (3+3)  
 "skrivenih" komandi  
 For multi-touch module 6 (3+3)  
 "hidden" controls



**44PVTc88...**  
 Za "skriveni" taster sa mestom  
 za karticu za ime  
 For 1 "hidden" push-button  
 with name tag module



**44PVTc76...**  
 Za "skrivenu" personalizujuću  
 svetlosnu signalizaciju/svetiljku  
 For customizable "hidden"  
 light signal/lighting module



**44PVTcS3...**  
 Klizna maska za 3 modula  
 Sistem 44 sa simbolom utičnice  
 na prednjoj strani  
 Sliding for covering 3 standard  
 modules S44 front "plug" symbol



**44PVTcN3...**  
 Klizna maska za 3 modula  
 Sistem 44 bez simbola  
 na prednjoj strani  
 Sliding for covering 3 standard  
 modules S44 no front symbol

**Napomena**

Zamenite tačkice u šifri slovima koja odgovaraju željenoj boji maske (vidi maske na stranici 14)  
 Replace the dots with the letters corresponding to the color (see front plates page 14)



# AVE Touch rešenja

## AVE Touch Solutions

### Prekidači "na dodir" - "skrivena" instalacija "Touch" switches - "hidden" installation

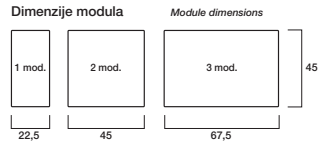

PATENTI AVE N° 208 i N° 211  
AVE PATENTS N° 208 AND N° 211

20

Opis      Description

Info      €



442TC01  
442TC01/2F

#### 442TC01

Elektronski prekidač sa relejnim izlazom 1P NO 10A 230V~ - upravljanje dodirivanjem prednje površine ili sa različitih lokacija pomoću klasičnih NO tastera - monostabilni ili bistabilni režim rada - LED male potrošnje za lociranje u mraku - memorisanje statusa relejnog izlaza u slučaju nestanka električne energije - napajanje 230V ~ - koristi se sa maskama "Ave touch" - 1 "skriveni" modul

1 1

*Electronic touch switch - relay output 1P NO 10A 230V~ - controlled by touching the frontal area or from multiple points with NO buttons - monostable or bistable operating mode - low consumption led for identification in the dark - output relay status memorization in case of black out - 230V~ power supply - to be coupled with Ave "Touch" front plate - 1 "hidden" module*

#### 442TC01/2F

Elektronski prekidač 230V~ - na dve žice sa triak izlazom za rezistivne i induktivne potrošače (inkadescence i halogene svetiljke 40-400W, feromagnetne transformatore za halogene svetiljke niskog napona 40-400VA, induktivne elektronske transformatore 40-300VA tipa OSRAM HALOTRONIC HTM 70/230-240, HTM 105/230-240, HTM 150/230-240) - upravljanje dodirivanjem prednje površine ili sa različitih lokacija pomoću klasičnih NO tastera - bistabilni režim rada - LED male potrošnje za lociranje u mraku - memorisanje statusa relejnog izlaza u slučaju nestanka električne energije - koristi se sa maskama "Ave touch" - 1 skriveni modul

1 1

*Electronic touch switch "2 wires" 230V~ with Triac output for resistive and inductive loads (40-400W incandescent and halogen lamps, ferromagnetic transformers for low voltage 40-400 VA halogen lamps, electronic inductive transformer type 40-300VA OSRAM HALOTRONIC HTM 70/230-240, HTM 105/230-240, HTM 150/230-240) - controlled by touching the frontal area or from multiple points with NO normal buttons - bistable operating mode - low consumption led for identification in the dark - output status memorization in case of black out - to be coupled with Ave "Touch" front plate - 1 "hidden" module*

**Napomena:** ✓ 442TC01/2F: ne preporučuje se instalacija više od jednog prekidača u istu instalacionu kutiju  
✓ mogućnost podešavanja nivoa osetljivosti uređaja: dodirrom maske ili na 4 mm od maske

**Note:** ✓ 442TC01/2F: it is recommended not to install more than one switch in the same box  
✓ it is possible to set the sensitivity of the device: by touching the plate or at a distance of 4mm from the plate itself

**Upozorenje:** neophodno je poštovati radni napon koji je naznačen u uputstvu za upotrebu.

**U suprotnom, može doći do oštećenja uređaja**

**Warning: it is essential to respect the operational voltage indicated on the coupon otherwise you can damage the devices**

Šeme povezivanja

Connection Diagram

442TC01

442TC01/2F

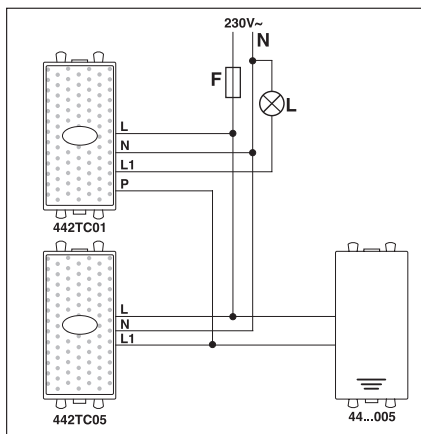

L: potrošač  
F: osigurač tipa F 10A H 250V~  
L: load  
F: fuse type F 10A H 250V~

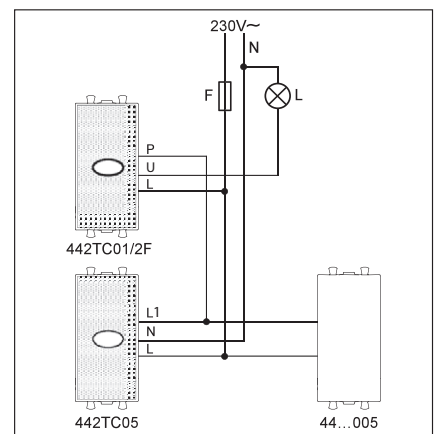

L: potrošač  
F: osigurač tipa F 2A H 250V~  
L: load  
F: fuse type F 2A H 250V~



Za raspoloživost kontaktirajte Ave distributere  
For availability please contact sales dept.



Dostupni dok se ne rasprodaju zalihe  
Available until stock out



Proizvod za pravougaone kutije britanskog standarda  
Product for British standard rectangular box



Proizvod za izvoz  
For Export only

# Prekidači "na dodir" - "skrivena" instalacija

## "Touch" switches - "hidden" installation

AVE PATENTI N° 208 i N° 211  
AVE PATENTS N° 208 AND N° 211

21



442TC01/12V

Opis Description

Info €

1 1

### 442TC01/12V

Elektronski prekidač sa relejnim izlazom 1P NO 2A 230V~ - **beznaponski** - upravljanje dodirivanjem prednje površine ili sa različitim lokacija pomoću klasičnih NO tastera - monostabilni i bistabilni režim rada - LED male potrošnje za lociranje u mraku - memorisanje statusa relejnog izlaza u slučaju nestanka električne energije - napajanje 12÷24Vac/dc - smanjena dubina - koristi se sa maskama "Ave touch" - 1 "skriveni" modul

*Electronic touch switch - relay output 1P NO 2A 230V~ - potential free - controlled by touching the frontal area or from multiple points with NO buttons - monostable or bistable operating mode - low consumption led for identification in the dark - output relay status memorization in case of black out - 12÷24Vac/dc power supply - to be coupled with Ave "Touch" front plate - 1 "hidden" module*

**Napomena:** mogućnost podešavanja nivoa osetljivosti uređaja - dodirrom maske ili na 4 mm od maske

**Note:** it is possible to set the sensitivity of the device: by touching the plate or at a distance of 4mm from the plate itself

### Šeme povezivanja

### Connection Diagram

442TC01/12V

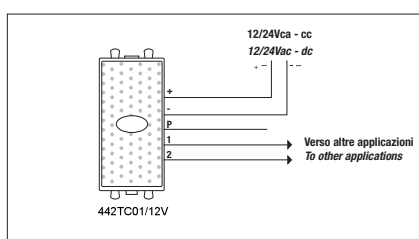
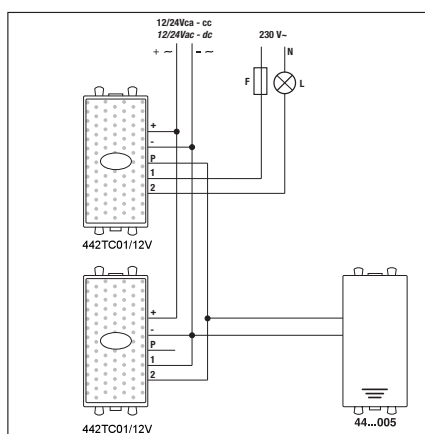

L: potrošač  
F: osigurač tipa F 5A H 250V~  
L: load  
F: fuse type F 5A H 250V~

### Primeri instalacije

### Installation Examples

#### "Skrivene" komande

#### "Hidden" devices

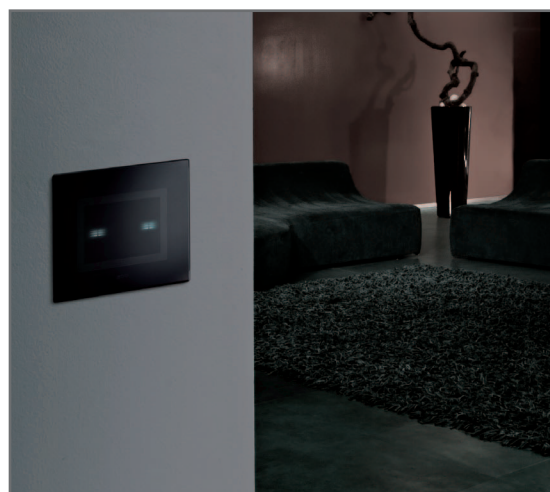
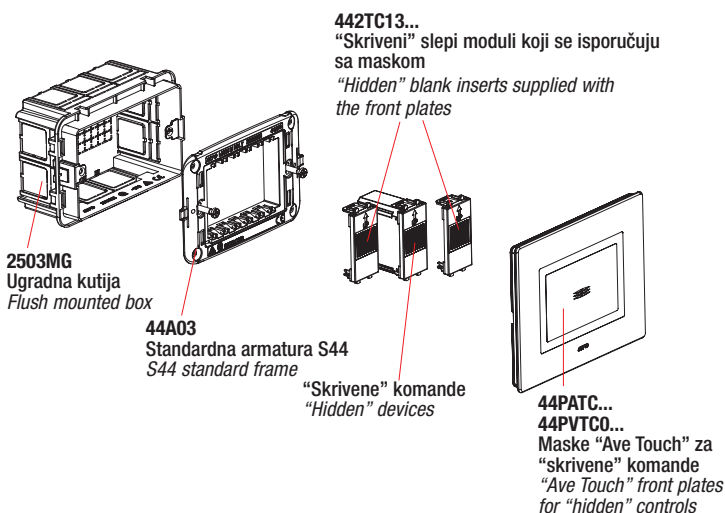

Mln. pakovanje kom.  
Min. Packaging pcs

Stand. pakovanje kom.  
Std. Packaging pcs





442TC05

Upozorenje: neophodno je poštovati radni napon koji je naznačen u uputstvu za upotrebu. U suprotnom, može doći do oštećenja uređaja.

**Warning: it is essential to respect the operational voltage indicated on the coupon. Otherwise you can damage the devices**

#### 442TC05

Elektronski taster za udaljenu kontrolu Ave Touch uređaja, sa senzorom osetljivim na dodir - upravljanje dodirivanjem prednje površine - monostabilni režim rada - LED male potrošnje za lociranje u mraku - napajanje 230V~ - koristi se sa elektronskim prekidačima 442TC01, 442TC01/2F, sa dimerom na dodir 442TC48 ili sa tasterom za roletne na dodir 442TC51 - koristi se sa maskama "Ave touch" - 1 "skriveni" modul

*Electronic push button for remote control with touch sensor - controlled by touching the frontal area - monostable operating mode - low consumption led for identification in the dark -230V~ - to be coupled with 442TC01, 442TC01/2F or 442TC48 touch dimmer - to be coupled with Ave "Touch" front plates - 1 "hidden" module*

**Napomena:** mogućnost podešavanja nivoa osetljivosti uređaja - dodirnom maske ili na 4 mm od maske

**Note:** It is possible to set the sensitivity of the device: at the touch of the plate or at a distance of 4 mm from the plate itself

1 1

Za verziju jednogkanalnog predajnika kućne automatike AVE Touch 442ABTC1 vidi stranicu 313  
FOR THE HOMEAUTOMATIONVERSION OF AVE TOUCH1 CHANNELTRANSMITTER CODE442ABTC1 SEE PAGE 313

#### Šeme povezivanja Connection Diagram

442TC05

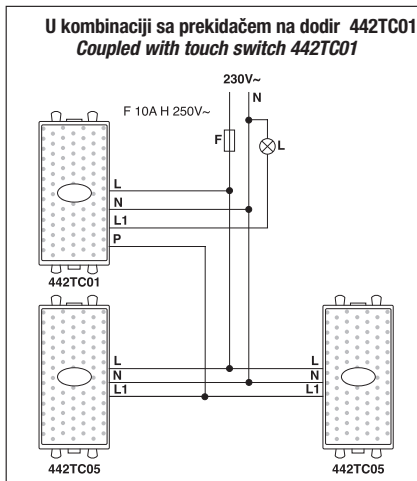

L: potrošač F: osigurač  
L: load F: fuse

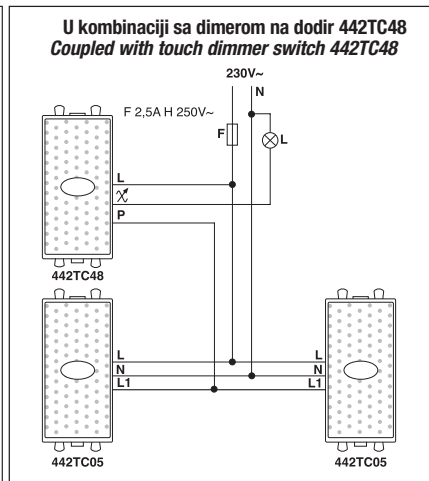

L: potrošač F: osigurač  
L: load F: fuse

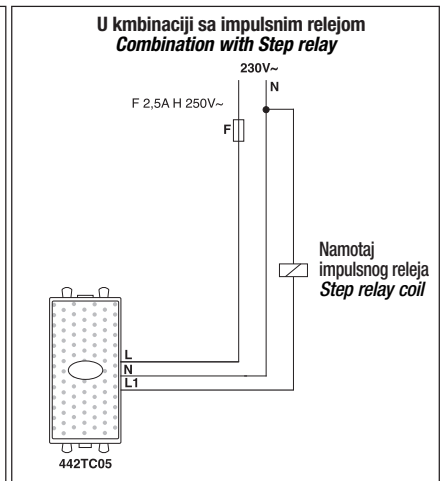

L: potrošač F: osigurač  
L: load F: fuse

**Direktno upravljanje elektromehaničkim zvonom 44..029 ili elektromehaničkom zujalicom 44..030**  
*Direct control of electromechanical ringing bells code 44..029 or electromechanical buzzers 44..030*

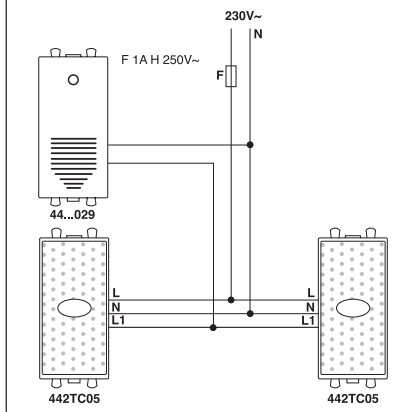

L: potrošač F: osigurač  
L: load F: fuse

#### Primer instalacije Installation Examples

##### "Skrivene" komande "Hidden" devices

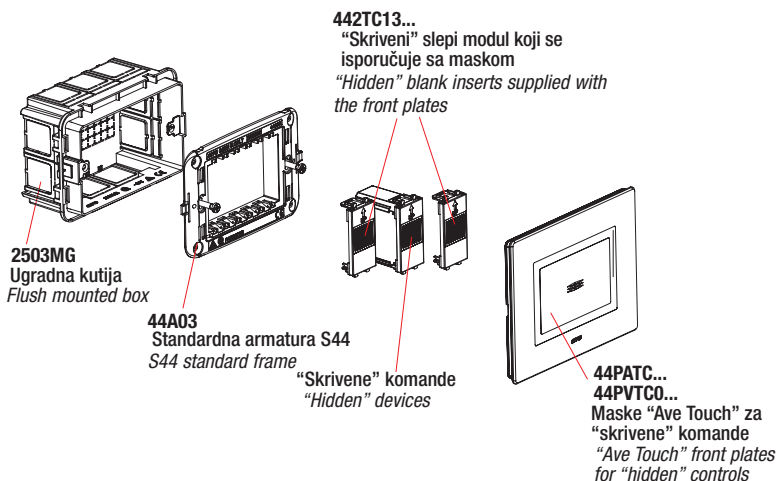

Za raspoloživost kontaktirajte Ave distributere  
For availability please contact sales dept.



Dostupni dok se ne rasprodaju zalihe  
Available until stock out



Proizvod za pravougaone kutije britanskog standarda  
Product for British standard rectangular box



Proizvod za izvoz  
For Export only

## Dvosmerni taster za roletne 230V~ "na dodir" - "skrivena" instalacija "Touch" rolling blind switch - "hidden" installation

PATENTI AVE N° 208 i N° 211  
AVE PATENTS N° 208 AND N° 211

Opis	Description	Info	€
 <b>442TC51</b>  Upozorenje: neophodno je poštovati radni napon koji je naznačen u uputstvu za upotrebu. U suprotnom, može doći do oštećenja uređaja.  <b>Warning: it is essential to respect the operational voltage indicated on the coupon. Otherwise you can damage the devices</b>	<b>442TC51</b> Elektronski taster za roletne osetljiv na dodir sa 2 monostabilna relejna izlaza NO 2A 230V ~ -upravljanje dodirivanjem prednje površine ili sa različitim lokacija pomoću klasičnih NO tastera - monostabilni ili vremenski programiran režim rada - LED male potrošnje za lociranje u mraku - napajanje 230V~ - koristi se sa maskama "Ave touch" - 1 "skriveni" modul <i>Electronic touch rolling blind switch with 2 monostable relay output, NO contact 2A 230V~ - Controlled by touching the frontal area of the glass plate or from multiple points with NO buttons - Monostable or bistable operating mode - Low consumption LED for identification in the dark - 230V~ power supply - to be coupled with AVE "Touch" front plates - 1 "hidden" module</i>	1	1
<b>Napomena: mogućnost podešavanja nivoa osetljivosti uređaja - dodirrom maske ili na 4 mm od maske</b> <b>Note: It is possible to set the sensitivity of the device: at the touch of the plate or at a distance of 4 mm from the plate itself</b>			

### Šema povezivanja Connection Diagram

442TC51

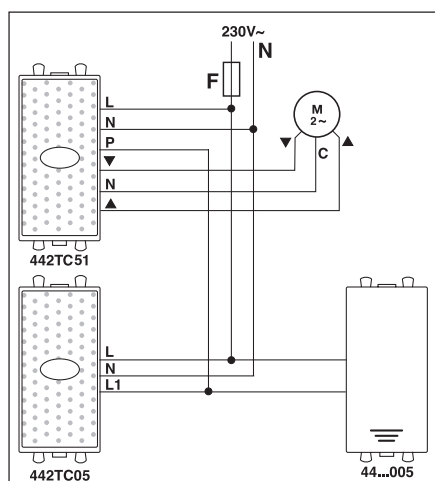

L: potrošač  
F: osigurač tipa F 2A H 250V~  
L: load  
F: fuse type F 2A H 250V~

### Primeri instalacije Installation Examples

"Skrivene" komande "Hidden" devices

**2503MG**  
Ugradna kutija  
Flush mounted  
boxes

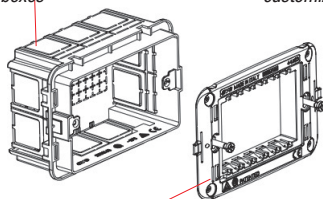

**44A03**  
Standardna armatura S44  
S44 standard frame

**ETI16**  
**ETI16B**  
**ETI16GR**  
Izmenjive etikete za  
personalizaciju  
Interchangeable labels for  
customization

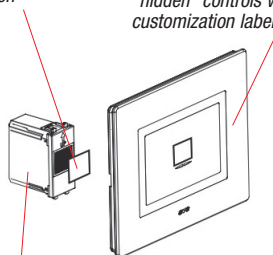

"Skriveni" dvosmerni taster za roletne  
"Hidden" rolling blind switch

**44PVT0.../P**  
Maska "Ave Touch" za upravljanje  
"skrivenim" komandama sa  
prozorom za etikete za  
personalizaciju  
"Ave Touch" front plate for  
"hidden" controls with windows for  
customization label



Mln. pakovanje kom.  
Min. Packaging pcs

Stand. pakovanje kom.  
Std. Packaging pcs



# AVE Touch rešenja

## AVE Touch Solutions



### Multi-touch komande "na dodir" - "skrivena" instalacija "Multi-Touch" controls - for "hidden" installation

PATENTI AVE N° 208 I N° 211  
AVE PATENTS N° 208 AND N° 211

24

Opis *Description*

Info €

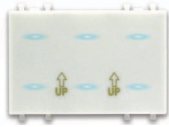

442TC16

#### 442TC16

**Novo**

1 1

Multi-touch elektronska komanda sa 6 monostabilnih beznaponskih relejnih izlaza 1P NO 2A 230V~ - upravljanje dodirivanjem prednje površine ili sa više lokacija pomoću NO tastera - režim rada izlaza: monostabilni, bistabilni i vremenski programirani, za roletne (sa interblokom funkcijom) - 9 LED lampica niske potrošnje sa prednje strane (od kojih istovremeno može biti uključeno maksimalno 6) za lakše lociranje u mraku - memorisanje stanja relejnih izlaza u slučaju nestanka napajanja - napajanje 100÷240V~ 50-60 Hz- koristi se sa maskom "Ave touch" - 3 "skrivena" modula

*Electronic multi-touch control - 6 monostable output-relay front 1P NO contact 2A 230V~  
Dry contact - controlled by touching the frontal area of the finishing plate or from multiple points with no push buttons - monostable, bistable or timed operating modalities, curtains with interlock - n. 9 low consumption front led for identification in the darkness (only 6 led switched on at the same time - saving output-relay status in case of blackout - powered 100÷240 Vac/dc ~ 50-60 HZ - to be coupled with Ave "Touch" front plate - 3 "hidden" gang.*

**Napomena:** mogućnost podešavanja nivoa osetljivosti uređaja - dodirrom maske ili na 4 mm od maske

**Note:** it is possible to set the sensitivity of the device: by touching the plate or at a distance of 4mm from the plate itself

#### Šema povezivanja *Connection Diagram*

442TC16

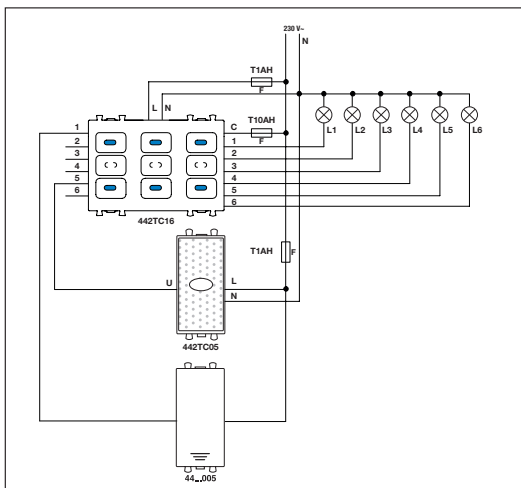

L1, L2, L3, L4, L5, L6: potrošač  
F: osigurač  
L1, L2, L3, L4, L5, L6: load  
F: fuse

#### Primer instalacije *Installation Examples*

##### Multi-Touch "skriveni" modul *"Hidden" multi-touch module*

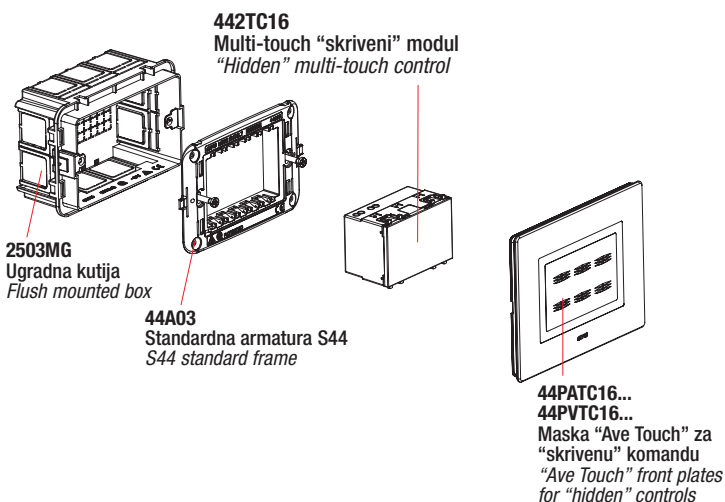

2503MG  
Ugradna kutija  
Flush mounted box

44A03  
Standardna armatura S44  
S44 standard frame

44PATC16...  
44PVTC16...  
Maska "Ave Touch" za  
"skrivenu" komandu  
"Ave Touch" front plates  
for "hidden" controls



Za raspoloživost kontaktirajte  
Ave distributere  
For availability please contact  
sales dept.



Dostupni dok se ne  
rasprodaju zalihe  
Available until stock out



Proizvod za pravougaone  
kutije britanskog standarda  
Product for British standard  
rectangular box



Proizvod za  
izvoz  
For Export  
only

**MULTI-TOUCH sa simbolima za personalizaciju**  
*MULTI-TOUCH with customizable symbols*



44PVC3NAL/XX



Ave Touch sistem je proširen novom modularnom multi-touch komandom (do šest nezavisnih komandi), koje korisnik može personalizovati. Personalizaciju maske moguće je izvršiti pomoću softvera koji se može preuzeti sa sajta **www.ave.it**.

A new modular multi-touch control (up to six independent controls) which can be customized by the user is now available in the **Ave Touch** system. It possible to customize the finish plates by a dedicated software downloaded from [www.ave.it](http://www.ave.it)



Sistema 45

FM				OFF	ON	ALARM	DO NOT DISTURB	RESET			
					2	3					





# AVE Touch rešenja

AVE Touch Solutions



## Regulator inteziteta svetlosti 230V~ "na dodir" - "skrivena" instalacija 230V~ "Touch" dimmer for lighting controls - "hidden" installation

PATENTI AVE N° 208 i N° 211  
AVE PATENTS N° 208 AND N° 211

26

Opis Description

Info €



442TC48

### 442TC48

Regulator inteziteta svetlosti 230V~ za rezistivne i induktivne potrošače (inkandescentne i halogene svetiljke 40-400W, feromagnetne transformatore za halogene svetiljke niskog napona 40-400VA, elektronske induktivne transformatore 40-300VA tipa OSRAM HALOTRONIC HTM 70/230-240, HTM 105/230-240, HTM 150/230-240) - upravljanje dodirivanjem prednje površine ili sa različitim lokacija pomoću klasičnih NO tastera - LED male potrošnje za lociranje u mraku - memorisanje statusa relejnog izlaza u slučaju nestanka električne energije - koristi se sa maskama "Ave touch" - 1 "skriveni" modul

230V~ dimmer for resistive and inductive loads (40-400W incandescent and halogen lamps, ferromagnetic transformers for low voltage 40-400 VA halogen lamps, electronic inductive transformer type 40-300VA OSRAM HALOTRONIC HTM 70/230-240, HTM 105/230-240, HTM 150/230-240) - control and regulation by touching the frontal area or from multiple points with normal NO buttons - low consumption led for identification in the dark - **output and level relay status memorization in case of black out** - to be coupled with "Ave Touch" front plates - 1 "hidden" module

Upozorenje: neophodno je poštovati radni napon koji je naznačen u uputstvu za upotrebu. U suprotnom, može doći do oštećenja uređaja.

**Warning: it is essential to respect the operational voltage indicated on the coupon. Otherwise you can damage the devices**

**Napomena:** ✓ ne preporučuje se instalacija više od jednog regulatora inteziteta svetlosti u istu kutiju  
✓ mogućnost podešavanja nivoa osetljivosti uređaja: dodirivanjem maske ili na 4 mm od maske

**Note:** ✓ it is recommended to not install more than one dimmer in the same box  
✓ It is possible to set the sensitivity of the device: by touching the plate or at a distance of 4mm from the plate itself

### Šema povezivanja

### Connection Diagram

442TC48

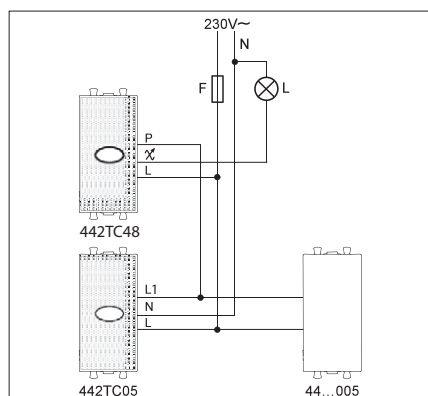

L: potrošač  
F: tip osigurača F 2A H 250V~  
L: load  
F: fuse type F 2A H 250V~

### Primeri instalacije

### Installation Examples

#### "Skrivene" komande

#### "Hidden" devices

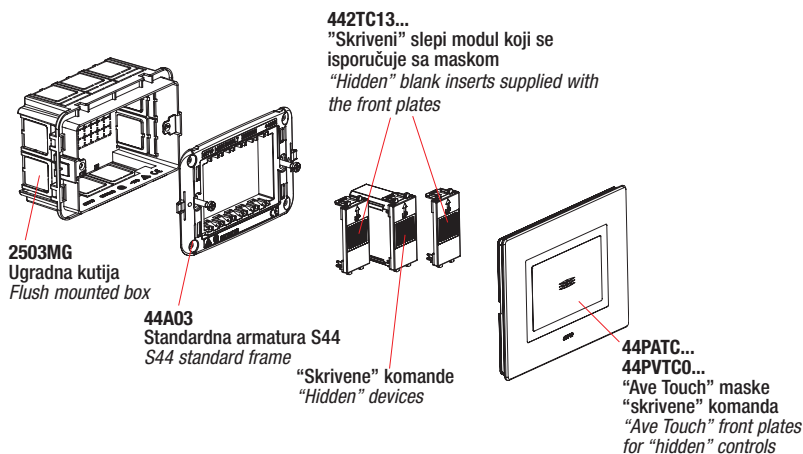

Za raspoloživost kontaktirajte Ave distributere  
For availability please contact sales dept.



Dostupni dok se ne rasprodaju zalihe  
Available until stock out



Proizvod za pravougaone kutije britanskog standarda  
Product for British standard rectangular box



Proizvod za izvoz  
For Export only

# Taster za zvono 230V~ "na dodir" - "skrivena" instalacija

## 230V~ "Touch" bell push button - "hidden" installation

PATENTI AVE N° 208 i N° 211  
AVE PATENTS N° 208 AND N° 211

27



442TC88

Upozorenje: neophodno je poštovati radni napon koji je naznačen u uputstvu za upotrebu. U suprotnom, može doći do oštećenja uređaja.

**Warning: it is essential to respect the operational voltage indicated on the coupon. Otherwise you can damage the devices**

### 442TC88

Elektronski taster sa personalizujućom pločicom za ime - relejni izlaz 1P NO 8A - upravljanje dodirivanjem prednje površine - monostabilna funkcija - LED za lociranje u mraku - napajanje 230V - mogućnost podešavanja inteziteta osvetljenja površine na koju se može postaviti folija sa imenom - zujalica (koja se može izostaviti) za potvrdu poziva - koristi se sa maskom "Ave touch" - 3 "skrivena" modula

*Electronic push button with customizable name tag - relay output 1P NO 8A - controlled by touching the frontal area - monostable operating mode - low consumption led for identification in the dark - 230V~ power supply - possibility to regulate the light intensity of the name tag area - buzzer (that can be excluded) for call confirmation - to be coupled with "Ave Touch" front Plates - 3 "hidden" modules*

**Napomena:** mogućnost podešavanja nivoa osetljivosti uređaja - dodirnom maske ili na 4 mm od maske

**Note:** It is possible to set the sensitivity of the device: by touching the plate or at a distance of 4mm from the plate itself

### Šeme povezivanja Connection Diagram

442TC88

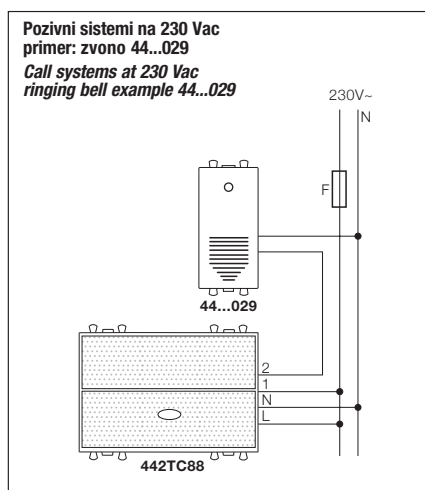

F: osigurač tipa F 1A H 250V~  
F: fuse type F 1A H 250V~

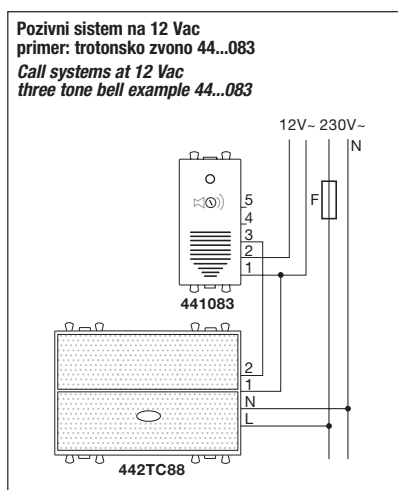

F: osigurač tipa F 1A H 250V~  
F: fuse type F 1A H 250V~

### Primeri instalacije Installation Examples

"Skriveni" taster za zvono sa pločicom za ime

"Hidden" push button with name tag

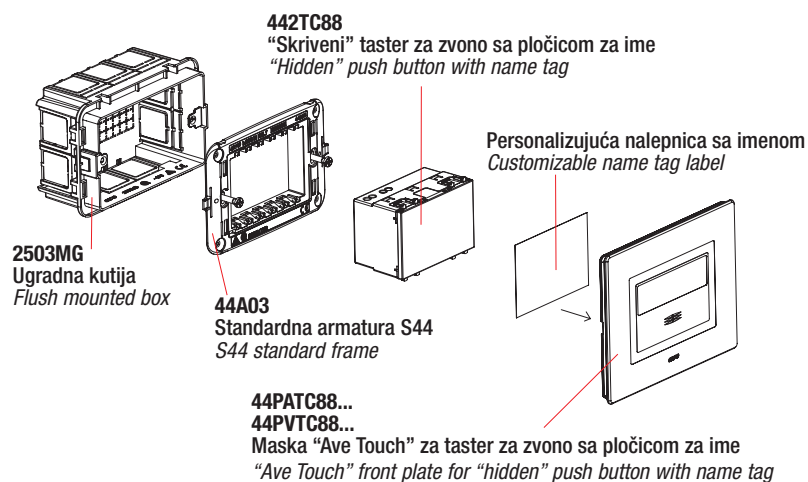



# AVE Touch rešenja

AVE Touch Solutions



## Optička signalizacija - "skrivena" instalacija Optical signal - "hidden" installation

PATENTI AVE № 208 i № 211  
AVE PATENTS № 208 AND № 211

28

Opis Description

Info €

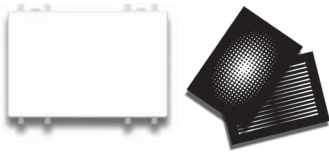

442TC76

### 442TC76

1 1

Personalizujuća svetlosna signalizacija/svetiljka - može se personalizovati pomoću izmenljivih folija sa različitim natpisima i simbolima prema izboru korisnika - napajanje 230V~ - mogućnost podešavanja inteziteta osvetljenja površine na koju se postavljaju folije za personalizaciju - mogu se koristiti za stepenišno osvetljenje, svetlo dobrodošlice, itd. - koristi se sa maskom "Ave touch" - 3 "skrivena" modula

*Customizable light signal/lighting - possibility to customize it with interchangeable labels with writings and symbols chosen by the user - 230V~ power supply - possibility to regulate the light intensity in the area for customized label - it can be used as stair riser light, courtesy light, etc.. - to be coupled with the proper "Ave Touch" front plate - 3 "hidden" modules*

**Napomena:** isporučuje se sa 2 folije različite optičke teksture

**Note:** supplied with 2 different optical texture films

### Šema povezivanja

### Connection Diagram

442TC76

### Primer upotebe

### Application example

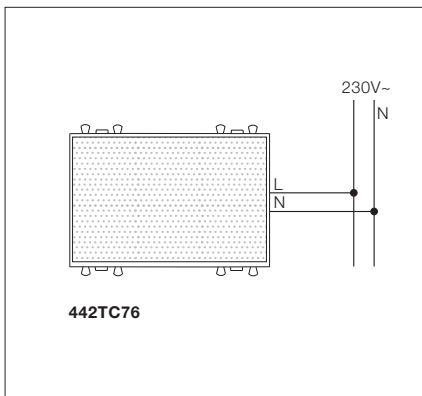

44PVT76NAL + PEL01

### Primer instalacije

### Installation Examples

### "Skrivena" svetlosna signalizacija/svetiljka

### "Hidden" light signal/lighting

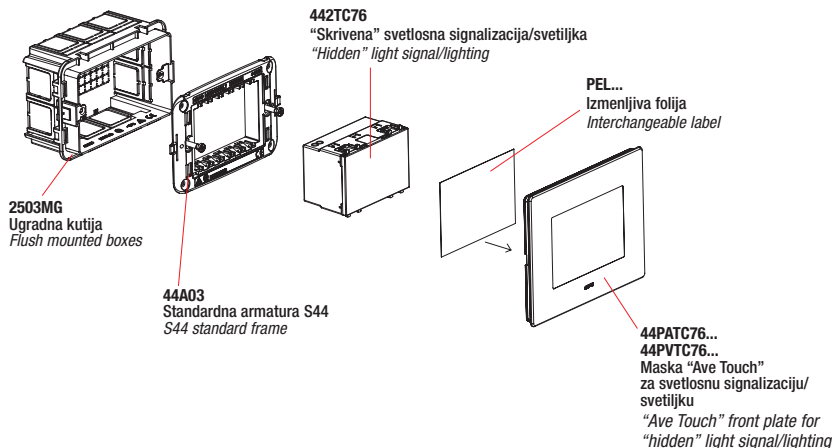

Za raspoloživost kontaktirajte Ave distributere  
For availability please contact sales dept.



Dostupni dok se ne rasprodaju zalihe  
Available until stock out



Proizvod za pravougaone kutije britanskog standarda  
Product for British standard rectangular box



Proizvod za izvoz  
For Export only

## Izmenljive folije sa simbolima

### Interchangeable films for signalings

		Opis	Description	Info	€
		<b>PEL01</b>	<b>PEL01</b> Komplet od 4 folije sa simbolom EXIT - 2 folije CRVENE boje i 2 folije ZELENE boje <i>Set of 4 films with EXIT symbol - n° 2 RED and n° 2 GREEN films</i>	1	1
		<b>PEL03</b>	<b>PEL02</b> Komplet od 4 folije sa simbolom ALARM - CRVENE boje <i>Set of 4 films with ALARM symbol - RED colour</i>	1	1
		<b>PEL05</b>	<b>PEL03</b> Komplet od 4 folije sa simbolom RESTORAN - CRNE boje <i>Set of 4 films with RESTAURANT symbol - BLACK colour</i>	1	1
		<b>PEL07</b>	<b>PEL04</b> Komplet od 4 folije sa simbolom WC - CRNE boje <i>Set of 4 films with WC symbol - BLACK colour</i>	1	1
		<b>PEL09</b>	<b>PEL05</b> Komplet od 4 folije sa simbolom STRELICE NA GORE - 2 folije CRVENE boje i 2 folije ZELENE boje <i>Set of 4 films with UP ARROW symbol - n° 2 RED and n° 2 GREEN films</i>	1	1
		<b>PEL11</b>	<b>PEL06</b> Komplet od 4 folije sa simbolom STRELICE - 2 folije CRVENE boje i 2 folije ZELENE boje <i>Set of 4 films with ARROW symbol - n° 2 RED and n° 2 GREEN films</i>	1	1
		<b>PEL13</b>	<b>PEL07</b> Komplet od 4 folije sa simbolom ZABRANJENO PUSENJE - CRVENE boje <i>Set of 4 films with NO SMOKING symbol - RED colour</i>	1	1
		<b>PEL14</b>	<b>PEL08</b> Komplet od 4 folije sa simbolom PROTIVPOZARNI APARAT - CRVENE boje <i>Set of 4 films with FIRE EXTINGUISHER symbol - RED colour</i>	1	1
		<b>PEL13</b>	<b>PEL09</b> Komplet od 4 folije sa simbolom INFORMACIJE - CRNE boje <i>Set of 4 films with INFORMATION symbol - BLACK colour</i>	1	1
		<b>PEL14</b>	<b>PEL10</b> Komplet od 4 folije sa simbolom KONFERENCIJSKA SALA - CRNE boje <i>Set of 4 films with CONFERENCE ROOM symbol - BLACK colour</i>	1	1
		<b>PEL13</b>	<b>PEL11</b> Komplet od 4 folije BELE/PROVIDNE za osvetljenje na stepenicama <i>Set of 4 WHITE/TRASPARENT films for stair riser light operating mode</i>	1	1
		<b>PEL14</b>	<b>PEL12</b> Komplet od 4 folije CRVENE boje za osvetljenje na stepenicama/svetlo dobrodošlice <i>Set of 4 RED films for stair riser light/courtesy light operating mode</i>	1	1
		<b>PEL13</b>	<b>PEL13</b> Komplet od 4 folije PLAVE boje za osvetljenje na stepenicama/svetlo dobrodošlice <i>Set of 4 BLUE films for stair riser light/courtesy light operating mode</i>	1	1
		<b>PEL14</b>	<b>PEL14</b> Komplet od 4 folije ZELENE boje za osvetljenje na stepenicama/svetlo dobrodošlice <i>Set of 4 GREEN films for stair riser light/courtesy light operating mode</i>	1	1

**Napomena:** ✓ folije se isporučuju u bojama koje su u skladu sa odredbom zakona 493 od 14/08/1996 - UNI 7543 - CEE 92/58 - BS-DIN-NF - ISO

✓ koristi se sa svetlosnom signalizacijom/svetiljkom 442TC76  
**Note:** ✓ the films will be supplied with colours in compliance with D.Lgs 493 dtd 14/08/1996 - UNI 7543 - CEE 92/58 - BS-DIN-NF-ISO  
 ✓ to be coupled with light signal/lighting 442TC76







# AVE Touch rešenja

AVE Touch Solutions



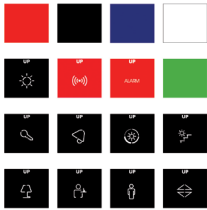

## Izmenljivi simboli za personalizaciju Interchangeable labels for customization

30

Opis	Description	Info	€
 <p><b>ETI16</b></p>	<p><b>ETI16</b> Komplet od 16 izmenljivih simbola za personalizaciju "skrivenih" komandi - različiti natpisi i simboli - CRNE boje - predlaže se upotreba sa maskama sjajnocrne boje (NAL) <i>16 interchangeable labels for "hidden" device customization - different writings and symbols - BLACK colour - it is recommended to be used with absolute black (NAL) front plates</i></p>	1	1
 <p><b>ETI16B</b></p>	<p><b>ETI16B</b> Komplet od 16 izmenljivih simbola za personalizaciju "skrivenih" komandi - različiti natpisi i simboli - BELE boje - predlaže se upotreba sa maskama sjajnobele boje (BL) i vodenozelene boje (VO) <i>Set of 16 interchangeable labels for "hidden" device customization - different writings and symbols - WHITE colour - it is recommended to be used with clear white (BL) and water green (VO)</i></p>	1	1
 <p><b>ETI16GR</b></p>	<p><b>ETI16GR</b> Komplet od 16 izmenljivih simbola za personalizaciju "skrivenih" komandi - različiti natpisi i simboli - SIVE boje - predlaže se upotreba sa maskama sjajnocrvene boje (RPL), vodenozelene (VO) i srebrnosive mat boje (GO) <i>Set of 16 interchangeable labels for "hidden" device customization - different writings and symbols - GREY colour - it is recommended to be used with Pompeian red (RPL), water green (VO) and silver grey (GO) front plates</i></p>	1	1

## Slepi modul - "skrivena" instalacija Blank insert - "hidden" installation

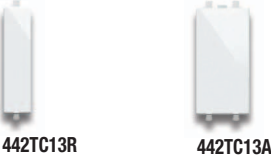
PATENTNI AVE N° 208 i N° 211  
AVE PATENTS N° 208 AND N° 211

Opis	Description	Info	€
 <p><b>442TC13R</b></p>	<p><b>442TC13R</b> Slepi modul za maske "Ave touch" - koristi se sa maskama "Ave Touch" - 1/2 modula <i>Blank insert - to be coupled with "Ave Touch" front plates - 1/2 module</i></p>	12	72
 <p><b>442TC13A</b></p>	<p><b>442TC13A</b> Slepi modul za maske "Ave touch" - može se postaviti na praznu kutiju - koristi se sa maskama "Ave Touch" - 1 modul <i>Equippable blank insert - preset for clipping it to empty box - to be coupled with "Ave Touch" front plates - 1 module</i></p>	10	60
<p><b>442TC13A/3</b></p>	<p><b>442TC13A/3</b> Slepi modul za maske "Ave touch" - isporučuje se sa praznom kutijom - koristi se sa "Ave Touch" - 3 modula <i>Equippable blank insert - supplied with empty box - to be coupled with "Ave Touch" front plates - 3 modules</i></p>	10	10

**Napomena:** Na zahtev, može biti isporučena kutija za 1 modul za kačenje slepog modula 442TC13A  
**Note:** the 1 module box for the 442TC13A blank insert clipping can be supplied upon request

## Primer instalacije Installation Examples

"Skrivene" komande sa simbolima za personalizaciju "Hidden" controls with customization labels

**2503MG**  
Ugradna kutija  
Flush mounted  
boxes

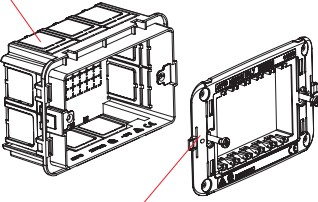

**ETI16**  
**ETI16B**  
**ETI16GR**  
Izmenljivi simboli za  
personalizaciju  
Interchangeable label for  
customization

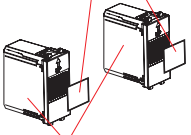

"Skrivene" komande  
"Hidden" controls

**44PVT0.../P**  
Maska "Ave Touch" za  
"skrivena" komande sa  
prozorima za simbole za  
personalizaciju  
"Ave Touch" front plate for  
"hidden" controls with windows  
for customization label

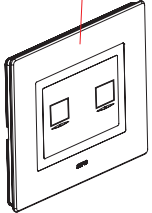

**44A03**  
Standardna armatura S44  
S44 standard frame

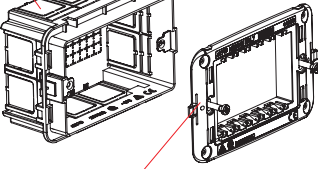

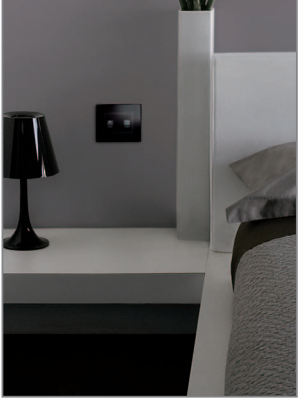



Za raspoloživost kontaktirajte  
Ave distributere  
For availability please contact  
sales dept.





Dostupni dok se ne  
rasprodaju zalihe  
Available until stock out



Proizvod za pravougaone  
kutije britanskog standarda  
Product for British standard  
rectangular box



Proizvod za  
izvoz  
For Export  
only

Opis	Description	Info	€
	<b>44ATC03ALS</b> Armatura za 3 modula za klizne maske "Ave Touch" - isporučuje se sa LED pozadinskim osvetljenjem 230V~ - boja prirodnog aluminijum - za kutije 2503MG, 253CG, 253GB - sa šrafovim <i>3 modules frame for "Ave Touch" sliding front plates - supplied with led indicator 230V~ power supply - natural aluminium colour - for 2503 MG, 253CG and 253GB boxes - with screws</i>	1	1
<b>44ATC03ALS</b>			
	<b>44ATC03B</b> Armatura za 3 modula za klizne maske "Ave Touch" - isporučuje se sa LED pozadinskim osvetljenjem 230V~ - RAL 9010 bele boje - za kutije 2503MG, 253CG, 253GB - sa šrafovim <i>3 modules frame for "Ave Touch" sliding front plates - supplied with led indicator 230V~ power supply - RAL 9010 white colour - for 2503MG, 253CG and 253GB boxes - with screws</i>	1	1
<b>44ATC03B</b>			
	<b>44ATC03GSL</b> Armatura za 3 modula za klizne maske "Ave Touch" - isporučuje se sa LED pozadinskim osvetljenjem 230V~ - sjajne tamnosive boje - za kutije 2503MG, 253CG, 253GB - sa šrafovim <i>3 modules frame for "Ave Touch" sliding front plates - supplied with led indicator 230V~ power supply - dark grey colour - for 2503MG, 253CG and 253GB boxes - with screws</i>	1	1
<b>44ATC03GSL</b>			

Primer instalacije

Installation Examples

Klizna maska

Sliding front plates

**2503MG**  
Ugradna kutija  
Flush mounted box

Moduli iz Sistema 44  
System 44 standard devices

**44ATC03ALS**  
**44ATC03B**  
**44ATC03GSL**

Specijalna armatura za klizne maske "Ave Touch"  
Special frame for "Ave Touch" sliding front plates

**44PATCS3...**  
**44PVTCS3...**  
Klizna maska "Ave Touch" sa simbolom "utičnice"  
"Ave Touch" sliding front plate with "plug" symbol

LED za pozadinsko osvetljenje, isporučuje se sa armaturom  
Led supplied with the frame

Kapice za šrafove (treba ih ukloniti)  
Screw cover (to be removed)

- 1** - Montirajte module u armaturu i ukoliko želite povežite led sa mrežnim napajanjem

- Uklonite kapice za šrafove

- Clip the devices at the frame and in case, supply the led indicator with power line voltage  
- Remove screw cover caps



- 2** Zašrafite specijalnu armaturu za kutiju bez preteranog pritezanja šrafova

Screw the special frame into the box **without over-tightening the screws**



- 3** Postavite kapice za šrafove u odgovarajuća ležišta uklanjajući višak plastike sa oboda kapica

Place the screw cover caps in the proper seat **after removing, if any, the residual of plastic on the edge.**



- 4** Pomoću šrafčigera uklonite plastičnu zaštitu

Remove the plastic protection using a screwdriver



- 5** Postavite kliznu masku u odgovarajuće vodice

Insert the sliding front plate in the proper guides



UKLANJANJE MASKE  
FRONT PLATE REMOVAL





# AVE Touch rešenja

## AVE Touch Solutions



### Specijalne kutije za brzu instalaciju u ravni sa zidom Special boxes for rapid wall-lined installation

PATENTI AVE N° 209  
AVE PATENTS N° 209

32

Opis Description Info €



SFM3

**SFM3** 2 2

Kutija 3 modula za pune zidove - rastojanje između šrafova 83,5 mm - u kompletu sa kartonskom zaštitom od prodora maltera, libelom (prikačena na kutiju) i bojivim okvirom (koji naleže na zid) i sa armaturom 3 modula Sistema 44

3 module box for brickwork walls - screw fixing centre 83,5 mm - supplied with mortarproof cardboard, spirit level (attached to the box) and paintable frame (lean against the wall) and "System 44" 3 module frame

**SFM3CG** 2 2

Kutija 3 modula za gips/kartonske zidove - rastojanje između šrafova 83,5 mm - u kompletu sa kartonskim šablonom, libelom (prikačena na kutiju) i bojivim okvirom (koji naleže na zid) i sa armaturom 3 modula Sistema 44

3 module box for hollow walls - screw fixing centre 83,5 mm - supplied with template, spirit level and paintable frame (lean against the wall) and "System 44" 3 module frame

**CRFM3GSL** 2 10

Rezervni ram - sjajnocrna boja (Life 44) - 3 modula

Spare inner frame - polished dark grey colour (Life 44) - 3 modules

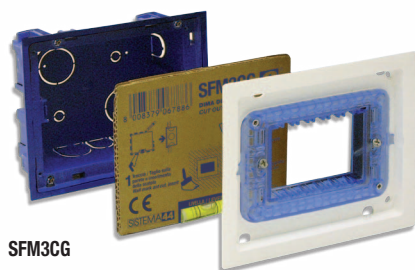

SFM3CG

**Napomena:** kutija sa maskom "Ave Touch" garantuje stepen zaštite IP44

**Note:** the box with the "Ave Touch" front plate guarantees an IP44 protection degree



CRFM3GSL

#### Veličina kutija SFM3 i SFM3CG

#### SFM3 and SFM3CG overall dimensions

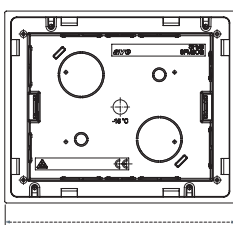

132 mm

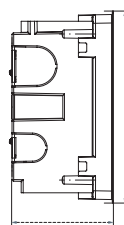

62 mm

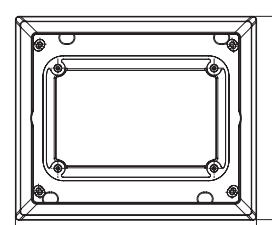

142 mm

120 mm

#### Instalacija u ravni sa zidom Wall-lined installations

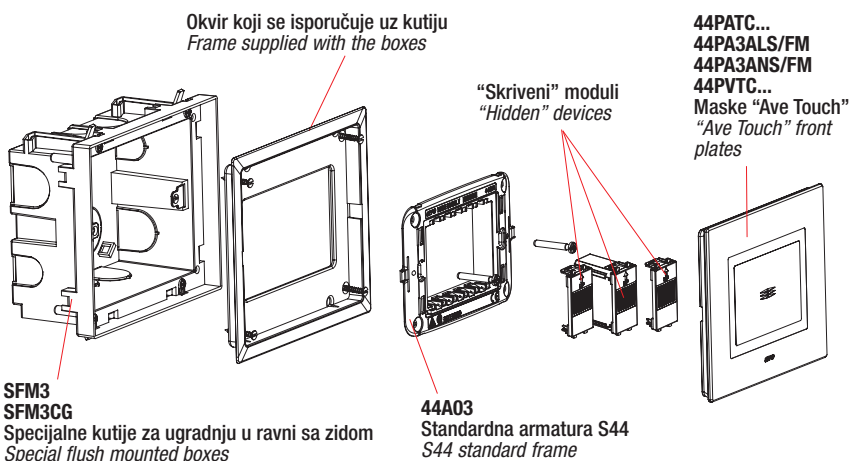

Za raspoloživost kontaktirajte Ave distributere  
For availability please contact sales dept.



Dostupni dok se ne rasprodaju zalihe  
Available until stock out



Proizvod za pravougaone kutije britanskog standarda  
Product for British standard rectangular box



Proizvod za izvoz  
For Export only

## SFM3 Kutija za klasične (pune) zidove

### SFM3 Box for brickwork walls

## SFM3CG Kutija za gips/kartonske zidove

### SFM3CG Box for hollow walls

Instalacija u ravni sa zidom *Wall-lined installations*

33



- 1 Napravite otvor u zidu i pomoću maltera pričvrstite kutiju u horizontalnom položaju, koristeći za nivelisanje priloženu libelu
- Make the hole and use the supplied level to fix the box*



- 2 Nanesite malter (ne postavljajte unutrašnji okvir)
- Apply the mortar (do not install the inner frame)*



- 3 Poravnajte završni sloj maltera (ne postavljajte unutrašnji okvir)
- Make the finishing touches (do not install the inner frame)*

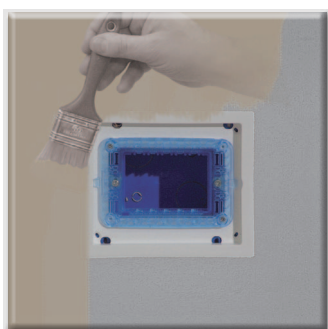

- 4 Postavite okvir na kutiju, i nakon toga obojite zid zajedno sa okvirom
- Install the inner frame, and after, paint the wall and the inner frame*



- 5 Postavite masku
- Konačan rezultat je "vidljivi okvir"
- Place the finishing front plate*
- Final effect "visible adapter frame"*



- 1 Pomoću libele nivelirate, pa iscrtajte šablon po zidu
- Use the level to fix the template then trace the line*

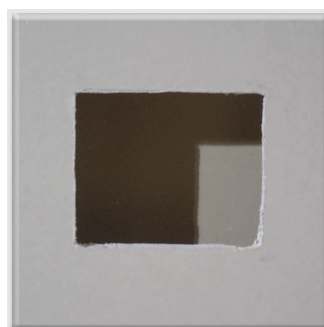

- 2 Napravite otvor
- Make the hole*



- 3 Postavite kutiju, pričvrstite je na zid i nakon toga poravnajte zid (ne postavljajte unutrašnji okvir)
- After installing the box, smooth the wall (do not install the inner frame)*

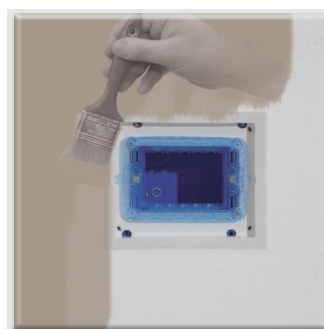

- 4 Pričvrstite okvir na kutiju, i nakon toga obojite zid zajedno sa okvirom
- Install the inner frame, and after, paint the wall and the inner frame*



- 5 Postavite masku
- Konačan rezultat je "vidljivi okvir"
- Place the finishing front plate*
- Final effect "visible adapter frame"*



Sistema 45



# AVE Touch rešenja

AVE Touch Solutions



Specijalne kutije za preciznu instalaciju u potpunoj ravni sa zidom  
Special boxes for high precision completely wall-lined installation

34

Opis

Description

Info

€

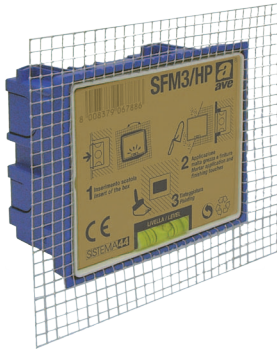

SFM3/HP

### SFM3/HP

Kutija 3 modula za pune zidove - rastojanje između šrafova 83,5 mm - u kompletu sa kartonskom zaštitom od prodora maltera i libelom (prikačena na kutiju) i sa armaturom 3 modula Sistema 44

3 modules box for brickworks walls - screw fixing centre 83,5 mm - supplied with cardboard mortarproof, spirit level (attached to the box) and System 44 3 module frame

1 1

### SFM3CG/HP

Kutija 3 modula za gips/kartonske zidove - rastojanje između šrafova 83,5 mm - u kompletu sa kartonskim šablonom, libelom i armaturom 3 modula Sistema 44

3 modules box for hollow walls - screw fixing centre 83,5 mm - supplied with template, spirit level and System 44 3 module frame

1 1

**Napomena:** kutija sa maskom "Ave Touch" garantuje stepen zaštite IP44

**Note:** the box with the "Ave Touch" front plate guarantees an IP44 protection degree

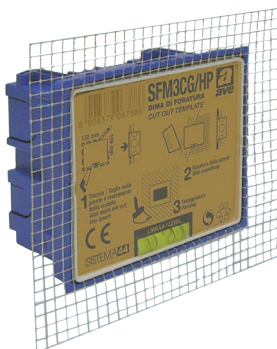

SFM3CG/HP

Veličina kutija

Overall dimensions

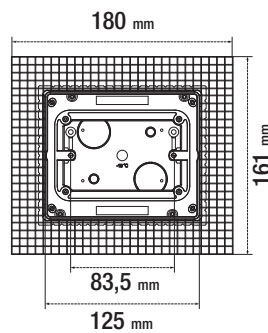

SFM3/HP

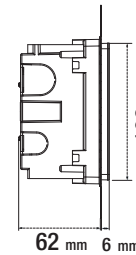

SFM3CG/HP

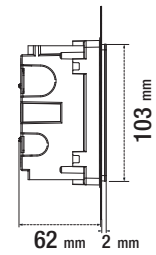

Ave Touch u ravni sa zidom Wall-lined Ave Touch

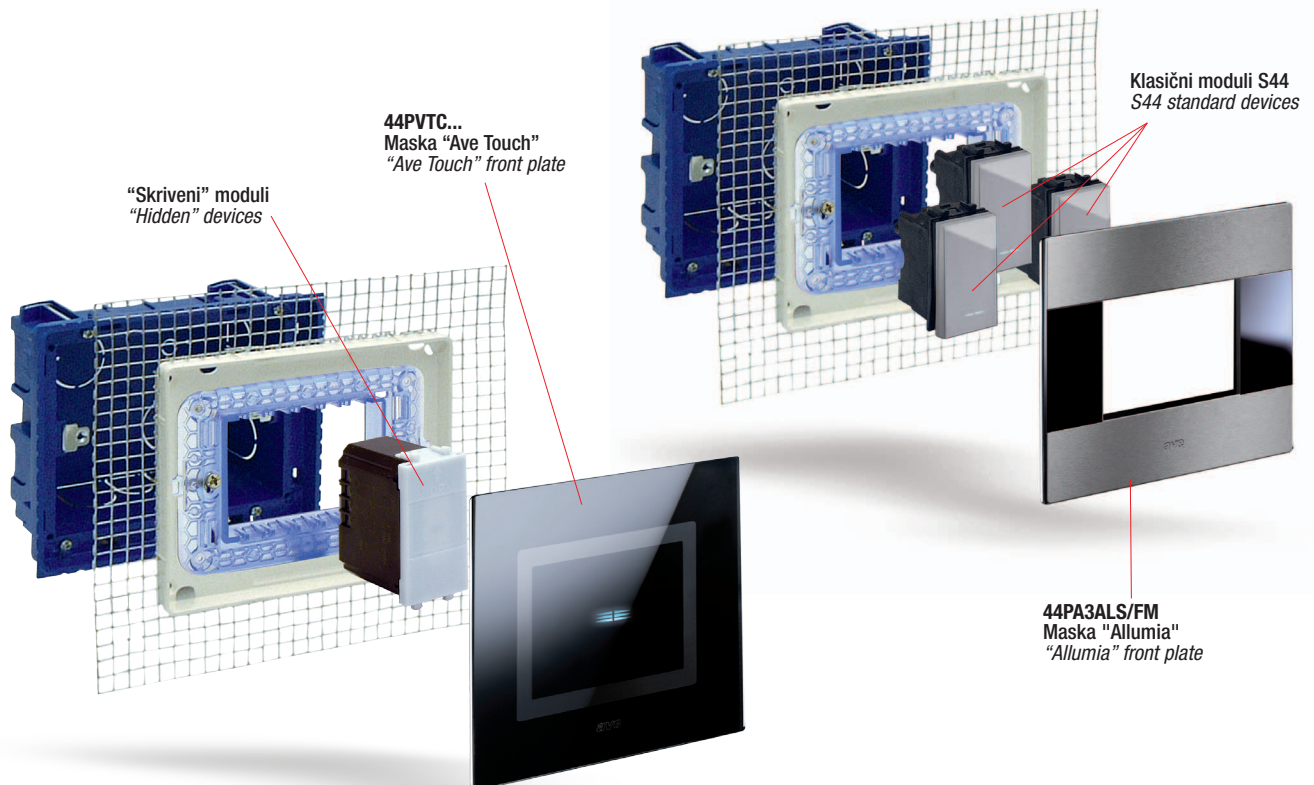

Za raspoloživost kontaktirajte Ave distributere  
For availability please contact sales dept.



Dostupni dok se ne rasprodaju zalihe  
Available until stock out



Proizvod za pravougaone kutije britanskog standarda  
Product for British standard rectangular box



Proizvod za izvoz  
For Export only

Instalacija u ravni sa zidom *Wall-lined installations*



**1** Napravite otvor u zidu i pomoću maltera pričvrstite kutiju u horizontalnom položaju, koristeći za nivelisanje priloženu libelu  
*Make the hole and use the supplied level to fix the box*



**1** Pomoću libele nivelišite, pa iscrtajte šablon po zidu  
*Use the level to fix the template then trace the line*



**2** Nanesite malter  
*Apply the mortar*

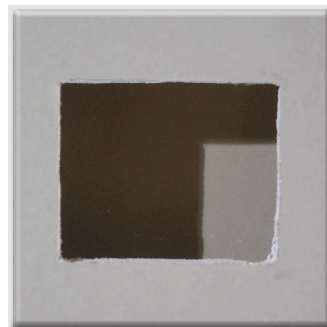

**2** Napravite otvor  
*Make the hole*



**3** Poravnajte završni sloj maltera  
*Make the finishing touches*

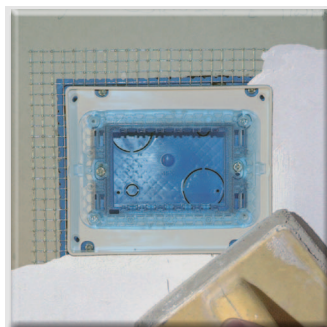

**3** Postavite kutiju, pričvrstite je na zid i nakon toga poravnajte zid  
*After installing the box, smooth the wall*

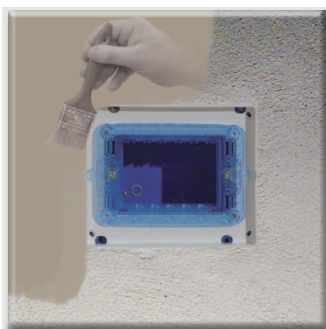

**4** Obojite zid  
*Paint the wall*

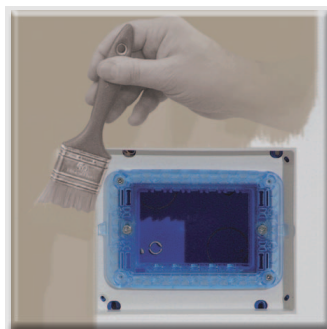

**4** Obojite zid  
*Paint the wall*



**5** Postavite masku  
Konačan rezultat je "maska u ravni sa zidom bez okvira"  
*Place the finishing front plate  
Final effect "wall-lined without adapter frame"*



**5** Postavite masku  
Konačan rezultat je "maska u ravni sa zidom bez okvira"  
*Place the finishing front plate  
Final effect "wall-lined without adapter frame"*



# AVE Touch rešenja

AVE Touch Solutions



“Ave Touch” maske od aluminijuma za okruglu ili kvadratnu kutiju  
“Ave Touch” aluminium front plates for round or square box

36



ALS



ANS

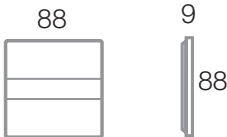

Opis Description Info €

Do 2 “skrivene” komande  
Up to 2 “hidden” controls

■ 44PATC22ALS 1 1  
Brušeni aluminijum  
Natural brushed aluminium

■ 44PATC22ANS 1 1  
Tamni brušeni aluminijum  
Anthracite brushed aluminium

**Napomena:** proverite da li maska savršeno prijanja na “skrivenu” komandu  
**Note:** make sure that the front plate sticks perfectly to the “hidden” control devices

Korisiti se sa armaturom  
To be used with

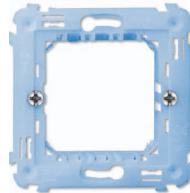

44A02  
44A02SG  
44A02VT

Rezervni umetak Spare inner lenses Opis Description Info €



VTR21GSL 2 50  
Izmenljivi umetak za 1 komandu “na dodir”  
- 1 simbol za indentifikaciju pozicije komande  
- sjajne tamnosive boje  
Interchangeable lens for 1 “touch” control  
- no. 1 mark for control point identification  
- polished dark grey

VTR22GSL 2 50  
Izmenljivi umetak za 2 komande “na dodir”  
- 2 simbola za indentifikaciju pozicije komande  
- sjajne tamnosive boje  
Interchangeable lens for 2 “touch” controls  
- no. 2 marks for control point identification  
- polished dark grey

Spoljašnji okvir Finishing ring Opis Description Info €

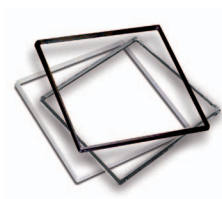

44RNG22B 2 50  
Ral 9010 bela  
RAL 9010 white

44RNG22N 2 50  
Sjajna tamnosiva  
Polished dark grey



Za raspoloživost kontaktirajte  
Ave distributere  
For availability please contact  
sales dept.



Dostupni dok se ne  
rasprodaju zalihe  
Available until stock out







Proizvod za pravougaone  
kutije britanskog standarda  
Product for British standard  
rectangular box

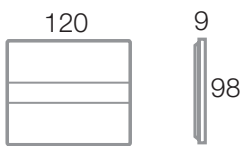

Proizvod za  
izvoz  
For Export  
only

**“Ave Touch” maske od aluminijuma za kutiju 3 modula (rastojanje između šrafova 83,5 mm)**  
**“Ave Touch” aluminium front plates for 3 modules box (fixing centres 83,5 mm)**

	Opis	Description	Info	€
 <b>ALS</b>	<b>Do 3 “skrivene” komande</b>	<b>Up to 3 “hidden” controls</b>		
	<b>■ 44PATC3ALS</b> Brušeni aluminijum <i>Natural brushed aluminium</i>			1
 <b>ANS</b>	<b>■ 44PATC3ANS</b> Tamni brušeni aluminijum <i>Anthracite brushed aluminium</i>		1	1
	<b>Napomena: proverite da li maska savršeno prijanja na “skrivenu” komandu</b> <b>Note: make sure that the front plate sticks perfectly to the “hidden” control devices</b>			
	<b>Koristi se sa armaturom</b> <b>To be used with</b>			
	 <b>44A03</b>			

37

Sistema 45

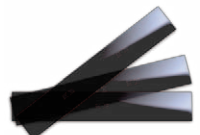
Rezervni umetak	Spare inner lenses	Opis	Description	Info	€
		<b>VTR01GSL</b>	Izmenljivi umetak za 1 komandu “na dodir” - 1 simbol za identifikaciju pozicije komande - sjajne tamnosive boje <i>Interchangeable lens for 1 “touch” control</i> - no. 1 mark for control point identification - polished dark grey	2	50
		<b>VTR02GSL</b>	Izmenljivi umetak za 2 komande “na dodir” - 2 simbola za identifikaciju pozicije komande - sjajne tamnosive boje <i>Interchangeable lens for 2 “touch” controls</i> - no. 2 marks for control point identification - polished dark grey	2	50
		<b>VTR3GSL</b>	Izmenljivi umetak za 3 komande “na dodir” - 3 simbola za identifikaciju pozicije komande - sjajno tamnosive boje <i>Interchangeable lens for 3 “touch” controls</i> - no.3 marks for control point identification - polished dark grey	2	50

Spoljašnji okvir	Finishing ring	Opis	Description	Info	€
		<b>44RNG3B</b>	Ral 9010 bela <i>RAL 9010 white</i>	2	50
		<b>44RNG3N</b>	Sjajna tamnosiva <i>Polished dark grey</i>	2	50





# AVE Touch rešenja

AVE Touch Solutions



“Ave Touch” maske od aluminijuma za kutiju 4 modula (rastojanje između šrafova 108,5 mm)  
“Ave Touch” aluminium front plates for 4 modules box (fixing centres 108,5 mm)

38



ALS



ANS

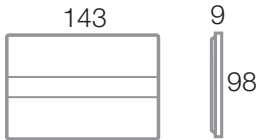

Opis Description Info €

Do 4 “skrivena” komande  
Up to 4 “hidden” controls

■ 44PATC4ALS 1 1  
Brušeni aluminijum  
Natural brushed aluminium

■ 44PATC4ANS 1 1  
Tamni brušeni aluminijum  
Anthracite brushed aluminium

**Napomena:** proverite da li maska savršeno prijanja na “skrivenu” komandu  
**Note:** make sure that the front plate sticks perfectly to the “hidden” control devices

Koristi se sa armaturom  
To be used with

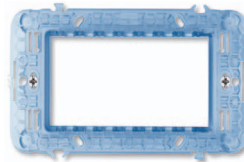

44A04

## Rezervni umetak Spare inner lenses

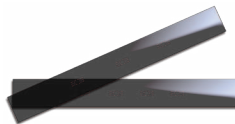

VTR03GSL 2 50  
Izmenjivi umetak za 3 komande “na dodir”  
- 3 simbola za identifikaciju pozicije komande  
- sjajne tamnosive boje  
Interchangeable lens for 3 “touch” controls  
- no. 3 marks for control point identification  
- polished dark grey

VTR4GSL 2 50  
Izmenjivi umetak za 4 komande “na dodir”  
- 4 simbola za identifikaciju pozicije komande  
- sjajne tamnosive boje  
Interchangeable lens for 4 “touch” controls  
- no. 4 marks for control point identification  
- polished dark grey

## Spoljašnji okvir Finishing ring

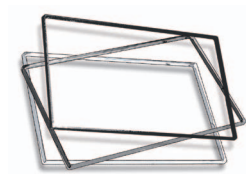

Opis Description Info €

44RNG4B 2 50  
Ral 9010 bela  
RAL 9010 white

44RNG4N 2 50  
Sjajna tamnosiva  
Polished dark grey



Za raspoloživost kontaktirajte Ave distributere  
For availability please contact sales dept.



Dostupni dok se ne rasprodaju zalihe  
Available until stock out







Proizvod za pravougaone kutije britanskog standarda  
Product for British standard rectangular box

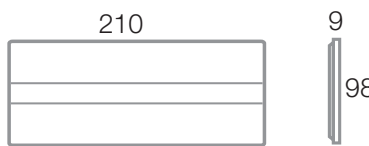

Proizvod za izvoz  
For Export only

“Ave Touch” maske od aluminijuma za kutiju 6-7 modula (rastojanje između šrafova 158,5 mm)  
 “Ave Touch” aluminium front plates for 6-7 modules box (fixing centres 158,5 mm)

	Opis	Description	Info	€
 <b>ALS</b>	<b>Do 7 “skrivenih” komadni</b> Up to 7 "hidden" controls			
	■ <b>44PATC7ALS</b> Brušeni aluminijum Natural brushed aluminium		1	1
 <b>ANS</b>	■ <b>44PATC7ANS</b> Tamni brušeni aluminijum Anthracite brushed aluminium			1 1
	<b>Napomena:</b> proverite da li maska savršeno prijanja na “skrivenu” komandu <b>Note:</b> make sure that the front plate sticks perfectly to the “hidden” control devices			
	<b>Koristi se sa armaturom</b> To be used with			
	 <b>44A07</b>			



Sistema 45

Rezervni umetak	Spare inner lenses	Opis	Description	Info	€
	<b>VTR04GSL</b> Izmenljivi umetak za 4 komande “na dodir” - 4 simbola za identifikaciju pozicije komande - sjajne tamnosive boje Interchangeable lens for 4 “touch” controls - no. 4 marks for control point identification - polished dark grey			2	50
	<b>VTR7GSL</b> Izmenljivi umetak za 7 komandi na “dodir” - 7 simbola za identifikaciju pozicije komande - sjajne tamnosive boje Interchangeable lens for 7 “touch” controls - no. 7 marks for control point identification - polished dark grey			2	50



# AVE Touch rešenja

AVE Touch Solutions



“Ave Touch” maske od aluminijuma za kutiju 3 modula (rastojanje između šrafova 83,5 mm)

“Ave Touch” aluminium front plates for 3 modules box (fixing centres 83,5 mm)

40



ALS



ANS



Opis	Description	Info	€
------	-------------	------	---

Do 6 (3+3) “skrivenih” komandi  
Up to 6 (3+3) "hidden" controls

■ 44PATC16ALS	Brušeni aluminijum Natural brushed aluminium	<b>Novo</b>	1 1
■ 44PATC16ANS	Tamni brušeni aluminijum Anthracite brushed aluminium	<b>Novo</b>	1 1

**Napomene:** proverite da li maska savršeno prijanja na “skrivenu” komandu  
upotrebljava se sa MultiTouch modulom 442TC16

**Note:** make sure that the front plate sticks perfectly to the "hidden" control devices

Koristi se sa armaturom  
To be used with

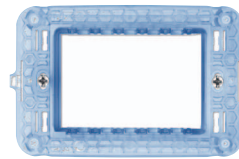

44A03

## Spoljašnji okvir Finishing ring

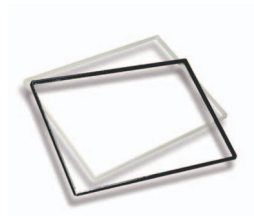

Opis	Description	Info	€
------	-------------	------	---

44RNG3B	Ral 9010 bela RAL 9010 white	2	50
44RNG3N	Sjajna tamnosiva Polished dark grey	2	50



Za raspoloživost kontaktirajte  
Ave distributere  
For availability please contact  
sales dept.



Dostupni dok se ne  
rasprodaju zalihe  
Available until stock out





Proizvod za pravougaone  
kutije britanskog standarda  
Product for British standard  
rectangular box



Proizvod za  
izvoz  
For Export  
only

**“Ave Touch” maske od aluminijuma za kutiju 3 modula (rastojanje između šrafova 83,5 mm)**  
**“Ave Touch” aluminium front plates for 3 modules box (fixing centres 83,5 mm)**

	Opis	Description	Info	€
 <b>ALS</b>	<b>Za 1 “skriveni” taster sa prozorčićem za karticu sa imenom</b> <b>For 1 “hidden” push-button module with name tag</b>			
	<b>■ 44PATC88ALS</b> Brušeni aluminijuma <i>Natural brushed aluminium</i>			1
 <b>ANS</b>	<b>Napomene: proverite da li maska savršeno prijanja na “skrivenu” komandu</b> <b>upotrebljava se sa AveTouch tasterom za zonu 442TC88</b>			
	<b>■ 44PATC88ANS</b> Tamni brušeni aluminijum <i>Anthracite brushed aluminium</i>			1

**Note: make sure that the front plate sticks perfectly to the “hidden” control devices**



**Koristi se sa armaturom**  
**To be used with**

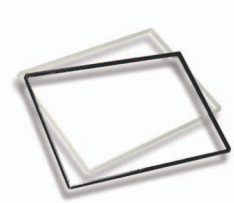

**44A03**

	Opis	Description	Info	€	
	<b>Spoljašnji okvir Finishing ring</b>				
	<b>44RNG3B</b> Ral 9010 bela <i>RAL 9010 white</i>			2	50
	<b>44RNG3N</b> Sjajna tamnosiva <i>Polished dark grey</i>			2	50



# AVE Touch rešenja

AVE Touch Solutions



“Ave Touch” maske od aluminijuma za kutiju 3 modula (rastojanje između šrafova 83,5 mm)

“Ave Touch” aluminium front plates for 3 modules box (fixing centres 83,5 mm)

42



ALS



ANS

Opis Description Info €

Za 1 “skriveni” modul svetlosne signalizacije/svetiljke  
For 1 “hidden” light/lighting signal module

■ 44PATC76ALS 1 1  
Brušeni aluminijum  
Natural brushed aluminium

■ 44PATC76ANS 1 1  
Tamni brušeni aluminijum  
Anthracite brushed aluminium

**Napomene:** za izmenljive folije vidi str. 29  
upotrebljava se sa svetlosnom signalizacijom 442TC76

**Note:** for interchangeable films see pag. 29

Koristi se sa armaturom  
To be used with

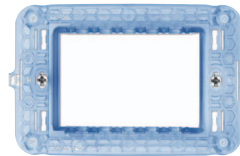
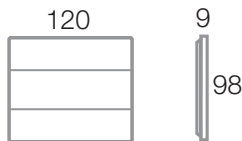

44A03

## Spoljašnji okvir Finishing ring

Opis Description Info €

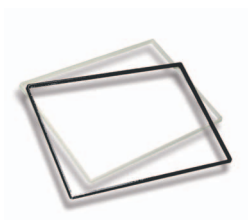

44RNG3B 2 50  
Ral 9010 bela  
RAL 9010 white

44RNG3N 2 50  
Sjajna tamnosiva  
Polished dark grey



Za raspoloživost kontaktirajte  
Ave distributere  
For availability please contact  
sales dept.



Dostupni dok se ne  
rasprodaju zalihe  
Available until stock out



Proizvod za pravougaone  
kutije britanskog standarda  
Product for British standard  
rectangular box



Proizvod za  
izvoz  
For Export  
only

**“Ave Touch” maske od aluminijuma za kutiju 3 modula (rastojanje između šrafova 83,5 mm)**  
**“Ave Touch” aluminium front plates for 3 modules box (fixing centres 83,5 mm)**



ALS



ANS

Descrizione *Description*

Info

€

**Klizna maska 3 modula Sistem 44 - sa simbolon “utičnice”**  
*Sliding for covering 3 mod. S44 - “plug” symbol*

■ 44PATCS3ALS	1	1
Brušeni aluminijum <i>Natural brushed aluminium</i>		
■ 44PATCS3ANS	1	1
Tamni brušeni aluminijum <i>Anthracite brushed aluminium</i>		

**Napomena:** ✓ koristi se samo sa specijalnim armaturama 44ATC03ALS ili 44ATC03GSL  
 ✓ svetleći simbol utičnice sa led lampicom koja se isporučuje s armaturom  
 ✓ koristi se sa svim uređajima 1, 2 ili 3 modula Sistema 44 izuzev sa proizvodima na 66. strani

**Note:** ✓ to be used only with special frame 44ATC03ALS or 44ATC03GSL  
 ✓ “plug” symbol lightable by led supplied with the frame  
 ✓ it can be used with all the system 44 standard products 1-2 or 3 modules except for the codes on page 66

**Koristi se sa armaturom**  
**To be used with**

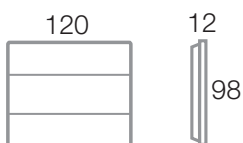

44ATC03ALS



44ATC03GSL

Primer upotrebe *Application example*



Mln. pakovanje kom.  
 Min. Packaging pcs

Stand. pakovanje kom.  
 Std. Packaging pcs



# AVE Touch rešenja

AVE Touch Solutions



“Ave Touch” maske od aluminijuma za kutiju 3 modula (rastojanje između šrafova 83,5 mm)

“Ave Touch” aluminium front plates for 3 modules box (fixing centres 83,5 mm)

44



ALS



ANS

Opis	Description	Info	€
------	-------------	------	---

**Klizna maska 3 modula Sistem 44**  
*Sliding for covering 3 modules S44*

■ 44PATCN3ALS	Brušeni aluminijum <i>Natural brushed aluminium</i>	1	1
---------------	--	---	---

■ 44PATCN3ANS	Tamni brušeni aluminijum <i>Anthracite brushed aluminium</i>	1	1
---------------	---	---	---

**Napomena:** ✓ koristi se samo sa specijalnim armaturama 44ATC03ALS ili 44ATC03GSL  
 ✓ koristi se sa svim proizvodima 1, 2 ili 3 modula Sistema 44 izuzev sa proizvodima na 66. strani

**Note:** *to be used only with special frame 44ATC03ALS or 44ATC03GSL  
 it can be used with all the system 44 standard products 1-2 or 3 modules except for the codes on page 66*

**Koristi se sa armaturom**  
*To be used with*



44ATC03ALS



44ATC03GSL

Primer upotrebe *Application example*



Za raspoloživost kontaktirajte Ave distributere  
 For availability please contact sales dept.



Dostupni dok se ne rasprodaju zalihe  
 Available until stock out



Proizvod za pravougaone kutije britanskog standarda  
 Product for British standard rectangular box



Proizvod za izvoz  
 For Export only

**“Ave Touch” maske od aluminijuma za kutiju 3 modula (rastojanje između šrafova 83,5 mm)**  
**“Ave Touch” aluminium front plates for 3 modules box (fixing centres 83,5 mm)**

	Opis	Description	Info	€
 <b>ALS</b>		<b>Olakšana komanda za osobe sa posebnim potrebama - personalizujuća</b> <b>Easier control for disabled - customizable</b>		
	■ <b>44PATC3ALS/DA</b>	Brušeni aluminijum Natural brushed aluminium	1	1
	■ <b>44PATC3ANS/DA</b>	Tamni brušeni aluminijum Anthracite brushed aluminium	1	1



**ANS**

**Koristi se sa armaturama**  
**To be used with**

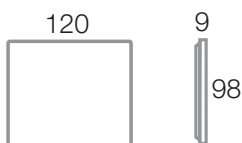

**44A03**

Spoljašnji okvir	Finishing ring	Opis	Description	Info	€
		<b>44RNG3B</b>	Ral 9010 bela RAL 9010 white	2	50
		<b>44RNG3N</b>	Sjajna tamnosiva Polished dark grey	2	50





# AVE Touch rešenja

AVE Touch Solutions



“Ave Touch” maske od aluminijuma za kutije 3 modula (rastojanje između šrafova 83,5 mm)

“Ave Touch” aluminium front plates for 3 modules box (fixing centres 83,5 mm)

46



ALS



ANS

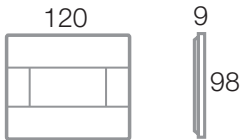

Opis Description Info €

**3 modula sistema S44 - i za instalaciju u "ravni sa zidom"**  
**3 modules standard for S44 - also for "wall-lined" installations**

■ **44PA3ALS/FM** 1 1  
Brušeni aluminijum  
Natural brushed aluminium

■ **44PA3ANS/FM** 1 1  
Tamni brušeni aluminijum  
Anthracite brushed aluminium

Koristi se sa armaturom  
To be used with



44A03

## Spoljašnji okvir Finishing ring

Opis Description Info €

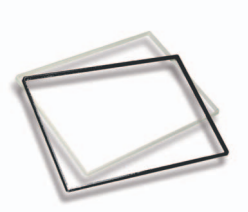

**44RNG3B** 2 50  
Ral 9010 bela  
RAL 9010 white

**44RNG3N** 2 50  
Sjajna tamnosiva  
Polished dark grey



Za raspoloživost kontaktirajte Ave distributere  
For availability please contact sales dept.



Dostupni dok se ne rasprodaju zalihe  
Available until stock out



Proizvod za pravougaone kutije britanskog standarda  
Product for British standard rectangular box



Proizvod za izvoz  
For Export only

**“Ave Touch” maske od aluminijuma za kutije 4 modula (rastojanje između šrafova 108,5 mm)**  
**“Ave Touch” aluminium front plates for 4 modules box (fixing centres 108,5 mm)**

	Opis	Description	Info	€
	<b>4 modula sistema S44</b> <b>4 modules standard for S44</b>			
	■ <b>44PA4ALS/FM</b>		<b>Novo</b>	1 1
	Brušeni aluminijum Natural brushed aluminium			
	■ <b>44PA4ANS/FM</b>		<b>Novo</b>	1 1
	Tamni brušeni aluminijum Anthracite brushed aluminium			



ALS



ANS

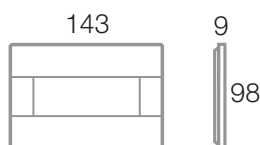

Koristi se sa armaturom  
To be used with



44A04

**“Ave Touch” maske od aluminijuma za kutije 6-7 modula (rastojanje između šrafova 158,5 mm)**  
**“Ave Touch” aluminium front plates for 6-7 modules box (fixing centres 158,5 mm)**

	Opis	Description	Info	€
	<b>7 modula sistema S44</b> <b>7 modules standard for S44</b>			
	■ <b>44PA7ALS/FM</b>		<b>New</b>	1 1
	Alluminio naturale spazzolato Natural brushed aluminium			
	■ <b>44PA7ANS/FM</b>		<b>New</b>	1 1
	Alluminio antracite spazzolato Anthracite brushed aluminium			



ALS



ANS

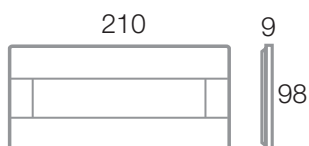

Koristi se sa armaturom  
To be used with



44A07

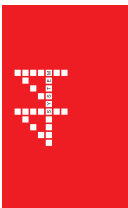



# AVE Touch rešenja

## AVE Touch Solutions



“Ave Touch” staklene maske za okruglu ili kvadratnu kutiju  
“Ave Touch” glass front plates for round or square box

48



BL



GO



NAL



RPL



VO

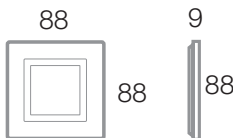

Opis Description Info €

Za 1 “skrivenu” komandu  
For 1 “hidden” control

□ 44PVTG21BL  
Sjajnobela  
Clear white 1 1

■ 44PVTG21GO  
Srebrnosiva mat  
Frosted silver grey 1 1

■ 44PVTG21NAL  
Sjajnocrna  
Clear absolute black 1 1

■ 44PVTG21RPL  
Sjajnocrvena  
Clear Pompeian red 1 1

■ 44PVTG21VO  
Vodenozelena  
Frosted water green 1 1

**Napomena:** ✓ isporučuju se sa 2 slepa modula 442TC13R  
✓ proverite da li maska savršeno prijanja na “skrivenu” komandu

**Note:** ✓ supplied with 2 blank inserts 442TC13R  
✓ make sure that the front plate sticks perfectly to the “hidden” control devices

Koristi se sa armaturom  
To be used with

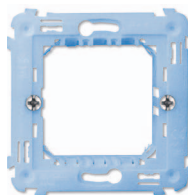

44A02  
44A02SG  
44A02VT

### Spoljašnji okvir Finishing ring

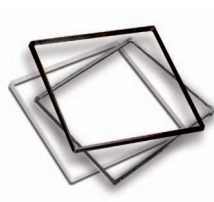

Opis Description Info €

44RNG22B  
Ral 9010 bela  
RAL 9010 white 2 50

44RNG22N  
Sjajna tamnosiva  
Polished dark grey 2 50



Za raspoloživost kontaktirajte  
Ave distributere  
For availability please contact  
sales dept.



Dostupni dok se ne  
rasprodaju zalihe  
Available until stock out







Proizvod za pravougaone  
kutije britanskog standarda  
Product for British standard  
rectangular box



Proizvod za  
izvoz  
For Export  
only

**“Ave Touch” staklene maske za okruglu ili kvadratnu kutiju**  
**“Ave Touch” glass front plates for round or square box**

		Opis	Description	Info	€
		<b>Za 2 “skrivené” komande</b> <i>For 2 "hidden" controls</i>			
<b>BL</b>	<b>GO</b>	<input type="checkbox"/>	<b>44PVTG22BL</b> Sjajnobela <i>Clear white</i>	1	1
		<input checked="" type="checkbox"/>	<b>44PVTG22GO</b> Srebrnosiva mat <i>Frosted silver grey</i>	1	1
		<input checked="" type="checkbox"/>	<b>44PVTG22NAL</b> Sjajnocrna <i>Clear absolute black</i>	1	1
<b>NAL</b>	<b>RPL</b>	<input checked="" type="checkbox"/>	<b>44PVTG22RPL</b> Sjajnocrvena <i>Clear Pompeian red</i>	1	1
		<input checked="" type="checkbox"/>	<b>44PVTG22VO</b> Vodnozelená <i>Frosted water green</i>	1	1



**VO**

**Napomena:** proverite da li maska savršeno prijanja na “skrivenú” komandu  
**Note:** make sure that the front plate sticks perfectly to the “hidden” control devices

**Koristi se sa armaturom**  
**To be used with**

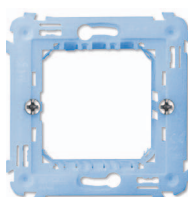

**44A02**  
**44A02SG**  
**44A02VT**

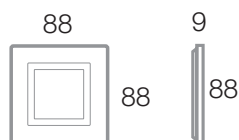

Sistema 45

<b>Spoljašnji okvir</b> <i>Finishing ring</i>		Opis	Description	Info	€
		<input type="checkbox"/>	<b>44RNG22B</b> Ral 9010 bela <i>RAL 9010 white</i>	2	50
		<input type="checkbox"/>	<b>44RNG22N</b> Sjajna tamnosiva <i>Polished dark grey</i>	2	50



# AVE Touch rešenja

AVE Touch Solutions



“Ave Touch” staklene maske za kutiju 3 modula (rastojanje između šrafova 83,5 mm)

“Ave Touch” glass front plates for rectangular 3 modules box (fixing centres 83,5 mm)

50



BL

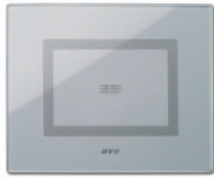

GO



NAL



RPL



VO



Opis Description Info €

Za 1 “skrivenu” komandu  
For 1 “hidden” control

□ 44PVTC01BL 1 1

Sjajnobela  
Clear white

■ 44PVTC01GO 1 1

Srebrnosiva mat  
Frosted silver grey

■ 44PVTC01NAL 1 1

Sjajnocrna  
Clear absolute black

■ 44PVTC01RPL 1 1

Sjajnocrvena  
Clear Pompeian red

■ 44PVTC01VO 1 1

Vodnozeleno  
Frosted water green

**Napomena:** ✓ isporučuju se sa 2 slepa modula 442TC13A  
✓ proverite da li maska savršeno prijanja na “skrivenu” komandu

**Note:** ✓ supplied with 2 blank inserts 442TC13A  
✓ make sure that the front plate sticks perfectly to the “hidden” control devices

Koristi se sa armaturom  
To be used with



44A03

## Spoljašnji okvir Finishing ring



Opis Description Info €

44RNG3B 2 50

Ral 9010 bela  
RAL 9010 white

44RNG3N 2 50

Sjajna tamnosiva  
Polished dark grey



Za raspoloživost kontaktirajte  
Ave distributere  
For availability please contact  
sales dept.



Dostupni dok se ne  
rasprodaju zalihe  
Available until stock out







Proizvod za pravougaone  
kutije britanskog standarda  
Product for British standard  
rectangular box



Proizvod za  
izvoz  
For Export  
only

**“Ave Touch” staklene maske za kutiju 3 modula (rastojanje između šrafova 83,5 mm)**  
**“Ave Touch” glass front plates for rectangular 3 modules box (fixing centres 83,5 mm)**

51

	Opis	Description	Info	€
	BL			
	GO			
	NAL			
	RPL			
	VO			

**Za 1 komandu - sa prozorčićem za simbol za personalizaciju**  
**For 1 control - window for customization labels**

<input type="checkbox"/>	44PVT01BL/P	Sjajnobela Clear white	1	1
<input type="checkbox"/>	44PVT01GO/P	Srebrnosiva mat Frosted silver grey	1	1
<input type="checkbox"/>	44PVT01NAL/P	Sjajnocrna Clear absolute black	1	1
<input type="checkbox"/>	44PVT01RPL/P	Sjajnocrvena Clear Pompeian red	1	1
<input type="checkbox"/>	44PVT01VO/P	Vodnozeleno Frosted water green	1	1

**Napomena:** ✓ isporučuju se sa 2 slepa modula 442TC13A  
 ✓ proverite da li maska savršeno prijanja na “skrivenu” komandu

**Note:** ✓ supplied with 2 blank inserts 442TC13A  
 ✓ make sure that the front plate sticks perfectly to the “hidden” control devices

**Koristi se sa armaturom**  
**To be used with**



44A03



Sistema 45

Spoljašnji okvir	Opis	Description	Info	€
	44RNG3B	Ral 9010 bela RAL 9010 white	2	50
	44RNG3N	Sjajna tamnosiva Polished dark grey	2	50



# AVE Touch rešenja

AVE Touch Solutions



“Ave Touch” staklene maske za kutiju 3 modula (rastojanje između šrafova 83,5 mm)  
“Ave Touch” glass front plates for rectangular 3 modules box (fixing centres 83,5 mm)

52

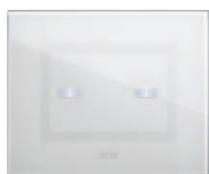

BL



GO



NAL



RPL



VO



Opis Description Info €

### Za 2 “skrivenne” komande For 2 “hidden” controls

□ 44PVTC02BL 1 1

Sjajnobela  
Clear white

■ 44PVTC02GO 1 1

Srebrnosiva mat  
Frosted silver grey

■ 44PVTC02NAL 1 1

Sjajnocrna  
Clear absolute black

■ 44PVTC02RPL 1 1

Sjajnocrvena  
Clear Pompeian red

■ 44PVTC02VO 1 1

Vodnozeleno  
Frosted water green

**Napomena:** ✓ isporučuje se sa 1 slepim modulom 442TC13A  
✓ proverite da li maska savršeno prijanja na “skrivenu” komandu

**Note:** ✓ supplied with 1 blank insert 442TC13A  
✓ make sure that the front plate sticks perfectly to the “hidden” control devices

Koristi se sa armaturom  
To be used with



44A03

### Spoljašnji okvir Finishing ring

Opis Description Info €



44RNG3B 2 50

Ral 9010 bela  
RAL 9010 white

44RNG3N 2 50

Sjajna tamnosiva  
Polished dark grey



Za raspoloživost kontaktirajte  
Ave distributere  
For availability please contact  
sales dept.



Dostupni dok se ne  
rasprodaju zalihe  
Available until stock out







Proizvod za pravougaone  
kutije britanskog standarda  
Product for British standard  
rectangular box



Proizvod za  
izvoz  
For Export  
only

**“Ave Touch” staklene maske za kutiju 3 modula (rastojanje između šrafova 83,5 mm)**  
**“Ave Touch” glass front plates for rectangular 3 modules box (fixing centres 83,5 mm)**

		Opis	Description	Info	€
		<b>Za 2 komande - sa prozorčićem za simbol za personalizaciju</b> <b>For 2 controls - windows for customization labels</b>			
<b>BL</b>	<b>GO</b>	<input type="checkbox"/> 44PVT02BL/P	Sjajnobela Clear white	1	1
		<input checked="" type="checkbox"/> 44PVT02GO/P	Srebrnosiva mat Frosted silver grey	1	1
		<input checked="" type="checkbox"/> 44PVT02NAL/P	Sjajnocrna Clear absolute black	1	1
		<input checked="" type="checkbox"/> 44PVT02RPL/P	Sjajnocrvena Clear Pompeian red	1	1
<b>NAL</b>	<b>RPL</b>	<input checked="" type="checkbox"/> 44PVT02VO/P	Vodenozelena Frosted water green	1	1

**Napomena:** ✓ isporučuje se sa 1 slepim modulom 442TC13A  
 ✓ proverite da li maska savršeno prijanja na “skrivenu” komandu

**Note:** ✓ supplied with 1 blank insert 442TC13A  
 ✓ make sure that the front plate sticks perfectly to the “hidden” control devices

**Koristi se sa armaturom**  
**To be used with**



44A03



VO



<b>Spoljašnji okvir</b> <i>Finishing ring</i>		Opis	Description	Info	€
		44RNG3B	Ral 9010 bela RAL 9010 white	2	50
		44RNG3N	Sjajna tamnosiva Polished dark grey	2	50





# AVE Touch rešenja

AVE Touch Solutions



“Ave Touch” staklene maske 3 modula (rastojanje između šrafova 83,5 mm)

“Ave Touch” glass front plates for rectangular 3 modules box (fixing centres 83,5 mm)

54



BL



GO



NAL



RPL



VO



Opis Description Info €

### Za 3 “skrивene” komande For 3 “hidden” controls

□ 44PVT3BL Sjajnobela Clear white	1	1
■ 44PVT3GO Srebrnosiva mat Frosted silver grey	1	1
■ 44PVT3NAL Sjajnocrna Clear absolute black	1	1
■ 44PVT3RPL Sjajnocrvena Clear Pompeian red	1	1
■ 44PVT3VO Vodnozelena Frosted water green	1	1

**Napomena:** proverite da li maska savršeno prijanja na “skrivenu” komandu  
**Note:** make sure that the front plate sticks perfectly to the “hidden” control devices

Koristi se sa armaturom  
To be used with

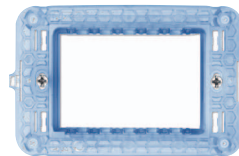

44A03

### Spoljašnji okvir Finishing ring

Opis Description Info €

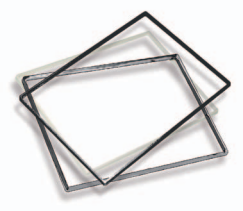

44RNG3B Ral 9010 bela RAL 9010 white	2	50
44RNG3N Sjajna tamnosiva Polished dark grey	2	50



Za raspoloživost kontaktirajte Ave distributere  
For availability please contact sales dept.



Dostupni dok se ne rasprodaju zalihe  
Available until stock out







Proizvod za pravougaone kutije britanskog standarda  
Product for British standard rectangular box



Proizvod za izvoz  
For Export only

**“Ave Touch” staklene maske za kutiju 3 modula (rastojanje između šrafova 83,5 mm)**  
**“Ave Touch” glass front plates for rectangular 3 modules box (fixing centres 83,5 mm)**

		Opis	Description	Info	€
		<b>Za 3 komande - sa prozorčićem za simbol za personalizaciju</b> <i>For 3 controls - windows for customization labels</i>			
<b>BL</b>	<b>GO</b>	<input type="checkbox"/> <b>44PVT3BL/P</b>	Sjajnobela <i>Clear white</i>	1	1
		<input checked="" type="checkbox"/> <b>44PVT3GO/P</b>	Srebrnosiva mat <i>Frosted silver grey</i>	1	1
		<input checked="" type="checkbox"/> <b>44PVT3NAL/P</b>	Sjajnocrna <i>Clear absolute black</i>	1	1
<b>NAL</b>	<b>RPL</b>	<input checked="" type="checkbox"/> <b>44PVT3RPL/P</b>	Sjajnocrvena <i>Clear Pompeian red</i>	1	1
		<input checked="" type="checkbox"/> <b>44PVT3VO/P</b>	Vodenozelena <i>Frosted water green</i>	1	1

**Napomena:** proverite da li maska savršeno prijanja na “skrivenu” komandu  
**Note:** make sure that the front plate sticks perfectly to the “hidden” control devices



**VO**

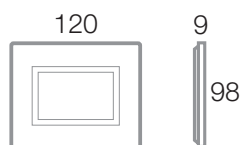

**Koristi se sa armaturom**  
*To be used with*



**44A03**



Sistema 45

<b>Spoljašnji okvir</b> <i>Finishing ring</i>		Opis	Description	Info	€
		<input type="checkbox"/> <b>44RNG3B</b>	Ral 9010 bela <i>RAL 9010 white</i>	2	50
		<input type="checkbox"/> <b>44RNG3N</b>	Sjajna tamnosiva <i>Polished dark grey</i>	2	50



# AVE Touch rešenja

AVE Touch Solutions



“Ave Touch” staklene maske za kutiju 4 modula (rastojanje između šrafova 108,5 mm)

“Ave Touch” glass front plates for rectangular 4 modules box (fixing centres 108,5 mm)

56



BL



GO



NAL



RPL



VO



Opis Description Info €

### Za 3 “skrivené” komande For 3 “hidden” controls

<input type="checkbox"/> 44PVT03BL	Sjajnobela Clear white	na upit upon request	1	1
<input checked="" type="checkbox"/> 44PVT03GO	Srebrnosiva mat Frosted silver grey	na upit upon request	1	1
<input checked="" type="checkbox"/> 44PVT03NAL	Sjajnocrna Clear absolute black	na upit upon request	1	1
<input checked="" type="checkbox"/> 44PVT03RPL	Sjajnocrvena Clear Pompeian red	na upit upon request	1	1
<input checked="" type="checkbox"/> 44PVT03VO	Vodnozelená Frosted water green	na upit upon request	1	1

**Napomena:** ✓ isporučuje se sa 2 slepa modula 442TC13R  
✓ proverite da li maska savršeno prijanja na “skrivenú” komandu

**Note:** ✓ supplied with 2 blank inserts 442TC13R  
✓ make sure that the front plate sticks perfectly to the “hidden” control devices

Koristi se sa armaturom  
To be used with

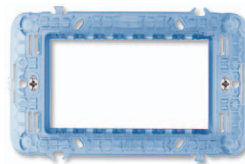

44A04

### Spoljašnji okvir Finishing ring

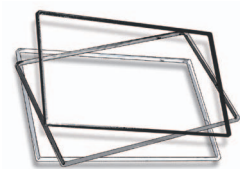

Opis Description Info €

44RNG4B	Ral 9010 bela RAL 9010 white	2	50
44RNG4N	Sjajna tamnosiva Polished dark grey	2	50



Za raspoloživost kontaktirajte  
Ave distributere  
For availability please contact  
sales dept.



Dostupni dok se ne  
rasprodaju zalihe  
Available until stock out







Proizvod za pravougaone  
kutije britanskog standarda  
Product for British standard  
rectangular box



Proizvod za  
izvoz  
For Export  
only

**“Ave Touch” staklene maske 4 modula (rastojanje između šrafova 108,5 mm)**  
**“Ave Touch” glass front plates for rectangular 4 modules box (fixing centres 108,5 mm)**

		Opis	Description	Info	€
		<b>Za 3 komande - sa prozorčićem za simbol za personalizaciju</b> <b>For 3 controls - windows for customization labels</b>			
<b>BL</b>	<b>GO</b>	<input type="checkbox"/> <b>44PVT03BL/P</b> Sjajnobela <i>Clear white</i>		na upit upon request	1 1
		<input checked="" type="checkbox"/> <b>44PVT03GO/P</b> Srebrnosiva mat <i>Frosted silver grey</i>		na upit upon request	1 1
		<input checked="" type="checkbox"/> <b>44PVT03NAL/P</b> Sjajnocrna <i>Clear absolute black</i>		na upit upon request	1 1
		<input checked="" type="checkbox"/> <b>44PVT03RPL/P</b> Sjajnocrvena <i>Clear Pompeian red</i>		na upit upon request	1 1
<b>NAL</b>	<b>RPL</b>	<input checked="" type="checkbox"/> <b>44PVT03VO/P</b> Vodenozelena <i>Frosted water green</i>		na upit upon request	1 1

**Napomena:** ✓ isporučuje se sa 2 slepa modula 442TC13R  
 ✓ proverite da li maska savršeno prijanja na “skrivenu” komandu

**Note:** ✓ supplied with 2 blank inserts 442TC13R  
 ✓ make sure that the front plate sticks perfectly to the “hidden” control devices



**VO**



**Koristi se sa armaturom**  
**To be used with**

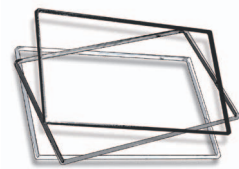

**44A04**

<b>Spoljašnji okvir</b> <i>Finishing ring</i>		Opis	Description	Info	€
		<b>44RNG4B</b> Ral 9010 bela <i>RAL 9010 white</i>			2 50
		<b>44RNG4N</b> Sjajna tamnosiva <i>Polished dark grey</i>			2 50



# AVE Touch rešenja

AVE Touch Solutions



“Ave Touch” staklene maske za kutiju 4 modula (rastojanje između šrafova 108,5 mm)

“Ave Touch” glass front plates for rectangular 4 modules box (fixing centres 108,5 mm)

58

Opis	Description	Info	€
------	-------------	------	---



BL



GO



NAL



RPL



VO



## Za 4 “skrivenne” komande For 4 “hidden” controls

□ 44PVTC4BL

Sjajnobela

Clear white

1 1

■ 44PVTC4GO

Srebrnosiva mat

Frosted silver grey

1 1

■ 44PVTC4NAL

Sjajnocrna

Clear absolute black

1 1

■ 44PVTC4RPL

Sjajnocrvena

Clear Pompeian red

1 1

■ 44PVTC4VO

Vodnozeleno

Frosted water green

1 1

**Napomena:** proverite da li maska savršeno prijanja na “skrivenne” komandu

**Note:** make sure that the front plate sticks perfectly to the “hidden” control devices

Koristi se sa armaturom  
To be used with

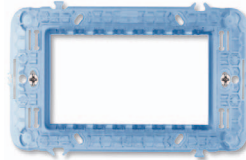

44A04

## Spoljašnji okvir Finishing ring

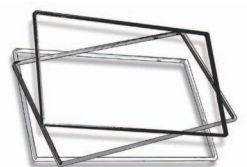

Opis	Description	Info	€
------	-------------	------	---

44RNG4B

Ral 9010 bela

RAL 9010 white

2 50

44RNG4N

Sjajna tamnosiva

Polished dark grey

2 50



Za raspoloživost kontaktirajte  
Ave distributere  
For availability please contact  
sales dept.



Dostupni dok se ne  
rasprodaju zalihe  
Available until stock out



Proizvod za pravougaone  
kutije britanskog standarda  
Product for British standard  
rectangular box



Proizvod za  
izvoz  
For Export  
only

**“Ave Touch” staklene maske za kutije 6-7 modula (rastojanje između šrafova 158,5 mm)**  
**“Ave Touch” glass front plates for rectangular 6-7 modules box (fixing centres 158,5 mm)**

59

	Opis	Description	Info	€
 <b>BL</b>   <b>NAL</b>   <b>GO</b>   <b>RPL</b>   <b>VO</b>	<b>Za 4 “skrivenene” komande</b> <b>For 4 “hidden” controls</b>			
	<input type="checkbox"/>	<b>44PVTC04BL</b> Sjajnobela Clear white	na upit upon request	1 1
	<input type="checkbox"/>	<b>44PVTC04GO</b> Srebrnosiva mat Frosted silver grey	na upit upon request	1 1
	<input type="checkbox"/>	<b>44PVTC04NAL</b> Sjajnocrna Clear absolute black	na upit upon request	1 1
	<input type="checkbox"/>	<b>44PVTC04RPL</b> Sjajnocrvena Clear Pompeian red	na upit upon request	1 1
	<input type="checkbox"/>	<b>44PVTC04VO</b> Vodenozelena Frosted water green	na upit upon request	1 1

**Napomena:** ✓ isporučuje se sa 3 slepa modula 442TC13A  
 ✓ proverite da li maska savršeno prijanja na “skrivenenu” komandu

**Note:** ✓ supplied with 3 blank inserts 442TC13A  
 ✓ make sure that the front plate sticks perfectly to the “hidden” control devices

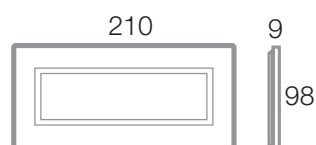

**Koristi se sa armaturom**  
**To be used with**



**44A07**

Min. pakovanje kom.  
 Min. Packaging pcs

Stand. pakovanje kom.  
 Std. Packaging pcs



# AVE Touch rešenja

AVE Touch Solutions

NEW WIRING ACCESSORIES

“Ave Touch” staklene maske za kutiju 6-7 modula (rastojanje između šrafova 158,5 mm)

“Ave Touch” glass front plates for rectangular 6-7 modules box (fixing centres 158,5 mm)

60



BL



NAL



GO



RPL

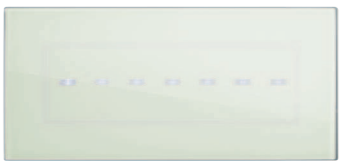

VO

Opis Description Info €

### Za 7 “skrivenih” komandi For 7 “hidden” controls

□ 44PVTG7BL	Sjajnobela Clear white	1	1
■ 44PVTG7GO	Srebrnosiva mat Frosted silver grey	1	1
■ 44PVTG7NAL	Sjajnocrna Clear absolute black	1	1
■ 44PVTG7RPL	Sjajnocrvena Clear Pompeian red	1	1
■ 44PVTG7VO	Vodnozeleno Frosted water green	1	1

**Napomena:** proverite da li maska savršeno prijanja na “skrivenu” komandu

**Note:** make sure that the front plate sticks perfectly to the “hidden” control devices

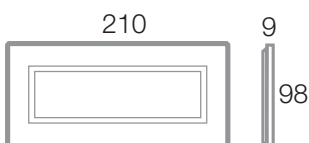

Koristi se sa armaturom  
To be used with

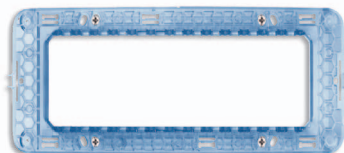

44A07



Za raspoloživost kontaktirajte Ave distributere  
For availability please contact sales dept.



Dostupni dok se ne rasprodaju zalihe  
Available until stock out







Proizvod za pravougaone kutije britanskog standarda  
Product for British standard rectangular box



Proizvod za izvoz  
For Export only

**“Ave Touch” staklene maske za kutiju BL02P**  
**“Ave Touch” glass front plates for BL02P box**

	Opis	Description	Info	€																									
	<b>BL</b>																												
	<b>GO</b>																												
	<b>NAL</b>																												
	<b>RPL</b>																												
	<b>VO</b>																												
<p><b>Za 6 (3+3) “skrivenih” komandi</b>  <b>For 6 (3+3) “hidden” controls</b></p> <table border="1"> <tr> <td><input type="checkbox"/></td> <td><b>44PVT33BL</b></td> <td>Sjajnobela Clear white</td> <td>1</td> <td>1</td> </tr> <tr> <td><input type="checkbox"/></td> <td><b>44PVT33GO</b></td> <td>Srebrnosiva mat Frosted silver grey</td> <td>1</td> <td>1</td> </tr> <tr> <td><input type="checkbox"/></td> <td><b>44PVT33NAL</b></td> <td>Sjajnocrna Clear absolute black</td> <td>1</td> <td>1</td> </tr> <tr> <td><input type="checkbox"/></td> <td><b>44PVT33RPL</b></td> <td>Sjajnocrvena Clear Pompeian red</td> <td>1</td> <td>1</td> </tr> <tr> <td><input type="checkbox"/></td> <td><b>44PVT33VO</b></td> <td>Vodenozelena Frosted water green</td> <td>1</td> <td>1</td> </tr> </table> <p><b>Napomena:</b> proverite da li maska savršeno prijanja na “skrivenu” komandu  <b>Note:</b> make sure that the front plate sticks perfectly to the “hidden” control devices</p>					<input type="checkbox"/>	<b>44PVT33BL</b>	Sjajnobela Clear white	1	1	<input type="checkbox"/>	<b>44PVT33GO</b>	Srebrnosiva mat Frosted silver grey	1	1	<input type="checkbox"/>	<b>44PVT33NAL</b>	Sjajnocrna Clear absolute black	1	1	<input type="checkbox"/>	<b>44PVT33RPL</b>	Sjajnocrvena Clear Pompeian red	1	1	<input type="checkbox"/>	<b>44PVT33VO</b>	Vodenozelena Frosted water green	1	1
<input type="checkbox"/>	<b>44PVT33BL</b>	Sjajnobela Clear white	1	1																									
<input type="checkbox"/>	<b>44PVT33GO</b>	Srebrnosiva mat Frosted silver grey	1	1																									
<input type="checkbox"/>	<b>44PVT33NAL</b>	Sjajnocrna Clear absolute black	1	1																									
<input type="checkbox"/>	<b>44PVT33RPL</b>	Sjajnocrvena Clear Pompeian red	1	1																									
<input type="checkbox"/>	<b>44PVT33VO</b>	Vodenozelena Frosted water green	1	1																									

61

Sistema 45

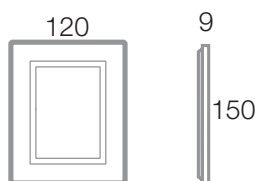

**Koristi se sa armaturom**  
**To be used with**

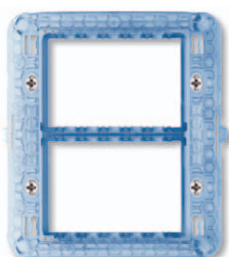

**44A33**

Min. pakovanje kom.  
Min. Packaging pcs

Stand. pakovanje kom.  
Std. Packaging pcs





# AVE Touch rešenja

AVE Touch Solutions



“Ave Touch” staklene maske za kutiju 3 modula (rastojanje između šrafova 83,5 mm)

“Ave Touch” glass front plates for rectangular 3 modules box (fixing centres 83,5 mm)

62



BL



GO

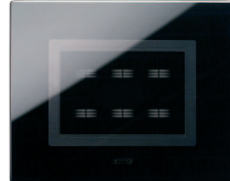

NAL

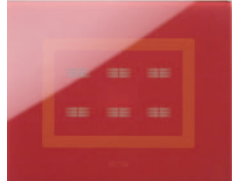

RPL



VO



Opis Description Info €

Za 6 (3+3) "skrivenih" komandi  
For 6 (3+3) "hidden" controls

□ 44PVT16BL Sjajnobela Clear white	<b>Novo</b>	1	1
■ 44PVT16GO Srebrnosiva mat Frosted silver grey	<b>Novo</b>	1	1
■ 44PVT16NAL Sjajnocrna Clear absolute black	<b>Novo</b>	1	1
■ 44PVT16RPL Sjajnocrvena Clear Pompeian red	<b>Novo</b>	1	1
■ 44PVT16VO Vodnozeleno Frosted water green	<b>Novo</b>	1	1

**Napomene:** proverite da li maska savršeno prijanja na "skrivenu" komandu  
upotrebljava se u kombinaciji sa MultiTouch komandom 442TC16

**Note:** make sure that the front plate sticks perfectly to the "hidden" control devices

Koristi se sa armaturom  
To be used with

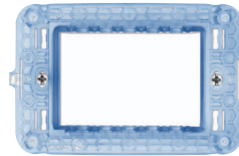

44A03

## Spoljašnji okvir Finishing ring

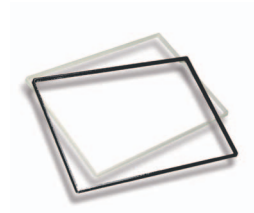

Opis Description Info €

44RNG3B Ral 9010 bela RAL 9010 white		2	50
44RNG3N Sjajnatamnosiva Polished dark grey		2	50



Za raspoloživost kontaktirajte  
Ave distributere  
For availability please contact  
sales dept.



Dostupni dok se ne  
rasprodaju zalihe  
Available until stock out







Proizvod za pravougaone  
kutije britanskog standarda  
Product for British standard  
rectangular box



Proizvod za  
izvoz  
For Export  
only

**“Ave Touch” staklene maske za kutiju 3 modula (rastojanje između šrafova 83,5 mm)**  
**“Ave Touch” glass front plates for rectangular 3 modules box (fixing centres 83,5 mm)**

		Opis	Description	Info	€
	BL	<b>Za 1 “skriveni” taster sa prozorčićem za karticu sa imenom</b> <i>For 1 “hidden” push-button module with name tag</i>			
		<input type="checkbox"/> <b>44PVTc88BL</b>	Sjajnobela <i>Clear white</i>	1	1
	GO	<input checked="" type="checkbox"/> <b>44PVTc88GO</b>	Srebrnosiva mat <i>Frosted silver grey</i>	1	1
		<input checked="" type="checkbox"/> <b>44PVTc88NAL</b>	Sjajnocrna <i>Clear absolute black</i>	1	1
	NAL	<input checked="" type="checkbox"/> <b>44PVTc88RPL</b>	Sjajnocrvena <i>Clear Pompeian red</i>	1	1
		<input checked="" type="checkbox"/> <b>44PVTc88V0</b>	Vodenozelena <i>Frosted water green</i>	1	1
	RPL				
	V0				

**Napomene:** proverite da li maska savršeno prijanja na “skrivenu” komandu  
 upotrebljava se sa Ave Touch tasterom za zvono 442TC88  
**Note:** make sure that the front plate sticks perfectly to the “hidden” control devices



Koristi se sa armaturom  
 To be used with



44A03

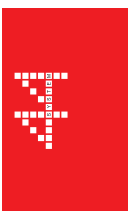

Sistema 45

Spoljašnji okvir <i>Finishing ring</i>		Opis	Description	Info	€
		<input type="checkbox"/> <b>44RNG3B</b>	Ral 9010 bela <i>RAL 9010 white</i>	2	50
		<input type="checkbox"/> <b>44RNG3N</b>	Sjajna tamnosiva <i>Polished dark grey</i>	2	50



# AVE Touch rešenja

AVE Touch Solutions



“Ave Touch” staklene maske za kutiju 3 modula (rastojanje između šrafova 83,5 mm)

“Ave Touch” glass front plates for rectangular 3 modules box (fixing centres 83,5 mm)

64



BL



GO



NAL



RPL



VO



Opis Description Info €

Za 1 “skriveni” modul za svetlosnu signalizaciju/svetiljku  
For 1 “hidden” light/lighting signal module

□ 44PVTC76BL  
Sjajnobela  
Clear white 1 1

■ 44PVTC76GO  
Srebrnosiva mat  
Frosted silver grey 1 1

■ 44PVTC76NAL  
Sjajno crna  
Clear absolute black 1 1

■ 44PVTC76RPL  
Sjajno crvena  
Clear Pompeian red 1 1

■ 44PVTC76VO  
Vodnozeleno  
Frosted water green 1 1

Napomena: za izmenljive folije vidi str. 29  
upotrebljava se sa svetlosnom signalizacijom 442TC76

Note: for interchangeable films see pag. 29

Koristi se sa armaturom  
To be used with

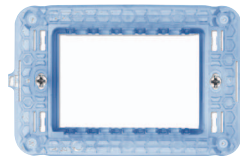

44A03

## Spoljašnji okvir Finishing ring

Opis Description Info €

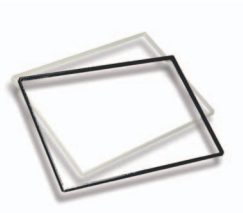

44RNG3B  
Ral 9010 bela  
RAL 9010 white 2 50

44RNG3N  
Sjajna tamnosiva  
Polished dark grey 2 50



Za raspoloživost kontaktirajte  
Ave distributere  
For availability please contact  
sales dept.



Dostupni dok se ne  
rasprodaju zalihe  
Available until stock out







Proizvod za pravougaone  
kutije britanskog standarda  
Product for British standard  
rectangular box



Proizvod za  
izvoz  
For Export  
only

**“Ave Touch” staklene maske za kutiju 3 modula (rastojanje između šrafova 83,5 mm)**  
**“Ave Touch” glass front plates for rectangular 3 modules box (fixing centres 83,5 mm)**

Opis	Description	Info	€
		<b>Klizna maska za 3 modula Sistem 44 - simbol “utičnice”</b> <i>Sliding for covering 3 mod. S44 - “plug” symbol</i>	
<b>BL</b>	<b>GO</b>	<b>□ 44PVTC3BL</b> Sjajnobela <i>Clear white</i>	1 1
		<b>■ 44PVTC3GO</b> Srebrnosiva mat <i>Frosted silver grey</i>	1 1
<b>NAL</b>	<b>RPL</b>	<b>■ 44PVTC3NAL</b> Sjajnocrna <i>Clear absolute black</i>	1 1
		<b>■ 44PVTC3RPL</b> Sjajnocrvena <i>Clear Pompeian red</i>	1 1
<b>VO</b>		<b>■ 44PVTC3VO</b> Vodenozelena <i>Frosted water green</i>	1 1

**Napomena:** ✓ koristi se samo sa specijalnim armaturama 44ATC03B ili 44ATC03GSL  
 ✓ svetleći simbol utičnice sa led lampicom koja se isporučuje sa armaturom  
 ✓ koristi se sa svim uređajima 1, 2 ili 3 modula Sistema 44 izuzev sa proizvodima na 66. strani

**Note:** ✓ to be used only with special frame 44ATC03B or 44ATC03GSL  
 ✓ “plug” symbol lightable by led supplied with the frame  
 ✓ it can be used with all the system 44 standard products 1-2 or 3 modules except for the codes on page 66

**Koristi se sa armaturom**  
**To be used with**



44ATC03GSL



44ATC03B

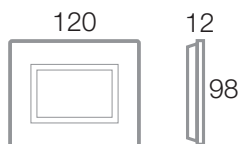

**Primer upotrebe**    *Application example*





# AVE Touch rešenja

AVE Touch Solutions



“Ave Touch” staklene maske za kutiju 3 modula (rastojanje između šrafova 83,5 mm)  
“Ave Touch” glass front plates for rectangular 3 modules box (fixing centres 83,5 mm)

66

Opis	Description	Info	€
------	-------------	------	---



BL



GO



NAL



RPL



VO

Primer upotrebe Application example

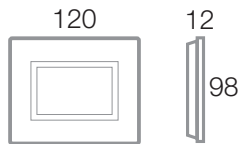

Klizna maska za 3 modula Sistem 44  
Sliding for covering 3 mod. S44

□ 44PVTN3BL Sjajnobela Clear white	1	1
■ 44PVTN3GO Srebrnosiva mat Frosted silver grey	1	1
■ 44PVTN3NAL Sjajnocrna Clear absolute black	1	1
■ 44PVTN3RPL Sjajnocrvena Clear Pompeian red	1	1
■ 44PVTN3VO Vodnozelena Frosted water green	1	1

**Napomena:** ✓ koristi se samo sa specijalnim armaturama 44ATC03B ili 44ATC03GSL  
✓ koristi se sa svim uređajima 1, 2 ili 3 modula Sistema 44 osim sa proizvodima na 66. strani

**Note:** ✓ to be used only with special frame 44ATC03B or 44ATC03GSL  
✓ it can be used with all the system 44 standard products 1-2 or 3 modules except for the codes on page 66

Koristi se sa armaturom  
To be used with



44ATC03GSL



44ATC03B

Uređaji koji se ne mogu instalirati ispod “klizne” maske

Products that can not be installed with sliding front plates



44..052X6	44..062X6	441083/2	442076	442048AE	44..048	44..048D	44..085	44..023GSR	44..085SW	44..CRT
44..052X10	44..062X10	442083								
44..052X16	44..062X16	AF44..099								

Uređaji koji se ne mogu instalirati ispod “klizne” maskama u kutije za gipskartonske zidove

Products that can not be installed with sliding front plates in boxes for hollow walls

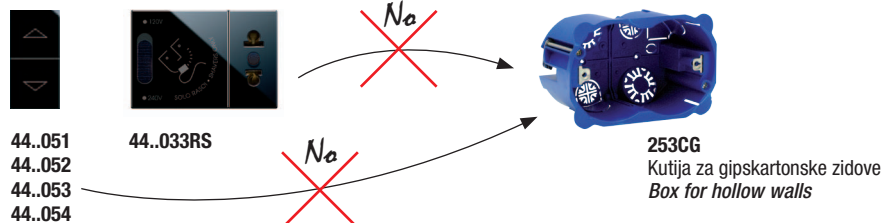

Za raspoloživost kontaktirajte Ave distributere  
For availability please contact sales dept.



Dostupni dok se ne rasprodaju zalihe  
Available until stock out



Proizvod za pravougaone kutije britanskog standarda  
Product for British standard rectangular box



Proizvod za izvoz  
For Export only

## Mogućnost personalizacije "klizne" maske

### Possibility to customize the "sliding" front plates

Ave nudi mogućnost da na "kliznim" maskama reprodukuje natpis/simbol u polju koje je na slici ispod označeno žutom bojom. Ova vrsta personalizacije vrši se primenom laserske tehnologije. Ako se željeni simbol već nalazi u prikazanoj tabeli, prilikom naručivanja dovoljno je, posle koda maske (sa kodom 44PVTCS3... simbol će biti osvetljen; sa kodom 44PVTGN3... simbol neće biti osvetljen) naznačiti "sa simbolom/natpisom broj..." prema numeraciji iz tabele ispod. U suprotnom, ukoliko se želi prikazati neki drugi simbol/natpis potrebno je dostaviti foliju ili štampani materijal simbola koji se prikazuje, sačinjen u razmeri dva ili tri puta većoj od one koja će biti prikazana na maski. Simboli se mogu dostaviti i u formatima JPG ili TIF, zajedno sa prikazom na papiru.

AVE offers the possibility to reproduce inscriptions, symbols on all the range of "sliding" front plates on the "yellow" area indicated in the picture. The customization is made by laser technology. If you can find the symbol or the inscription in the below chart, you only need to indicate in your order, after the front plate code (with the code 44PVTCS3... the customization is illuminated, with the code 44PVTGN3... the customization is not illuminated) "with symbol/inscription n°..." according to the numbering shown in the charts. For any other case, it is necessary to supply the film or a printed publication of the object to reproduce, made in a scale two or three times higher than the one to reproduce. The logos or symbols can be supplied also in a digital format in JPG or TIF, together with a print on paper.

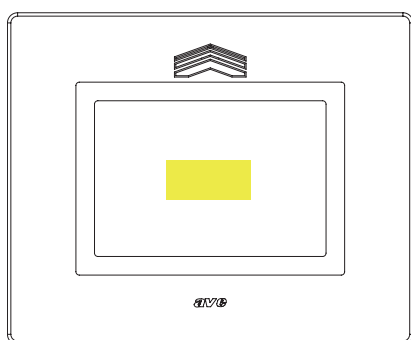

1 CARD	2 	3 	4 	5 	6 SAT	7 TV	8 Hotel
9 	10 	11 	12 	13 	14 	15 	

### Primer personalizacije Customization examples

#### Rešenja za centralizovani usisni sistem

#### Centralised vacuum system solutions



# TUBO





# AVE Touch rešenja

## AVE Touch Solutions



“Ave Touch” staklene maske za kutiju 3 modula (rastojanje između šrafova 83,5 mm) - **PERSONALIZUJUĆE**  
“Ave Touch” glass front plates for rectangular 3 modules box (fixing centres 83,5 mm) - **CUSTOMIZABLE**

68



44PVT3NAL/XX

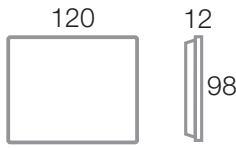

### Površina za personalizaciju pomoću lasera Laser zone

- Površina za personalizaciju laserom koja ne svetli  
Not lightable Laser zone
- Površina za personalizaciju laserom koja svetli  
Lightable Laser zone

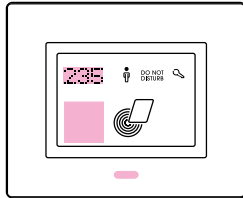

Opis	Description	Info	€
44PVT3BL/XX Sjajnobela - 3 modula Clear White - 3 modules		na upit upon request	1 1
44PVT3GO/XX Srebrnosivamat - 3 modula Frosted silver grey - 3 modules		na upit upon request	1 1
44PVT3NAL/XX Sjajnocrna - 3 modula Clear absolute black - 3 modules		na upit upon request	1 1
44PVT3RPL/XX Sjajnocrvena - 3 modula Clear Pompeian red - 3 modules		na upit upon request	1 1
44PVT3VO/XX Vodnozelena - 3 modula Frosted water green - 3 modules		na upit upon request	1 1

**Napomena:** za dodatne informacije pogledajte 453. stranu  
**Note:** for further information see page 453

“Ave Touch” staklene maske za kutiju BL02P - **PERSONALIZUJUĆE**  
“Ave Touch” glass front plates for BL02P box - **CUSTOMIZABLE**



44PVT33NAL/XX

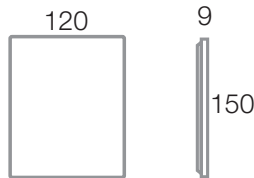

### Površina za personalizaciju pomoću lasera Laser zone

- Površina za personalizaciju laserom koja ne svetli  
Not lightable Laser zone
- Površina za personalizaciju laserom koja svetli  
Lightable Laser zone

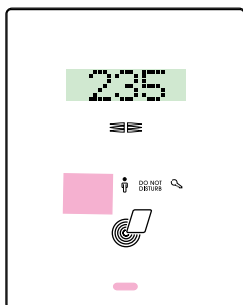

Opis	Description	Info	€
44PVT33BL/XX Sjajnobela - 6(3+3) modula Clear White - 6(3+3) modules		na upit upon request	1 1
44PVT33GO/XX Srebrnosiva mat - 6(3+3) modula Frosted silver grey - 6(3+3) modules		na upit upon request	1 1
44PVT33NAL/XX Sjajnocrna - 6(3+3) modula Clear absolute black - 6(3+3) modules		na upit upon request	1 1
44PVT33RPL/XX Sjajnocrvena - 6(3+3) modula Clear Pompeian red - 6(3+3) modules		na upit upon request	1 1
44PVT33VO/XX Vodnozelena - 6(3+3) modula Frosted water green - 6(3+3) modules		na upit upon request	1 1

**Napomena:** za dodatne informacije pogledajte 453. stranu  
**Note:** for further information see page 453

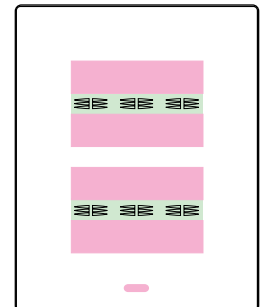
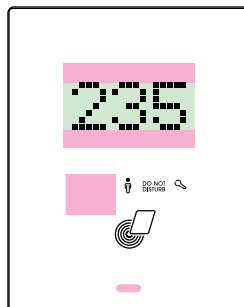

Za raspoloživost kontaktirajte Ave distributere  
For availability please contact sales dept.

Dostupni dok se ne rasprodaju zalihe  
Available until stock out

**#** Proizvod za pravougaone kutije britanskog standarda  
Product for British standard rectangular box

**△** Proizvod za izvoz  
For Export only

**“Ave Touch” maske od aluminijuma za kutiju BL02P - PERSONALIZUJUĆA**  
**“Ave Touch” aluminium front plates for BL02P box - CUSTOMIZABLE**

	Opis	Description	Info	€
		<b>44PATC33ALS/XX</b> Brušeni aluminijum - 6(3+3) modula <i>Natural brushed aluminium - 6(3+3) modules</i>	<i>na upit upon request</i>	1 1
		<b>44PATC33ANS/XX</b> Tamni brušeni aluminijum - 6(3+3) modula <i>Anthracite brushed aluminium - 6(3+3) modules</i>	<i>na upit upon request</i>	1 1

44PATC33ALS/XX

**Površina za personalizaciju pomoću lasera**  
**Laser zone**

- Površina za personalizaciju laserom koja ne svetli  
*Not lighttable Laser zone*
- Površina za personalizaciju laserom koja svetli  
*Lighttable perforable zone*

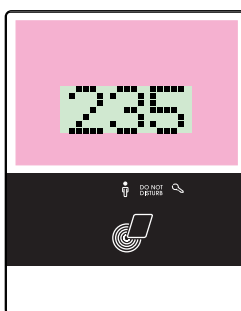

**Primer personalizacije**      *Customization examples*

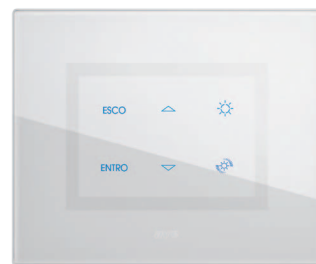
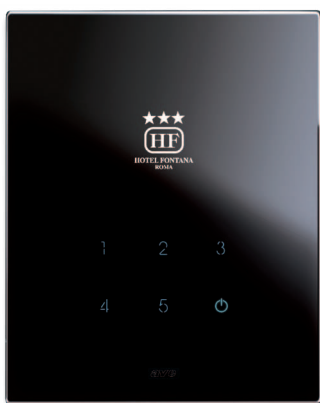

Sistema 45

Min. pakovanje kom.  
 Min. Packaging pcs

Stand. pakovanje kom.  
 Std. Packaging pcs





# Serija LIFE Touch - ALLUMIA Touch

LIFE Touch - ALLUMIA Touch series

Prekidači 250V~  
One way switches 250V~

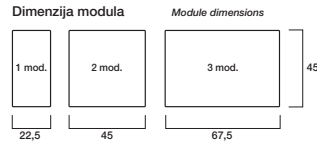

70

Life 44	Allumia	Opis	Description	Info	€
		■ <b>442001ST</b>	Mehanizam jednogpolnog prekidača 16AX sa svetlosnim indikatorom kompletira se sa tipkama od 1 ili 2 modula- 1 modul <i>1P 16AX one way lightable switch mechanism to be completed with 1 or 2 module rocker 1 module</i>	10	100
		■ <b>442001</b> ■ <b>443001</b>	Jednogpolni prekidač 16AX sa svetlosnim indikatorom - sa izmenljivom tipkom - 1 modul <i>1P 16AX one way lightable switch - interchangeable rocker - 1 module</i>	10	100
		■ <b>442001/20A</b> ■ <b>443001/20A</b>	Jednogpolni prekidač 20AX sa svetlosnim indikatorom - sa izmenljivom tipkom - 1 modul <i>1P 20AX one way lightable switch - interchangeable rocker - 1 module</i>	10	100
		■ <b>442001/2</b> ■ <b>443001/2</b>	Jednogpolni prekidač 16AX sa svetlosnim indikatorom - sa izmenljivom tipkom - 2 modula <i>1P 16AX one way lightable large switch - interchangeable rocker - 2 modules</i>	5	50
		■ <b>442001K3/10A</b> ■ <b>443001K3/10A</b>	Trostruki jednogpolni prekidač 10AX - 3 nezavisne tipke - 2 modula <i>Triple switch 1P 10AX - 3 independent rockers - 2 modules</i>	Δ	5 5
		■ <b>442001K3/20A</b> ■ <b>443001K3/20A</b>	Trostruki jednogpolni prekidač 20AX - 3 nezavisne tipke - 2 modula <i>Triple switch 1P 20AX - 3 independent rockers - 2 modules</i>	Δ	5 5
		■ <b>442010</b> ■ <b>443010</b>	Dvogpolni prekidač 16AX sa svetlosnim indikatorom - sa izmenljivom tipkom - 1 modul <i>2P 16AX one way lightable switch - interchangeable rocker - 1 module</i>	10	100
		■ <b>442010/20A</b> ■ <b>443010/20A</b>	Dvogpolni prekidač 20AX sa svetlosnim indikatorom - sa izmenljivom tipkom - 1 modul <i>2P 20AX one way lightable switch - interchangeable rocker - 1 module</i>	10	100
		■ <b>442010/2</b> ■ <b>443010/2</b>	Dvogpolni prekidač 16AX sa svetlosnim indikatorom - sa izmenljivom tipkom - 2 modula <i>2P 16AX one way lightable large switch - interchangeable rocker - 2 modules</i>	5	50
		■ <b>442071</b> ■ <b>443071</b>	Dvogpolni prekidač 10AX sa ključem - nasumično kodiranje ključa - u kompletu sa 2 ključa - izvlačenje ključa iz obe pozicije - 1 modul <i>2P 10AX one way switch with key - random key encoding - supplied with 2 keys - the key exits in both positions - 1 module</i>	1	10
		■ <b>442071MC</b>	Dvogpolni prekidač 10AX sa unificiranim ključem - šifra ključa "511" - u kompletu sa 2 ključa - izvlačenje ključa iz obe pozicije - 1 modul <i>2P 10AX one way switch with unified key - key code "511" - supplied with 2 keys - the key exits in both positions - 1 module</i>	1	10
		■ <b>442010RS/20A</b>	Dvogpolni prekidač 20AX sa svetlosnim indikatorom - crveni - 1 modul <i>2P 20AX one way lightable switch - red - 1 module</i>	1	10

**Napomena:** ✓ prekidači sa ključem 44..071 i 442071MC samo na zahtev mogu biti isporučeni sa ključem koji se može izvaditi samo u položaju otvorenog prekidača

✓ artikli sa svetlosnim indikatorom se isporučuju bez indikatorskih lampica

**Note:** ✓ 44..071 and 442071MC key switches can be supplied with key removable only in the open position upon request

✓ lightable articles are supplied without lamp



Za raspoloživost kontaktirajte Ave distributere  
For availability please contact sales dept.



Dostupni dok se ne rasprodaju zalihe  
Available until stock out









Proizvod za pravougaone kutije britanskog standarda  
Product for British standard rectangular box



Proizvod za izvoz  
For Export only

## Naizmenični prekidači 250V~ Two way switches 250V~

Life 44	Allumia	Opis	Description	Info	€
		■ <b>442002ST</b>	Mehanizam naizmeničnog jednogpolnog prekidača 16AX sa svetlosnim indikatorom, kompletira se sa tipkama 1 ili 2 modula - 1 modul <i>1P 16AX two way lightable switch mechanism to be completed with 1 or 2 module rocker - 1 module</i>		10 100
<b>442002ST</b>		■ <b>442002</b> ■ <b>443002</b>	Naizmenični jednogpolni prekidač 16AX sa svetlosnim indikatorom - sa izmenljivom tipkom - 1 modul <i>1P 16AX two way lightable switch - interchangeable rocker - 1 module</i>		10 100
		■ <b>442002/20A</b> ■ <b>443002/20A</b>	Naizmenični jednogpolni prekidač 20AX - sa izmenljivom tipkom - 1 modul <i>1P 20AX two way lightable switch - interchangeable rocker - 1 module</i>		10 100
<b>442002</b> <b>442002/20A</b>	<b>443002</b> <b>443002/20A</b>	■ <b>442002/2</b> ■ <b>443002/2</b>	Naizmenični jednogpolni prekidač 16AX - sa izmenljivom tipkom - 2 modula <i>1P 16AX two way lightable large switch - interchangeable rocker - 2 modules</i>		5 50
		■ <b>442002K3/10A</b> ■ <b>443002K3/10A</b>	Trostruki naizmenični jednogpolni prekidač 10AX - 3 nezavisne tipke - 2 modula <i>Triple 2way switch 1P 10AX - 3 independent rockers - 2 modules</i>	△	5 5
<b>442002/2</b>	<b>443002/2</b>	■ <b>442002K3/20A</b> ■ <b>443002K3/20A</b>	Trostruki naizmenični jednogpolni prekidač 20AX - 3 nezavisne tipke - 2 modula <i>Triple 2way switch 1P 20AX - 3 independent rockers - 2 modules</i>	△	5 5
<b>442002K3/10A</b> <b>442002K3/20A</b>	<b>443002K3/10A</b> <b>443002K3/20A</b>	■ <b>442072</b> ■ <b>443072</b>	Naizmenični jednogpolni prekidač 10AX sa ključem - nasumično kodiranje ključa - u kompletu sa 2 ključa - izvlačenje ključa iz obe pozicije - 1 modul <i>1P 10AX two way switch with key - random key encoding - supplied with 2 keys - the key exits in both positions - 1 module</i>		1 10
		■ <b>442072MC</b>	Naizmenični jednogpolni prekidač 10AX sa unificiranim ključem - šifra ključa "511" - u kompletu sa 2 ključa - izvlačenje ključa iz obe pozicije - 1 modul <i>1P 10AX two way switch with unified key - key code "511" - supplied with 2 keys - the key exits in both positions - 1 module</i>		1 10
<b>442072</b> <b>442072MC</b>	<b>443072</b>	<p><b>Napomena:</b> ✓ naizmenični prekidači sa ključem 44..072 i 442072MC samo na zahtev mogu biti isporučeni sa ključem koji se može izvaditi samo u položaju "0"</p> <p>✓ artikli sa svetlosnim indikatorom se isporučuju bez indikatorskih lampica</p> <p><b>Note:</b> ✓ 44..072 and 442072MC two way switches with key can be supplied with key removable only in the "0" position upon request</p> <p>✓ lightable articles are supplied without lamp</p>			

71

Sistema 45

### Komande Controls

### Naizmenični prekidači Two Way Switches

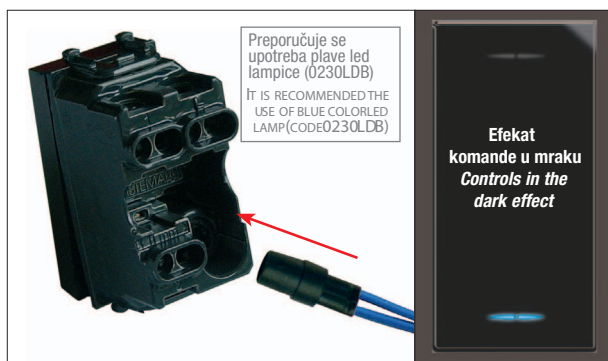

Postavljanje signalne lampice  
Lamp insertion

Komanda sa svetlosnim indikatorom: sa Life44 čak i klasične komande imaju svetlosni indikator  
*Lighted controls: with Life44 even the standard controls are lightable*

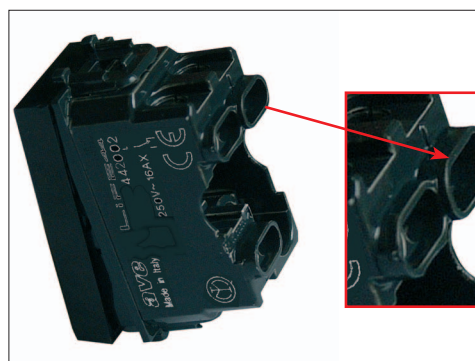

"Zajednički" priključak je izdignut radi lakšeg uočavanja  
*"Common" terminal raised for immediate identification*

Min. pakovanje kom.  
Min. Packaging pcs

Stand. pakovanje kom.  
Std. Packaging pcs







# Serija LIFE Touch - ALLUMIA Touch

LIFE Touch - ALLUMIA Touch series













Unakrsni prekidači 250V~  
Intermediate switches 250V~

72

Life 44	Allumia	Opis	Description	Info	€
		■ 442004ST	Mehanizam unakrsnog jednogpolnog prekidača 16AX sa svetlosnim indikatorom - kompletira se sa tipkama od 1 ili 2 modula - 1 modul <i>1P 16AX lightable intermediate switch mechanism to be completed with 1 or 2 module rocker 1 module</i>	10	100
442004ST		■ 442004	■ 443004 Unakrsni jednogpolni prekidač 16AX sa svetlosnim indikatorom - sa izmenljivom tipkom - 1 modul <i>1P 16AX lightable intermediate switch - interchangeable rocker - 1 module</i>	10	100
		■ 442004/20A	■ 443004/20A Unakrsni jednogpolni prekidač 20AX sa svetlosnim indikatorom - sa izmenljivom tipkom - 1 modul <i>1P 20AX lightable intermediate switch - interchangeable rocker - 1 module</i>	10	100
442004 442004/20A	443004 443004/20A	■ 442004/2	■ 443004/2 Unakrsni jednogpolni prekidač 16AX sa svetlosnim indikatorom - sa izmenljivom tipkom - 2 modula <i>1P 16AX lightable large intermediate switch - interchangeable rocker - 2 modules</i>	5	50
			<b>Napomena:</b> isporučuju se bez indikatorskih lampica <b>Note:</b> supplied without lamp		
442004/2	443004/2				

## Izmenljive tipke za prekidače, naizmenične i unakrsne prekidače

Interchangeable rockers for one way switch, two way switch and intermediate switch

Life 44	Allumia	Opis	Description	Info	€
		■ 442T	■ 443T Izmenljiva obična tipka sa svetlosnim indikatorom - 1 modul <i>Interchangeable plain lightable rocker - 1 module</i>	14	14
442T	443T	■ 442T/2	■ 443T/2 Izmenljiva obična tipka sa svetlosnim indikatorom - 2 modula <i>Interchangeable plain lightable rocker - 2 modules</i>	7	7
		■ 442T/3	■ 443T/3 Izmenljiva obična tipka sa svetlosnim indikatorom - 3 modula <i>Interchangeable plain lightable rocker - 3 modules</i>	<b>Novo</b>	2
442T/2	443T/2	■ 442TGP	■ 443TGP Izmenljiva tipka sa svetlosnim indikatorom - difuzor je vidljiv čak i po danu - 1 modul <i>Interchangeable rocker with lightable lens - diffuser visible even by daylight 1 module</i>	14	14
		■ 442TGP/2	■ 443TGP/2 Izmenljiva tipka sa svetlosnim indikatorom - difuzor je vidljiv čak i po danu - 2 modula <i>Interchangeable rocker with lightable lens - diffuser visible even in daylight 2 modules</i>	7	7
442T/3	443T/3				
		442TGP	443TGP		
		442TGP/2	443TGP/2		



Za raspoloživost kontaktirajte Ave distributere  
For availability please contact sales dept.



Dostupni dok se ne rasprodaju zalih  
Available until stock out



Proizvod za pravougaone kutije britanskog standarda  
Product for British standard rectangular box



Proizvod za izvoz  
For Export only

Tasteri 250V~  
Push buttons 250V~

Life 44	Allumia	Opis	Description	Info	€
		■ 442005ST	Mehanizam jednopolnog NO tastera 10A sa svetlosnim indikatorom - kompletira se sa 1 ili 2 modula - 1 modul <i>1P NO 10A lightable push-button mechanism to be completed with 1 or 2 module rocker 1 module</i>	10	100
442005ST		■ 442005	■ 443005 Jednopolni NO taster 10A sa svetlosnim indikatorom - sa izmenljivom tipkom - 1 modul <i>1P NO 10A lightable push-button - interchangeable rocker - 1 module</i>	10	100
		■ 442005/2	■ 443005/2 Jednopolni NO taster 10A sa svetlosnim indikatorom - sa izmenljivom tipkom - 2 modula <i>1P NO 10A large lightable push-button - interchangeable rocker - 2 modules</i>	5	50
442005 442005/2P	443005 443005/2P	■ 442005AU	■ 443005AU Jednopolni NO taster 10A sa svetlosnim indikatorom - sa izmenljivom tipkom - pozlaćeni kontakti za SELV elektronska kola - 1 modul <i>Push Button 1P NO 10A lightable - interchangeable rocker - gold-plated terminals for SELV circuits - 1 module</i>	1	10
		■ 442005/2P	■ 443005/2P Dvopolni NO taster 10A sa svetlosnim indikatorom - sa izmenljivom tipkom - 1 modul <i>2P NO 10A lightable push-button - interchangeable rocker - 1 module</i>	1	10
442005AU	443005AU	■ 442025	■ 443025 Jednopolni NO+NC taster 10A sa svetlosnim indikatorom - sa izmenljivom tipkom - 1 modul <i>1P NO+NC 10A lightable push-button - interchangeable rocker - 1 module</i>	10	10
		■ 442056	■ 443056 Jednopolni dupli NO + NO taster 10A sa svetlosnim indikatorom - bez interblok funkcije: dozvoljeno je istovremeno zatvaranje 2 strujna kola - 1 modul <i>1P NO + 1P NO 10A double push-button - lightable - without interblock : the simultaneous closure of the 2 circuits is allowed - 1 module</i>	1	10
442005/2	443005/2	■ 442056F	■ 443056F Jednopolni dupli NO + NO taster 10A sa strelicama i sa svetlosnim indikatorom - bez interblok funkcije: dozvoljeno je istovremeno zatvaranje 2 strujna kola - 1 modul <i>1P NO + 1P NO 10A double push-button with arrows - lightable - without interblock : the simultaneous closure of the 2 circuits is allowed - 1 module</i>	1	10
		■ 442017	■ 443017 Jednopolni NO+NC potezni taster 10A - vrpca od izolacionog materijala dugačka 1,5 m - 1 modul <i>1P NO+NC 10A cord operated push-button - insulating material cord 1,5 m - 1 module</i>	1	10
442025	443025	<p><b>Napomena:</b> ✓ artikli sa svetlosnim indikatorom se isporučuju bez indikatorskih lampica ✓ Pošto artikli 44..056 i 44..056F dozvoljavaju istovremeno zatvaranje 2 strujna kola, nisu pogodni za kontrolu dvosmernih motora (npr. motori od roletni, žaluzina itd.)</p> <p><b>Note:</b> ✓ lightable articles are supplied without lamp ✓ since 44..056 and 44..056F allow the contemporaneous closure of two circuits, they are not suitable for motor reversing (ex. rolling shutter, etc.)</p>			
		442056	443056		
		442056F	443056F		
		442017	443017		

nastavak see next page >

73

Sistema 45







# Serija LIFE Touch - ALLUMIA Touch

LIFE Touch - ALLUMIA Touch series



Tasteri 250V~  
Push buttons 250V~

74

Life 44	Allumia	Opis	Description	Info	€	
		■ 442075	■ 443075	Dvopolni NO taster 10A sa ključem - nasumično kodiranje ključa - isporučuje se sa 2 ključa - izvlačenje ključa samo iz pozicije OFF - 1 modul 2P NO 10A push-button with key - random key encoding - supplied with 2 keys - the key exits only in the open position - 1 module	1	10
442075 442075MC	443075 443075MC	■ 442075MC		Dvopolni NO taster 10A sa unificiranim ključem - šifra ključa "511" - isporučuje se sa 2 ključa - izvlačenje ključa samo iz pozicije OFF - 1 modul 2P NO 10A push-button with unified key - key code "511" - supplied with 2 keys - the key exits only in the open position - 1 module	1	10
		■ 442005TP/2		Jednopolni NO taster 10A sa pločicom za ime sa pozadinskim osvetljenjem - osvetljenje pomoću inkadescetne ili led lampice E10 10x28 mm tipa T10 1,5W max - isporučuje se sa led lampicom 230V~ - isporučuje se sa personalizujućom karticom za natpis - 2 modula 1P NO 10A push-button with lightable name tag - illumination by incandescent or led lamp E10 10x28 mm T10 1,5W max type - supplied with customizable name tag card - supplied with 230V~ led lamp - 2 modules	1	6
442005TP/2		■ 442025RS/2		Jednopolni NO+NC veliki svetleći taster 10A za slučaj opasnosti - crveni - 2 modula 1P NO+NC 10A large emergency lightable push-button - red - 2 modules	1	6
		442025RS/2				

**Napomena:** ✓ artikli sa svetlosnim indikatorom se isporučuju bez indikatorskih lampica  
**Note:** ✓ lightable articles are supplied without lamp

## Komande sa izmenljivim tipkama Controls with Interchangeable Rockers Taster sa karticom za natpis Push button with name tag



Skidanje tipke  
Rocker removal

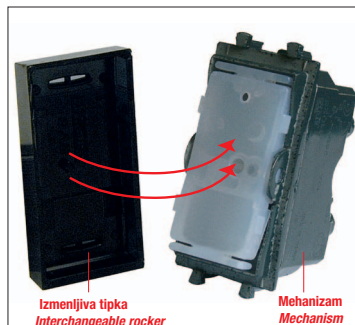

Postavljanje tipke  
Rocker assembly

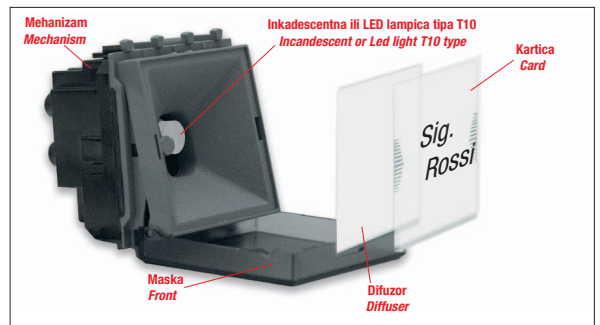

Postavljanje kartice  
Card assembly



Za raspoloživost kontaktirajte Ave distributere  
For availability please contact sales dept.



Dostupni dok se ne rasprodaju zalihe  
Available until stock out



Proizvod za pravougaone kutije britanskog standarda  
Product for British standard rectangular box



Proizvod za izvoz  
For Export only

## Izmenljive tipke za tastere

### Interchangeable rockers for push buttons

Life 44	Allumia	Opis	Description	Info	€
		■ 442T	■ 443T Izmenljiva obična tipka sa svetlosnim indikatorom - 1 modul <i>Interchangeable plain lightable rocker - 1 module</i>		14 14
442T	443T	■ 442T/2	■ 443T/2 Izmenljiva obična tipka sa svetlosnim indikatorom - 2 modula <i>Interchangeable plain lightable rocker - 2 modules</i>		7 7
		■ 442T/3	■ 443T/3 Izmenljiva obična tipka sa svetlosnim indikatorom - 3 modula <i>Interchangeable plain lightable rocker - 3 modules</i>	<b>Novo</b>	2 2
442T/2	443T/2	■ 442TGP	■ 443TGP Izmenljiva tipka sa svetlosnim indikatorom - difuzor vidljiv čak i po danu - 1 modul <i>Interchangeable rocker with lightable lens - diffuser visible even in daylight 1 module</i>		14 14
		■ 442TGP/2	■ 443TGP/2 Izmenljiva tipka sa svetlosnim indikatorom - difuzor vidljiv čak i po danu - 2 modula <i>Interchangeable rocker with lightable lens - diffuser visible even by daylight 2 modules</i>		7 7
442T/3	443T/3	■ 442TKP	■ 443TKP Izmenljiva tipka sa svetlećim simbolom KLJUČA - 1 modulo <i>Interchangeable rocker with lightable KEY symbol - 1 module</i>		14 14
		■ 442TKP/2	■ 443TKP/2 Izmenljiva tipka sa svetlećim simbolom KLJUČA - 2 modula <i>Interchangeable rocker with lightable KEY symbol - 2 modules</i>		7 7
442TKP	443TKP	■ 442TLP	■ 443TLP Izmenljiva tipka sa svetlećim simbolom SVETILJKE - 1 modul <i>Interchangeable rocker with lightable LAMP symbol - 1 module</i>		14 14
		■ 442TLP/2	■ 443TLP/2 Izmenljiva tipka sa svetlećim simbolom SVETILJKE - 2 modula <i>Interchangeable rocker with lightable LAMP symbol - 2 modules</i>		7 7
442TGP/2	443TGP/2				
					
442TKP	443TKP				
					
442TKP/2	443TKP/2				
					
442TLP	443TLP				
					
442TLP/2	443TLP/2				

nastavak see next page >

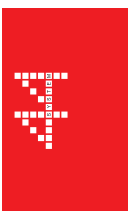

Sistema 45



# Serija LIFE Touch - ALLUMIA Touch







LIFE Touch - ALLUMIA Touch series



Izmenljive tipke za tastere

Interchangeable rockers for Push Buttons

76

Life 44	Allumia	Opis	Description	Info	€
 442TSP	 443TSP	■ 442TSP	■ 443TSP Izmenljiva tipka sa svetlećim simbolom ZVONA - 1 modul <i>Interchangeable rocker with lighttable BELL symbol - 1 module</i>	14	14
		■ 442TSP/2	■ 443TSP/2 Izmenljiva tipka sa svetlećim simbolom ZVONA - 2 modula <i>Interchangeable rocker with lighttable BELL symbol - 2 modules</i>	7	7
 442TSP/2	 443TSP/2	■ 442TLSP	■ 443TLSP Izmenljiva tipka sa svetlećim simbolom STEPENIŠNOG SVETLA - 1 modul <i>Interchangeable rocker with lighttable STAIR LIGHT symbol - 1 module</i>	14	14
		■ 442TCP	Izmenljiva tipka sa svetlećim simbolom KELNERA - 1 modul <i>Interchangeable rocker with lighttable WAITER symbol - 1 module</i>	14	14
 442TLSP	 443TLSP	■ 442TVP	■ 443TVP Izmenljiva tipka sa svetlećim simbolom VENTILATORA 1 modul <i>Interchangeable rocker with lighttable FAN COIL/VACUUM CLEANER symbol 1 module</i>	14	14
		■ 442TLTP	■ 443TLTP Izmenljiva tipka sa svetlećim simbolom STONA LAMPA - 1 modul <i>Interchangeable rocker with lighttable DESK LIGHT symbol - 1 module</i>	14	14
 442TCP		■ 442TBP	Izmenljiva tipka sa svetlećim simbolom BOJLERA - 1 modul <i>Interchangeable rocker with lighttable BOILER symbol - 1 module</i>	14	14
		■ 442TREP	Izmenljiva tipka sa svetlećim simbolom ELEKTRIČNE GREJALICE - 1 modul <i>Interchangeable rocker with lighttable ELECTRIC RESISTANCE symbol - 1 module</i>	14	14
 442TVP	 443TVP	■ 442TRESP	■ 443TRESP Izmenljiva tipka sa svetlećim simbolom RESET - 1 modul <i>Interchangeable rocker with lighttable RESET symbol - 1 module</i>	14	14
 442TBP					
 442TREP					
 442TRESP	 443TRESP				



Za raspoloživost kontaktirajte  
Ave distributere  
For availability please contact  
sales dept.



Dostupni dok se ne  
rasprodaju zalihe  
Available until stock out







Proizvod za pravougaone  
kutije britanskog standarda  
Product for British standard  
rectangular box



Proizvod za  
izvoz  
For Export  
only







## Dvosmerni prekidači za roletne 250V~ sa središnjim OFF položajem

### Rolling blind switches 250V~

Life 44	Allumia	Opis	Description	Info	€
		■ 442051	■ 443051	1	10
442051	443051	Dvosmerni jednopolni prekidač za roletne 10AX (3 priključka) - 3 položaja (središnji OFF), sa interblok funkcijom - 2 tipke sa strelicama - 1 modul			
442052	443052	Dvosmerni dvopolni prekidač za roletne 10AX (6 priključaka) - 3 položaja (središnji OFF) - sa interblok funkcijom - 2 tipke sa strelicama - 1 modul			
		■ 442053	■ 443053	1	10
442053	443053	Dvosmerni jednopolni taster za roletne 10AX (3 priključka) - 3 položaja (središnji OFF) - sa interblok funkcijom - 2 tipke sa strelicama - 1 modul			
442054	443054	Dvosmerni dvopolni taster za roletne 10AX (6 priključaka) - 3 položaja (središnji OFF) - sa interblok funkcijom - 2 tipke sa strelicama - 1 modul			

## Prekidači 230V~ i tasteri 230V~ "na dodir"

## Switches 230V~ and push button 230V~ "touch"

Life 44	Allumia	Opis	Description	Info	€
		■ 442001S	■ 443001S	1	10
442001S	443001S	Elektronski prekidač sa relejnim izlazom 1P NO 10A 230V~ - upravljanje dodirnom prednje površine ili sa više lokacija pomoću NO tastera - bistabilni režim rada - LED male potrošnje za identifikaciju u mraku - memorija stanja relejnog izlaza u slučaju nestanka struje - napajanje 230V~ - 1 modul			
		■ 442001S/2F	■ 443001S/2F	1	10
442001S/2F	443001S/2F	Elektronski prekidač na „2 žice“ 230V~ sa trijak izlazom - namenjen za rezistivna i induktivna opterećenja (inkandescentne i halogene svetiljke 40-400W, feromagnetne transformatore za halogene svetiljke niskog napona 40-400VA, induktivni elektronski transformatori 40-300VA tipa OSRAM HALOTRONIC HTM 70/230-240, HTM 102/230-240, HTM 150/230-240) - upravljanje dodirnom prednje površine ili sa više lokacija pomoću NO tastera - bistabilni režim rada - LED male potrošnje za identifikaciju u mraku - memorija stanja relejnog izlaza u slučaju nestanka struje - 1 modul			
		■ 442005S	■ 443005S	1	10
442005S	443005S	Elektronski taster na dodir za udaljenu kontrolu - upravljanje dodirivanjem prednje površine - monostabilni režim rada - LED male potrošnje za identifikaciju u mraku - napajanje 230V~ - koristi se sa 442001S, 442001S/2F ili 442048SU dimerom na dodir ili 442051S dvosmernim prekidačem - 1 modul			

**Napomena:** 44..001S/2F ne preporučuje se instalacija više od jednog prekidača u istu kutiju

**Note:** 44..001S/2F it is recommended not to install more than one switch in the same box





# Serija LIFE Touch - ALLUMIA Touch

LIFE Touch - ALLUMIA Touch series







Dvosmerni prekidači za roletne 230V~ "na dodir"  
Rolling blind switches 230V~ "touch"

78

Life 44	Allumia	Opis	Description	Info	€
		■ 442051S	■ 443051S	1	10
442051S	443051S	Elektronski dvosmerni prekidač sa 2 monostabilna relejna izlaza sa NO kontaktima 2A 230V~ - upravljanje dodirom prednje površine ili sa više lokacija pomoću NO tastera - monostabilni ili vremenski programiran režim rada - LED male potrošnje za identifikaciju u mraku - napajanje 230V~ - 1 modul <i>Electronic touch rolling blind switch with 2 monostable relay output, NO contact 2A 230V~ - Controlled by touching the frontal area or from multiple points with NO buttons - monostable or timed operating mode - Low consumption LED for identification in the dark - 230V~ power supply - 1 module</i>			





Dimer za svetiljke 230V~ "na dodir"

Dimmers for lights 230V~ "touch"

Life 44	Allumia	Opis	Description	Info	€
		■ 442048SU	■ 443048SU	1	10
442048SU	443048SU	Regulator intenziteta svetlosti 230V~ za rezistivne i induktivne potrošače (inkandescentne i halogene svetiljke 40-400W, feromagnetne transformatore za halogene svetiljke niskog napona 40-400VA, za induktivne elektronske transformatore  40-300VA tipa OSRAM HALOTRONIC HTM 70/230-240, HTM 105/230-240, HTM 150/230-240) - kontrola i podešavanje dodirom prednje površine ili sa više lokacija pomoću NO tastera - LED male potrošnje za identifikaciju u mraku - memorija nivoa i stanja relejnog izlaza u slučaju nestanka struje - 1 modul <i>230V~ dimmer for resistive and inductive loads (incandescent and halogen lamps 40-400W, ferromagnetic transformers for low voltage 40-400 VA halogen lamps, electronic inductive transformer type  40-300VA OSRAM HALOTRONIC HTM 70/230-240, HTM 105/230-240, HTM 150/230-240) - controlled by touching the frontal area or from multiple points with NO buttons - low consumption led for identification in the darkness - output and level relay status memorization in case of black out</i> 1 module			

**Napomena:** ne preporučuje se instalacija više od jednog dimera u istu kutiju  
**Note:** it is recommended not to install more than one dimmer in the same box

IC detektor prisustva za kontrolu rasvete *Detectors*

Life 44	Allumia	Opis	Description	Info	€
		■ 442068/3F	■ 443068/3F	1	6
442068/3F	443068/3F	SVETLO DOBRODOŠLICE Infracrveni detektor prisustva za kontrolu rasvete - povezivanje sa 3 žice - napajanje 230V~ - podešavanje trajanja vremenskog ciklusa (off kašnjenja) od 20s do 5 min - kontrola potrošaca 25÷200W - podešavanje svetlosne osetljivosti - fiksno sočivo dometa 9 m/150° - 1 modul <i>LUCE AMICA Infrared detector for lighting control - 3 wires cabling - 230V~ power supply - frontal duty cycle time regulation from 20 s to 5 min - 25÷200W controllable load - frontal regulation of light sensitivity - fixed lens with 9 m range and 150° opening</i> 1 module			
		■ 442068RL	■ 443068RL	<b>Novo</b>	1 6
442068RL	443068RL	SVETLO DOBRODOŠLICE Infracrveni detektor prisustva za kontrolu rasvete - relejni izlaz NO 10(4)A 230V~ - napajanje 230V~ - podešavanje trajanja vremenskog ciklusa (off kašnjenja) od 10s do 7min - podešavanje praga osetljivosti osvetljenja prostorije - fiksno sočivo dometa koji se može podešavati od 2m do 12m i otvaranja 150° - ulaz za tastere daljinske kontrole - mogućnost podešavanja režima rada: automatski/noćni/prinudno ON/Poluautomatski - 1 modul <i>LUCE AMICA Infrared motion detector for lighting control - NO 10(4)A 230V~ output relay - 230V~ power supply - Frontal duty cycle time regulation from 10 s to 7 min - Frontal regulation of light sensitivity threshold - fixed lens range from 2 m to 12 m and 150° opening - input for remote controls push buttons - possibility to set operating mode: Automatic/Night/Forced ON/Semi-Automatic - 1 module</i>			



Za raspoloživost kontaktirajte Ave distributere  
For availability please contact sales dept.



Dostupni dok se ne rasprodaju zalihe  
Available until stock out



Proizvod za pravougaone kutije britanskog standarda  
Product for British standard rectangular box



Proizvod za izvoz  
For Export only

## Elektromehanički releji Electromechanical relays

Life 44	Allumia	Opis	Description	Info	€
		<b>■ 442074M/230V</b> <b>■ 443074M/230V</b> Bistabilni elektromehanički relej - upravljanje sa više lokacija pomoću NO tastera - izlaz sa jedнопolnim kontaktom NO 10A - napajanje namotaja 230V~ - 1 modul Stepper electromechanical relay - control from multiple points with push buttons NO - 1P NO 10A output with contact - coil input 230V~ - 1 module		1	10
442074M/230V	443074M/230V				

79



Sistema 45

## Slepi moduli i izlaz za kabl *Blank inserts and Cable Outlet*

Life 44	Allumia	Opis	Description	Info	€
		<b>■ 442008</b> <b>■ 443008</b> Izlaz za kabl Ø 9 mm sa držačem kabla - omogućava prolaz kablova od Ø 4 mm do Ø 8 mm - 1 modul Cable outlet Ø 9 mm with cable grip - it allows the passage of cables from Ø 4 mm to Ø 8 mm - 1 module		10	100
442008	443008	<b>■ 442013</b> <b>■ 443013</b> Slep modul - omogućava pravljenje otvora za montažu različitih konektora Blank insert - central pre-cut in rear side to facilitate any holes - 1 module		10	300
		<b>■ 442013R</b> <b>■ 443013R</b> Slep modul - omogućava pravljenje otvora za montažu različitih konektora Blank insert - central pre-cut in rear side to facilitate any holes - 1/2 module		12	72
442013	443013	<b>■ 442013A/2</b> <b>■ 443013A/2</b> Slep modul pripremljen za kačenje na praznu kutiju za 2 modula - 2 modula Equippable blank insert - preset for clipping it to empty 2 modules box - 2 modules		4	24
442013R	443013R				
442013A/2	443013A/2				

**Napomena:** kutija za 2 modula za kačenje slepog modula 44..013A/2 može biti isporučena na zahtev  
**Note:** the 2 modules box for the 44..013A/2 blank insert clipping can be supplied upon request







# Serija LIFE Touch - ALLUMIA Touch

LIFE Touch - ALLUMIA Touch series



Radio-predajnici i radio-prijemnici  
Transmitters and radio receivers

80

Life 44	Allumia	Opis	Description	Info	€
		<b>T4R</b>	4-kanalni predajnik - omogućava prenos 4 radio komande prema prijemnicima R1R i RT1R - napajanje 230V ~ - može biti instaliran na slepi modul Life44/Allumia 44..013 ili u razvodnu kutiju - dimenzije: 40x18x33 mm 4-channel transmitter - it allows the transmission of 4 radio controls to R1R and RT1R receivers - 230Vac power supply - it can be installed on blank insert Life44/Allumia code 44..013 or in junction boxes - dimensions: 40x18x33 mm	1	1
		<b>R1R</b>	1-kanalni prijemnik - napajanje 230V ~ - snaga kontakta: 1000W/500VA na 230V ~ - može biti instaliran na slepi modul Life44/Allumia 44..013 ili u razvodnu kutiju - dimenzije: 40x18x33 mm 1-channel radio receiver - 230Vac power supply - it can be installed on blank insert Life44/Allumia code 44..013 or in junction boxes - contact load: 1000W/500VA at 230Vac - dimensions: 40x18x33 mm	1	1
		<b>RT1R</b>	1-kanalni radio-prijemnik za upravljanje elektromotorima za roletne i tende - napajanje 230V ~ - izlaz sa interblok funkcijom snage 500VA na 230V ~ - može biti instaliran na slepi modul Life44/Allumia 44..013 ili u razvodnu kutiju dimenzija 40x18x33 mm 1-channel radio receiver for rolling shutters or curtains motor control - 230Vac power supply - it can be installed on blank insert Life44/Allumia code 44..013 or in junction boxes - output with interlocked contacts with a 500VA load at 230Vac - dimensions: 40x18x33 mm	1	1
		<b>RT1R</b>	Daljinski upravljač sa 4 tastera za kontrolu radio-prijemnika - dimenzije: 41x41x10 mm 4 push button remote control for radio receivers - dimensions: 41x41x10 mm	1	1
		<b>T9R</b>	Daljinski upravljač sa 9 tastera za kontrolu radio-prijemnika - dimenzije: 41x41x10 mm 9-push button remote control for radio system. It allows to control the radio burglar alarm control units and radio receivers. Dimensions: 41x41x10 mm	1	1

AF940R



T9R

T9R+TRS1



Vidi stranu 357 See page 357

## Primer upotrebe Application example

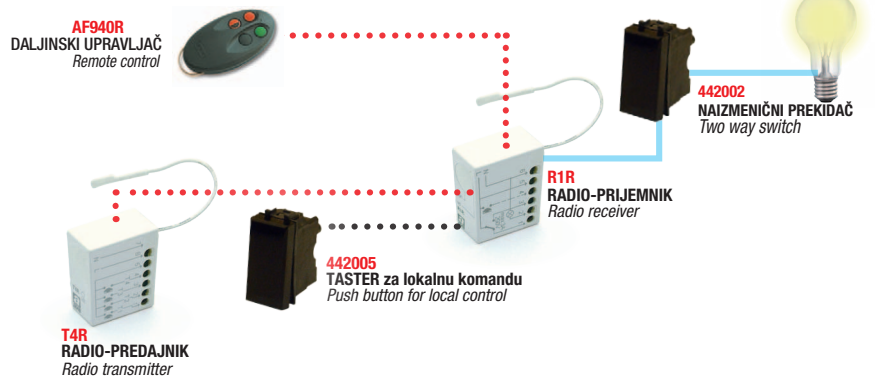

## Primer instalacije Installation example

Predajnik ili prijemnik može biti postavljen na slepi modul Life44/Allumia 44..013 i pričvršćen na odgovarajuću armaturu  
The transmitting or receiving module can be placed in the Life44/Allumia code 44..013 blank insert and clipped to the frame

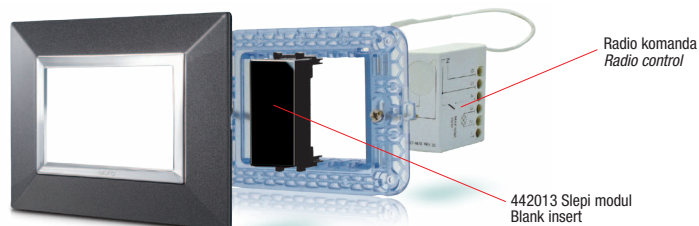

Za raspoloživost kontaktirajte Ave distributere  
For availability please contact sales dept.



Dostupni dok se ne rasprodaju zalihe  
Available until stock out



Proizvod za pravougaone kutije britanskog standarda  
Product for British standard rectangular box



Proizvod za izvoz  
For Export only

## Utičnice italijanskog standarda 250V~ 250V~ Italian standard socket outlets

Life 44	Allumia	Opis	Description	Info	€
		■ 442006/15TS ■ 443006/15TS	Kombinovana utičnica P17/11 2P+Z 10/16A - sa zaštićenim kontaktima - mogućnost upotrebe izolovanog prespojnika 442PONTE za brzo povezivanje više spojenih utičnica - 1 modul <i>Combined P17/11 Italian standard socket 2P+E 10/16A - shuttered - possibility of using insulated jumper code 442PONTE for rapid wiring of more sockets side by side - 1 module</i>	10	100
		■ 442006TS ■ 443006TS	Utičnica P11 2P+Z 10A - sa zaštićenim kontaktima - mogućnost upotrebe izolovanog prespojnika 442PONTE za brzo kabliranje više utičnica u nizu - 1 modul <i>P11 2P+E 10A socket - shuttered - possibility of using insulated jumper code 442PONTE for rapid wiring of more sockets side by side - 1 module</i>	10	100
		■ 442015TS ■ 443015TS	Utičnica P17 2P+Z 16A - sa zaštićenim kontaktima - mogućnost upotrebe izolovanog prespojnika 442PONTE za brzo kabliranje više utičnica u nizu - 1 modul <i>P17 2P+E 16A socket - shuttered - possibility of using insulated jumper code 442PONTE for rapid wiring of more sockets side by side - 1 module</i>	10	100
		■ 442090TS ■ 443090TS	Šuko utičnica P30 2P+Z 16A - sa zaštićenim kontaktima - sa svetlosnim indikatorom (signalizira prisustvo mrežnog napajanja) - bočni i centralni kontakti uzemljenja - 2 modula <i>P30 2P+E 16A Schuko socket - shuttered - lighttable (indicating the line presence) - lateral and central earth contacts - 2 modules</i>	5	50
		■ 442090TSS ■ 443090TSS	Šuko utičnica P30 2P+Z 16A sa poklopcem - sa zaštićenim kontaktima - bočni i centralni kontakti uzemljenja - 2 modula <i>P30 2P+E 16A Schuko socket with lid - shuttered - lateral and central earth contacts - 2 modules</i>	5	50
		■ 442090/15TS ■ 443090/15TS	Šuko utičnica kombinovana (UNIVRZALNA) 2P+Z 10/16A - sa zaštićenim kontaktima - sa svetlosnim indikatorom (signalizira prisustvo mrežnog napajanja) - 2 modula <i>2P+E 10/16A (UNIVERSAL) combined Schuko + Italian standard socket - shuttered - lighttable (indicating the line presence) - 2 modules</i>	5	50
		■ 442PONTE	Izolovani prespojnik za brzo kabliranje 2 utičnice italijanskog standarda u nizu 1 modul - monoblok faza/zemlja/nula - preporučuje se upotreba kablova preseka 2,5 mm <sup>2</sup> ili 4 mm <sup>2</sup> <i>Insulated jumper for rapid wiring of 2 italian standard 1 module sockets side by side single block phase/earth/neutral - recommended the use of 2,5 mm<sup>2</sup> or 4 mm<sup>2</sup> cables</i>	50	50
			<b>Napomena:</b> artikli sa svetlosnim indikatorom isporučuju se bez signalne lampice <b>Note:</b> lighttable articles are supplied without lamp		



Sistema 45

### Utičnica italijanskog standarda Standard Italian Socket Outlets



Priključak za uzemljenje je obojen radi bržeg uočavanja  
*Earth terminal highlighted for immediate identification*

### Šuko utičnica Schuko Socket Outlets

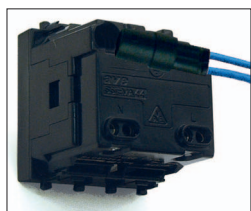

Instalacija signalne lampice  
*Inserting lamp*



Utičnica sa svetlosnim indikatorom  
*Illuminated socket outlets*

### Utičnice italijanskog standarda 1 modul Italian Standard Socket Outlets 1 module

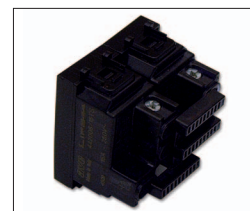

2 utičnice povezane pomoću izolovanog prespojnika  
*2 sockets wired with insulated jumper*

Preporučuje se upotreba plave led lampice (0230LDB)  
*It is recommended the use of blue color led lamp (code 0230LDB)*









# Serija LIFE Touch - ALLUMIA Touch

LIFE Touch - ALLUMIA Touch series

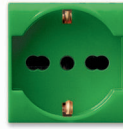

Utičnice za namenske strujne krugove 250V~  
Socket outlets for dedicated circuits 250V~

82

	Opis	Description	Info	€
 442006/15TSR	 442090/15TSR	■ 442006/15TSR Kombinovana utičnica P17/11 italijanskog standarda 2P+Z 10/16A - sa zaštićenim kontaktima - crvene boje - mogućnost upotrebe izolovanog prespojnika 442PONTE za brzo povezivanje više utičnica u nizu - 1 modul <i>Combined P17/11 Italian standard socket 2P+E 10/16A - shuttered - red - possibility of using insulated jumper code 442PONTE for rapid wiring of more sockets side by side - 1 module</i>	10	100
 442006/15TSV	 442090/15TSV	■ 442006/15TSV Kombinovana utičnica P17/11 italijanskog standarda 2P+Z 10/16A - sa zaštićenim kontaktima - zelene boje - mogućnost upotrebe izolovanog prespojnika 442PONTE za brzo povezivanje više utičnica u nizu - 1 modul <i>Combined P17/11 Italian standard socket 2P+E 10/16A - shuttered - green - possibility of using insulated jumper code 442PONTE for rapid wiring of more sockets side by side - 1 module</i>	10	100
 442006/15TSA	 442090/15TSA	■ 442006/15TSA Kombinovana utičnica P17/11 italijanskog standarda 2P+Z 10/16A - sa zaštićenim kontaktima - narandžaste boje - mogućnost upotrebe izolovanog prespojnika 442PONTE za brzo povezivanje više utičnica u nizu - 1 modul <i>Combined P17/11 Italian standard socket 2P+E 10/16A - shuttered - orange - possibility of using insulated jumper code 442PONTE for rapid wiring of more sockets side by side - 1 module.</i>	10	100
 442090TSR		■ 442090TSR Šuko utičnica P30 2P+Z 16A - sa zaštićenim kontaktima - crvene boje - sa svetlosnim indikatorom (signalizira prisustvo mrežnog napajanja) - bočni i centralni kontakt uzemljenja - 2 modula <i>P30 2P+E 16A Schuko socket - shuttered - red - lighttable (indicating the line presence) - lateral and central earth contacts - 2 modules</i>	5	50
		■ 442090/15TSR Kombinovana šuko utičnica (UNIVERZALNA) 2P+Z 10/16A - sa zaštićenim kontaktima - crvene boje - sa svetlosnim indikatorom (signalizira prisustvo mrežnog napajanja) - 2 modula <i>2P+E 10/16A (UNIVERSAL) Schuko + Italian standard socket - shuttered - red - lighttable (indicating the line presence) - 2 modules</i>	5	50
		■ 442090/15TSV Kombinovana šuko utičnica (UNIVERZALNA) 2P+Z 10/16A - sa zaštićenim kontaktima - zelene boje - sa svetlosnim indikatorom (signalizira prisustvo mrežnog napajanja) - 2 modula <i>2P+E 10/16A (UNIVERSAL) Schuko + Italian standard socket - shuttered - green - lighttable (indicating the line presence) - 2 modules</i>	5	50
		■ 442090/15TSA Kombinovana šuko utičnica (UNIVERZALNA) 2P+Z 10/16A - sa zaštićenim kontaktima - narandžaste boje - sa svetlosnim indikatorom (signalizira prisustvo mrežnog napajanja) - 2 modula <i>2P+E 10/16A (UNIVERSAL) Schuko + Italian standard socket - shuttered - orange - lighttable (indicating the line presence) - 2 modules</i>	5	50

**Napomena:** artikli sa svetlosnim indikatorom isporučuju se bez signalne lampice

**Nota:** lighttable articles are supplied without lamp

## Utičnice za aparat za brijanje 230V~ 230V~ shaver socket

Life 44	Allumia	Opis	Description	Info	€
 442033RS	 443033RS	■ 442033RS ■ 443033RS Utičnica za aparat za brijanje sa izolacionim transformatorom 20VA - evro/američki standard - napajanje 230V~ - mogućnost izbora izlaznog napona preko ugrađenog naizmeničnog prekidača 240V~ ili 120V~ - sa zaštićenim kontaktima - 3 modula <i>Shaver socket with 20VA insulating transformer - Euro-American standard - 230V~ power supply - voltage available at the output selectable by rolling blind switch 240V~ or 120V~ - shuttered - 3 modules</i>	1	1	

**Napomena:** utičnica poseduje ugrađen osigurač

**Note:** the socket is supplied with a built-in surge protection device



Za raspoloživost kontaktirajte Ave distributere  
For availability please contact sales dept.



Dostupni dok se ne rasprodaju zalihe  
Available until stock out







Proizvod za pravougaone kutije britanskog standarda  
Product for British standard rectangular box



Proizvod za izvoz  
For Export only

**Utičnice stranih standarda**  
*Various standards socket outlets*

Life 44	Allumia	Opis	Description	Info	€
		<p>■ <b>442090S</b>      ■ <b>443090S</b></p> <p>Utičnica nemački standard 2P+Z 16A 250V~ - sa zaštićenim kontaktima - sa svetlosnim indikatorom (signalizira prisustvo mrežnog napajanja) - 2 modula  <i>2P+E 16A 250V~ German standard socket - shuttered - lightable (indicating the line presence) - 2 modules</i></p>		Δ	5 50
		<p>■ <b>442090SS</b>      ■ <b>443090SS</b></p> <p>Utičnica nemački standard 2P+Z 16A 250V~ sa poklopcem - sa zaštićenim kontaktima - upotrebljava se sa kutijama minimalne dubine 45 mm - 2 modula  <i>2P+E 16A 250V~ German standard socket with lid - shuttered - to be used in boxes with min. depth 45 mm - 2 modules</i></p>		Δ	5 50

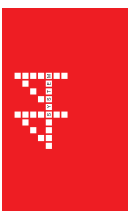

Sistema 45

**nastavak see next page >**

Min. pakovanje kom.  
 Min. Packaging pcs

Stand. pakovanje kom.  
 Std. Packaging pcs





# Serija LIFE Touch - ALLUMIA Touch

LIFE Touch - ALLUMIA Touch series





Priključnice za specijalnu namenu  
Socket outlets for special uses

84

Life 44	Allumia	Descrizione Description	Info	€
 442082USB	 443082USB	<p>■ 442082USB      ■ 443082USB</p> <p>Univerzalni USB punjač 5V 1,2A - 2 USB izalaza sa prednje strane - napajanje 110÷230V~ 50-60 Hz - omogućava punjenje mobilnih telefona, prenosivih audio uređaja, i svih ostalih elektronskih uređaja koje je moguće puniti preko USB ulaza bilo kog tipa - 2 modula  <i>Universal USB charger 5V 1,2A - 2 frontal USB outputs - powered with 110÷230V~ 50-60 Hz - allows the charging of mobile phones, mobile audio player, and all electronic devices that allows the charge through standard USB inputs</i></p>	<b>Novo</b>	1 1

## Telefonske priključnice Telephone socket outlets

Life 44	Allumia	Descrizione Description	Info	€
 442024	 443024	<p>■ 442024      ■ 443024</p> <p>Telefonska priključnica RJ11 (6 polova / 4 kontakta) - stezaljka sa šrafovimima - 1 modul  <i>J11 Telephone socket (6 poles / 4 contacts) - screw terminals - 1 module</i></p>		2 12
 442026		<p>■ 442026</p> <p>Telefonska priključnica RJ12 (6 polova / 6 kontakata) - stezaljka sa šrafovimima - 1 modul  <i>J12 Telephone socket (6 poles / 6 contacts) - screw terminals - 1 module</i></p>		1 10



Za raspoloživost kontaktirajte Ave distributere  
For availability please contact sales dept.



Dostupni dok se ne rasprodaju zalihe  
Available until stock out



Proizvod za pravougaone kutije britanskog standarda  
Product for British standard rectangular box



Proizvod za izvoz  
For Export only

## Računarske priključnice

### Data outlets

Life 44	Allumia	Opis	Description	Info	€
		■ 442027C5E ■ 443027C5E	Priključnica Ave RJ45 kategorija 5e UTP - neoklopljena - žabice za spajanje kabela uz pomoć alata - T568A i T568B standard - 8 kontakata - 1 modul <i>RJ45 category 5 enhanced outlet - not shuttered - AVE connector - insulation piercing terminals - T568A and T568B universal wiring - 8 contacts - 1 module</i>	1	10
442027C5E	443027C5E	■ 442027C6 ■ 443027C6	Priključnica Ave RJ45 kategorija 6 UTP - neoklopljena - žabice za spajanje kabela uz pomoć alata - T568A i T568B standard - 8 kontakata - 1 modul <i>RJ45 category 6 outlet - not shuttered - AVE connector - insulation piercing terminals - T568A and T568B universal wiring - 8 contacts - 1 module</i>	1	10
		■ 442028C5E ■ 443028C5E	Priključnica AMP RJ45 kategorija 5e UTP - neoklopljena - žabice za spajanje kabela uz pomoć alata - T568A i T568B standard - 8 kontakata - 1 modul <i>RJ45 category 5 enhanced outlet - not shuttered - AMP connector - insulation piercing terminals - T568A and T568B universal wiring - 8 contacts - 1 module</i>	1	10
442027C6	443027C6	■ 442028C5ES ■ 443028C5ES	Priključnica AMP RJ45 kategorija 5e FTP - oklopljena - žabice za spajanje kabela uz pomoć alata - T568A i T568B standard - 8 kontakata - 1 modul <i>RJ45 category 5 enhanced outlet - shuttered - AMP connector - insulation piercing terminals - T568A and T568B universal wiring - 8 contacts - 1 module</i>	1	10
		■ 442028C6 ■ 443028C6	Priključnica AMP RJ45 kategorija 6 UTP - neoklopljena - žabice za spajanje kabela uz pomoć alata - T568A i T568B standard - 8 kontakata - 1 modul <i>RJ45 category 6 outlet - not shuttered - AMP connector - insulation piercing terminals - T568A and T568B universal wiring - 8 contacts - 1 module</i>	1	10
442028C5E 442028C6	443028C5E 443028C6	■ 442028C6S ■ 443028C6S	Priključnica AMP RJ45 kategorija 6 FTP - neoklopljena - žabice za spajanje kabela uz pomoć alata - T568A i T568B standard - 8 kontakata - 1 modul <i>RJ45 category 6 outlet - shuttered - AMP connector - insulation piercing terminals - T568A and T568B universal wiring - 8 contacts - 1 module</i>	1	10
		■ 442029C5E ■ 443029C5E	Priključnica 3M RJ45 kategorija 5e UTP - neoklopljena - žabice za brzo spajanje kabela bez alata - T568A i T568B standard - 8 kontakata - poklopac protiv prašine ugrađen na konektor - 1 modul <i>RJ45 category 5 enhanced outlet - not shuttered - 3M connector - insulation piercing terminals with rapid wiring - T568A and T568B universal wiring 8 contacts - anti-dust lid integrated in the connector - 1 module</i>	1	10
442028C5ES 442028C6S		■ 442029C5ES ■ 443029C5ES	Priključnica 3M RJ45 kategorija 5e FTP - oklopljena - žabice za brzo spajanje kabela bez alata - T568A i T568B standard - 8 kontakata - poklopac protiv prašine ugrađen na konektor - 1 modul <i>RJ45 category 5 enhanced outlet - shuttered - 3M connector - insulation piercing terminals with rapid wiring - T568A and T568B universal wiring 8 contacts - anti-dust lid integrated in the connector - 1 module</i>	1	10
		■ 442029C6 ■ 443029C6	Priključnica 3M RJ45 kategorija 6 UTP - neoklopljena - žabice za brzo spajanje kabela bez alata - T568A i T568B standard - 8 kontakata - poklopac protiv prašine ugrađen na konektor - 1 modul <i>RJ45 category 6 outlet - not shuttered - 3M connector - insulation piercing terminals with rapid wiring - T568A and T568B universal wiring - 8 contacts - anti-dust lid integrated in the connector - 1 module</i>	1	10
442029C5E 442029C6	443029C5E 443029C6	■ 442029C6S ■ 443029C6S	Priključnica 3M RJ45 kategorija 6 FTP - oklopljena - žabice za brzo spajanje kabela bez alata - T568A i T568B - 8 kontakata - poklopac protiv prašine ugrađen na konektor - 1 modul <i>RJ45 category 6 outlet - shuttered - 3M connector - insulation piercing terminals with rapid wiring - T568A and T568B universal wiring - 8 contacts - anti-dust lid integrated in the connector - 1 module</i>	1	10
					
442029C5ES 442029C6S	443029C5ES 443029C6S				

**Napomena:** Na gornjem delu priključnice nalazi se prozorčić sa karticom za ispisivanje oznake instalirane priključnice

**Note:** on the upper part there is a transparent glass with card to allow the installer/user to identify the type of outlet



Sistema 45

Min. pakovanje kom.  
Min. Packaging pcs

Stand. pakovanje kom.  
Std. Packaging pcs





# Serija LIFE Touch - ALLUMIA Touch

LIFE Touch - ALLUMIA Touch series







Priključnica za optički kabl  
Socket for optical fibre

86

Life 44	Allumia	Opis	Description	Info	€
		■ 442029FO	Priključnica za optički kabl - SG standard - 3M konektor - VF-45 sa dva vlakna - poklopac protiv prašine ugrađen na konektor - moguća višestruka upotreba - 1 modul Socket for optical fibre duplex - SG standard - 3M connector - VF-45 with double fibre - anti-dust cover integrated in the connector - reusable - 1 module	1	10

## Adapteri za RJ45 konektore i AVE signalne konektore Adaptors for RJ45 connectors and AVE signal connectors

Life 44	Allumia	Opis	Description	Info	€
		■ 442029SC ■ 443029SC	Adapter za konektore RJ45 3M, AT&T, CEAM-QUBIX, KRONE, CLIPSAL, AMPHENOL, FANTON ili konektore AVE RJ11, RJ45, RCA, TV, itd. - 1 modul Adaptor for RJ45 3M, AT&T, CEAM-QUBIX, KRONE, CLIPSAL, AMPHENOL, FANTON or AVE RJ11, RJ45, RCA, TV, etc. connectors - 1 module	4	4
442029SC 442030SC	443029SC 443030SC	■ 442030SC ■ 443030SC	Adapter za konektore RJ45 AMP, RSX, BRAND-REX - 1 modul Adaptor for RJ45 AMP, RSX, BRAND-REX connectors - 1 module	4	4
		■ 442031SC	Adapter za konektore RJ45 PANDUIT - 1 modul Adaptor for RJ45 PANDUIT connectors - 1 module	4	4
442031SC 442032SC	443032SC	■ 442032SC ■ 443032SC	Adapter za konektore RJ45 Infra+ Schneider electric - 1 modul Adaptor for RJ45 Infra + Schneider electric connectors - 1 module	4	4
		■ 442029SC/2C	Adapter za 2 konektora AVE TV, RCA, BNC - 1 modul Adaptor for n. 2 AVE TV, RCA, BNC connectors - 1 module	4	4

**Napomena:** 44..029SC, 44..030SC, 442031SC, 44..032SC na gornjem delu adaptera nalazi se prozorčić sa karticom za ispisivanje oznake instalirane priključnice  
**Note:** 44..029SC, 44..030SC, 442031SC, 44..032SC - on the upper part there is a transparent glass with card to allow the installer/user to identify the type of outlet

## Računarske priključnice 3M 3M Data outlets Računarske priključnice i adapteri Data outlets and adaptors



Kartica za identifikaciju  
Identification card

Poklopac protiv prašine ugrađen na konektor  
Anti dust cover integrated with the connector

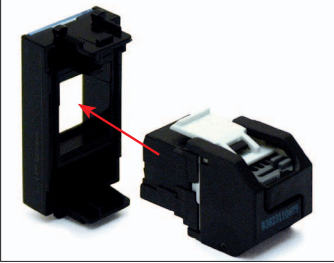



Kačenje konektora na adapter  
Connector clipping to the adapter



Otkaćinjanje  
Unclipping

## Direktna TV priključnica Ø 9,5 mm Direct TV socket outlet Ø 9,5 mm

Life 44	Allumia	Opis	Description	Info	€
		■ 442091 ■ 443091	Direktna TV priključnica sa ženskim IEC 60169-2 konektorom - frekventni opseg 40÷862 MHz - dolazni priključak sa stezaljkom sa šrafova - 1 modul Direct TV socket outlet with IEC 60169-2 female connector - frequency range 40÷862 MHz - incoming connection with screw terminal - 1 module		1 10

**Napomena:** priključnica se može upotrebljavati isključivo izvan zemalja EU  
**Note:** to be used only in non-EU Countries

Za raspoloživost kontaktirajte Ave distributere  
For availability please contact sales dept.

Dostupni dok se ne rasprodaju zalihe  
Available until stock out

# Proizvod za pravougaone kutije britanskog standarda  
Product for British standard rectangular box

△ Proizvod za izvoz  
For Export only

TV priključnice TV Ø 9,5 mm  
TV socket outlets Ø 9,5 mm

Life 44	Allumia	Opis	Description	Info	€
		<p>■ 442096MSI    ■ 443096MSI</p> <p>Direktna izolovana TV priključnica sa muškim IEC 60169-2 konektorom - frekventni opseg 4÷2400 MHz - prolazno slabljenje 1dB - NE dozvoljava prolaz jednosmerne struje i kontrolnih signala - dolazni priključak sa stezaljkama sa šraфом</p> <p>-1 modul</p> <p>Direct <b>isolated</b> TV socket with male IEC 60169-2 outlet - for frequencies 4÷2400 MHz - attenuation 1dB - it does NOT allow the direct current and control signals passage-input connection through screw terminal - 1 module</p>		1	10
442096MSI	443096MSI	<p><b>Napomena:</b> na gornjem delu priključnice nalazi se prozorčić sa karticom za ispisivanje oznake instalirane priključnice</p> <p><b>Note:</b> on the upper part there is a transparent glass with card to allow the installer/user to identify the type of outlet</p>			



Sistema 45

TV/SAT koaksijalne priključnice sa CAP - Ø9,5 mm - Pribor TV/SAT coaxial outlets - Ø 9,5 mm - Accessories

Life 44	Allumia	Opis	Description	Info	€
		<p>■ 442096IM    ■ 443096IM</p> <p>Direktna TV/SAT koaksijalna priključnica sa muškim IEC 60169-2 konektorom za frekvencije do 2400 MHz - dolazni priključak sa ženskim F konektorom - u kompletu sa plastičnom kapičom (CAP) za priključak koaksijalnog kabla</p> <p>- 1 modul</p> <p>TV/SAT direct coaxial outlet with IEC 60169-2 male connector for frequencies until 2400 MHz - incoming connection through F male connector - supplied with moulded connector (CAP) for coaxial cable connection - 1 module</p>		1	10
442096IM	443096IM				
		<p>■ 442096F    ■ 443096F</p> <p>Direktna TV/SAT koaksijalna priključnica sa ženskim F konektorom za frekvencije do 2400 MHz - dolazni priključak sa ženskim F konektorom - u kompletu sa plastičnom kapičom (CAP) za priključak koaksijalnog kabla</p> <p>- 1 modul</p> <p>TV/SAT direct coaxial outlet with F female connector for frequencies until 2400 MHz - incoming and outgoing connection through F male connector - supplied with moulded connector (CAP) for coaxial cable connection - 1 module</p>		1	10
442096F	443096F				
		<p>■ 442096IF    ■ 443096IF</p> <p>Direktna TV/SAT koaksijalna priključnica sa ženskim IEC 60169-2 konektorom za frekvencije do 2400 MHz - dolazni priključak sa ženskim F konektorom - u kompletu sa plastičnom kapičom (CAP) za priključak koaksijalnog kabla</p> <p>- 1 modul</p> <p>TV/SAT direct coaxial outlet with IEC 60169-2 female connector for frequencies until 2400 MHz - incoming connection through F male connector - supplied with moulded connector (CAP) for coaxial cable connection - 1 module</p>		1	10
442096IF	443096IF				
		<p>■ TVDER-DB6</p> <p>TV/SAT induktivni razdelnik, povezuje se na priključnice 442096IM, 442096IF, 442096F</p> <p>- prolazno slabljenje 6dB</p> <p>TV/SAT inductive shunt to be connected to 442096IM, 442096IF, 442096F</p> <p>- attenuation 6dB</p>		1	6
TVDER-DB6 TVDER-DB10 TVDER-DB14					
		<p>■ TVDER-DB10</p> <p>TV/SAT induktivni razdelnik, povezuje se na priključnice 442096IM, 442096IF, 442096F</p> <p>- prolazno slabljenje 10dB</p> <p>TV/SAT inductive shunt to be connected to 442096IM, 442096IF, 442096F</p> <p>- attenuation 10dB</p>		1	6
		<p>■ TVDER-DB14</p> <p>TV/SAT induktivni razdelnik, povezuje se na priključnice 442096IM, 442096IF, 442096F</p> <p>- prolazno slabljenje 14dB</p> <p>TV/SAT inductive shunt to be connected to 442096IM, 442096IF, 442096F</p> <p>- attenuation 14dB</p>		1	6

**Napomena:** ✓ 44..096IM, 44..096F, 44..096IF na gornjem delu priključnice se nalazi prozorčić sa karticom za ispisivanje oznake instalirane priključnice

✓ TVDER-DB... omogućavaju promenu priključnica 442096IM, 442096IF, 442096F iz direktnih u prolazne

**Note:** ✓ 44..096IM, 44..096F, 44..096IF - on the upper part there is a transparent glass with card to allow the installer/user to identify the type of outlet

TVDER-DB... they allow to change the 442096IM, 442096IF, 442096F outlets from direct to through line

Min. pakovanje kom.  
Min. Packaging pcs

Stand. pakovanje kom.  
Std. Packaging pcs









# Serija LIFE Touch - ALLUMIA Touch

LIFE Touch - ALLUMIA Touch series



TV/SAT priključnice Ø 9,5 mm  
TV/SAT coaxial outlets Ø 9,5 mm

88

Life 44	Allumia	Opis	Description	Info	€
 442096	 443096	<p>■ 442096</p> <p>Direktna TV/SAT priključnica sa ženskim IEC 60169-2 konektorom za frekvencije 4÷2400 MHz - prolazno slabljenje 1dB - omogućava prolaz jednosmerne struje i kontrolnih signala (24V 300mA max) - dolazni priključak sa stezaljkama sa šrafova - 1 modul</p> <p><i>Direct TV/SAT outlet with female IEC 60169-2 connector - for frequencies 4÷2400 MHz - attenuation 1dB - it allows direct current and control signals through (24V 300mA max) - input connection through screw terminal - 1 module</i></p>	<p>■ 443096</p> <p>Direktna TV/SAT priključnica sa ženskim IEC 60169-2 konektorom za frekvencije 4÷2400 MHz - prolazno slabljenje 1dB - omogućava prolaz jednosmerne struje i kontrolnih signala (24V 300mA max) - dolazni priključak sa stezaljkama sa šrafova - 1 modul</p> <p><i>Direct TV/SAT outlet with female IEC 60169-2 connector - for frequencies 4÷2400 MHz - attenuation 1dB - it allows direct current and control signals through (24V 300mA max) - input connection through screw terminal - 1 module</i></p>	1	10
 442096M	 443096M	<p>■ 442096M</p> <p>Direktna TV/SAT priključnica sa muškim IEC 60169-2 konektorom za frekvencije 4÷2400 MHz - prolazno slabljenje 1dB - omogućava prolaz jednosmerne struje i kontrolnih signala (24V 300mA max) - dolazni priključak sa stezaljkama sa šrafova - 1 modul</p> <p><i>Direct TV/SAT outlet with male IEC 60169-2 connector - for frequencies 4÷2400 MHz - attenuation 1dB - it allows direct current and control signals through (24V 300mA max) input connection through screw terminals - 1 module</i></p>	<p>■ 443096M</p> <p>Direktna TV/SAT priključnica sa muškim IEC 60169-2 konektorom za frekvencije 4÷2400 MHz - prolazno slabljenje 1dB - omogućava prolaz jednosmerne struje i kontrolnih signala (24V 300mA max) - dolazni priključak sa stezaljkama sa šrafova - 1 modul</p> <p><i>Direct TV/SAT outlet with male IEC 60169-2 connector - for frequencies 4÷2400 MHz - attenuation 1dB - it allows direct current and control signals through (24V 300mA max) input connection through screw terminals - 1 module</i></p>	1	10
 442096M/DB6 442096M/DB10 442096M/DB14	 443096M/DB6	<p>■ 442096M/DB6</p> <p>Prolazna TV/SAT priključnica sa muškim IEC 60169-2 konektorom za frekvencije 4÷2400 MHz - prolazno slabljenje 6dB - dolazni priključak sa stezaljkama sa šrafova - 1 modul</p> <p><i>Through line TV/SAT outlet with male IEC 60169-2 connector - for frequencies 4÷2400 MHz - attenuation 6dB - input connection through screw terminal - 1 module</i></p>	<p>■ 443096M/DB6</p> <p>Prolazna TV/SAT priključnica sa muškim IEC 60169-2 konektorom za frekvencije 4÷2400 MHz - prolazno slabljenje 6dB - dolazni priključak sa stezaljkama sa šrafova - 1 modul</p> <p><i>Through line TV/SAT outlet with male IEC 60169-2 connector - for frequencies 4÷2400 MHz - attenuation 6dB - input connection through screw terminal - 1 module</i></p>	1	10
		<p>■ 442096M/DB10</p> <p>Prolazna TV/SAT priključnica sa muškim IEC 60169-2 konektorom za frekvencije 4÷2400 MHz - prolazno slabljenje 10dB - dolazni priključak sa stezaljkama sa šrafova - 1 modul</p> <p><i>Through line TV/SAT outlet with male IEC 60169-2 connector - for frequencies 4÷2400 MHz - attenuation 10dB - input connection through screw terminal - 1 module</i></p>	<p>■ 443096M/DB10</p> <p>Prolazna TV/SAT priključnica sa muškim IEC 60169-2 konektorom za frekvencije 4÷2400 MHz - prolazno slabljenje 10dB - dolazni priključak sa stezaljkama sa šrafova - 1 modul</p> <p><i>Through line TV/SAT outlet with male IEC 60169-2 connector - for frequencies 4÷2400 MHz - attenuation 10dB - input connection through screw terminal - 1 module</i></p>	1	10
		<p>■ 442096M/DB14</p> <p>Prolazna TV/SAT priključnica sa muškim IEC 60169-2 konektorom za frekvencije 4÷2400 MHz - prolazno slabljenje 14dB - dolazni priključak sa stezaljkama sa šrafova - 1 modul</p> <p><i>Through line TV/SAT outlet with male IEC 60169-2 connector - for frequencies 4÷2400 MHz - attenuation 14dB - input connection through screw terminal - 1 module</i></p>	<p>■ 443096M/DB14</p> <p>Prolazna TV/SAT priključnica sa muškim IEC 60169-2 konektorom za frekvencije 4÷2400 MHz - prolazno slabljenje 14dB - dolazni priključak sa stezaljkama sa šrafova - 1 modul</p> <p><i>Through line TV/SAT outlet with male IEC 60169-2 connector - for frequencies 4÷2400 MHz - attenuation 14dB - input connection through screw terminal - 1 module</i></p>	1	10

**Napomena:** na gornjem delu priključnice se nalazi prozorčić sa karticom za ispisivanje oznake instalirane priključnice

**Note:** on the upper part there is a transparent glass with card to allow the installer/user to identify the type of outlet

## TV/SAT priključnice

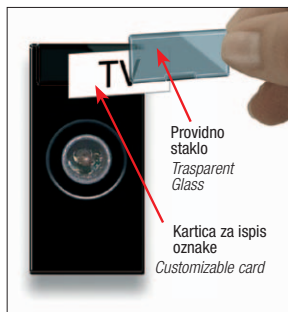

Postavljanje kartice za obeležavanje TV/SAT priključnice  
Application of the card to diversify TV/SAT



Za raspoloživost kontaktirajte Ave distributere  
For availability please contact sales dept.



Dostupni dok se ne rasprodaju zalihe  
Available until stock out



Proizvod za pravougaone kutije britanskog standarda  
Product for British standard rectangular box



Proizvod za izvoz  
For Export only

TV/SAT sa 2 ili 3 konektora  
TV/SAT outlets with 2 and 3 connectors

Life 44	Allumia	Opis	Description	Info	€
		<p>■ 442096/2PU ■ 443096/2PU</p> <p>Direktna TV-FM/SAT priključnica - 2 sa muškim i ženskim konektorima IEC 60169-2 - za frekvencije 4÷2400 MHz - prolazno slabljenje 5dB - omogućava prolaz jednosmerne struje i kontrolnih signala (24V 300mA max) preko ženskog konektora - dolazni priključak sa stezaljkama sa šraфом - 2 modula</p> <p><i>Direct TV-FM/SAT duplex outlet with IEC 60169-2 male and female connectors - frequency range 4÷2400 MHz - Attenuation 5 dB - it allows direct current and control signals (24V 300mA max) through the female connector - Incoming connection with screw terminal - 2 modules</i></p>		1	6
		<p>■ 442096/2PU/DB10</p> <p>Prolazna TV-FM/SAT priključnica - 2 sa muškim i ženskim konektorima IEC 60169-2 - za frekvencije 4÷2400 MHz - prolazno slabljenje 10dB - dolazni priključak sa stezaljkama sa šraфом - 2 modula</p> <p><i>Through line TV-FM/SAT duplex outlet with IEC 60169-2 male and female connectors - frequency range 4÷2400 Mhz - Attenuation 10dB - incoming connection with screw terminal - 2 modules</i></p>		1	6
442096/2PU/DB10 442096/2PU/DB15 442096/2PU/DB20				na upit upon request	
		<p>■ 442096/3PU ■ 443096/3PU</p> <p>Direktna TV-FM/SAT priključnica - 2 sa muškim i ženskim konektorima IEC 60169-2 - za frekvencije 4÷2400 MHz - prolazno slabljenje 15dB - dolazni priključak sa stezaljkama sa šraфом - 2 modula</p> <p><i>Through line TV-FM/SAT duplex outlet with IEC 60169-2 male and female connectors - frequency range 4÷2400 Mhz - Attenuation 15dB - incoming connection with screw terminal - 2 modules</i></p>		1	6
442096/3PU	443096/3PU			na upit upon request	
		<p>■ 442096/2PU/DB20</p> <p>Prolazna TV-FM/SAT priključnica - 2 sa muškim i ženskim konektorima IEC 60169-2 - za frekvencije 4÷2400 MHz - prolazno slabljenje 20dB - dolazni priključak sa stezaljkama sa šraфом - 2 modula</p> <p><i>Through line TV-FM/SAT duplex outlet with IEC 60169-2 male and female connectors - frequency range 4÷2400 Mhz - Attenuation 20dB - incoming connection with screw terminal - 2 modules</i></p>		1	6
		<p>■ 442096/3PU ■ 443096/3PU</p> <p>Direktna TV-FM/SAT priključnica - sa muškim TV IEC 60169-2 konektorom, IEC 60169-2 ženskim radio konektorom, i ženskim SAT F konektorom - za frekvencije 4÷2400 MHz - prolazno slabljenje 1dB - omogućava prolaz jednosmerne struje i kontrolnih signala (24V 300mA max) preko F ženskog konektora - dolazni priključak sa stezaljkama sa šraфом - 2 modula</p> <p><i>Direct TV-FM/SAT triplex outlet with IEC 60169-2 male TV connector, IEC 60169-2 female radio connector and SAT female F-type connector - frequency range 4÷2400 MHz - Attenuation 1dB - it allows direct current and control signals (24V 300mA max) passage through the female F-type connector - incoming connection with screw terminal - 2 modules</i></p>		1	6
		<p><b>Napomena:</b> 44..096/3PU za optimalan rad priključnice, treba koristiti sve izlaze</p> <p><b>Note:</b> 44..096/3PU for a perfect functioning of the outlet, all the connectors must be used</p>			







# Serija LIFE Touch - ALLUMIA Touch

LIFE Touch - ALLUMIA Touch series



Pribor za TV instalacije  
Accessories for TV coaxial outlets

90

	Opis	Description	Info	€
 CAP	 TVSPIM	<b>CAP</b> Plastični konektor (kapica) za koaksijalne kablove - omogućava brzo i jeftino povezivanje - koristi se sa priključnicama 44..096F, 44..096IM, 44..096IF <i>Plastic connector for coaxial cables - it allows a fast and cheap connection - to be used with 44..096F, 44..096IM, 44..096IF sockets</i>	50	50
 TVSPIF	 TVSPF	<b>TVGC</b> Konektor za nastavljjanje koaksijalnih kablova za frekvencije do 2400 MHz - konektori F ženski/F ženski - u kompletu sa 2 plastične kapice (CAP) <i>Shuttered junction connector for cables for frequencies up to 2400 MHz F female-F female connectors - supplied with n. 2 plastic connectors (CAP)</i>	50	50
 TVGC		<b>TVSPIM</b> Završetak koaksijalnog kabla sa muškim IEC konektorom TV/SAT z - za frekvencije do 2400MHz- u kompletu sa 1 plastičnom kapičom (CAP) <i>Shuttered TV/SAT movable plug for frequencies up to 2400 MHz Male IEC connector - supplied with n.1 plastic connector (CAP)</i>	50	50
 TVSPIF		<b>TVSPIF</b> Završetak koaksijalnog kabla sa ženskim IEC konektorom (TV/SAT) za frekvencije do 2400 MHz -u kompletu sa 1 plastičnom kapičom (CAP) <i>Shuttered TV/SAT movable plug for frequencies up to 2400 MHz Female IEC connector - supplied with n.1 plastic connector (CAP)</i>	50	50
 TVFST		<b>TVSPF</b> Završetak koaksijalnog kabla sa muškim F konektorom (TV/SAT) - za frekvencije do 2400MHz- u kompletu sa 1 plastičnom kapičom (CAP) <i>Shuttered TV/SAT movable plug for frequencies up to 2400 MHz F male connector - supplied with n.1 plastic connector (CAP)</i>	50	50
 TVFST		<b>TVFST</b> Univerzalna vezica za fiksiranje kablova/cevi prečnika 0,5÷32 mm <i>Universal band for 0,5÷32 mm cables/ducts fixing</i>	100	100
 TVPZ		<b>TVPZ</b> Klješta za montažu plastičnih kapičica CAP - olakšava postavljanje i skidanje kapičica CAP sa ženskih F konektora <i>Pliers for CAP fixing operations - it simplifies the operations of the CAP inserting and pulling out on F female connectors</i>	1	10

## CAP

### POVEZIVANJE CONNECTION

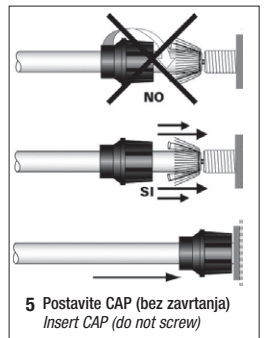
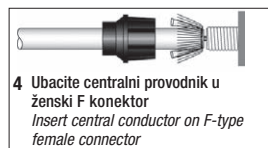
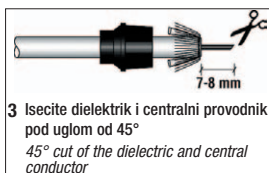
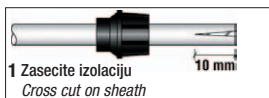

### Izvlačenje EXTRACTION

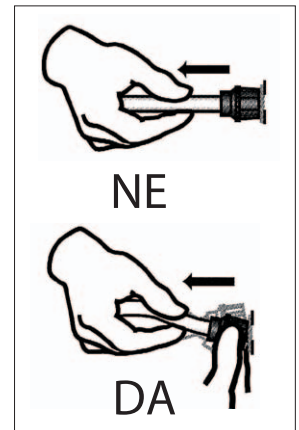

Za raspoloživost kontaktirajte Ave distributere  
For availability please contact sales dept.



Dostupni dok se ne rasprodaju zalihe  
Available until stock out







Proizvod za pravougaone kutije britanskog standarda  
Product for British standard rectangular box



Proizvod za izvoz  
For Export only

## Signalni konektori Connectors

	Opis	Description	Info	€
 <b>CBNCF</b>	<b>CBNCF</b> AVE BNC ženski konektor - dolazni priključak preko muškog F konektora - za video signal niskih frekvencija - najčešća primena za povezivanje CCTV uređaja i dekodera - u kompletu sa plastičnom kapičom (CAP) za povezivanje kablova - može se postaviti na adapter 44..029SC <i>AVE BNC female connector - input connection through F-type male connector - for low frequency video connections - typical use for TVCC and decoder connections - supplied with (CAP) plastic connector - installable on adaptor code 44..029SC</i>		5	5
 <b>CRCAF</b>	<b>CRCAF</b> AVE RCA ženski konektor - dolazni priključak preko muškog F konektora - za audio signal niskih frekvencija - najčešća primena za povezivanje zvučnika - u kompletu sa plastičnom kapičom (CAP) za povezivanje kablova - može se postaviti na adapter 44..029SC <i>AVE RCA female connector - input connection through F-type male connector - for low frequency audio connections - typical use for loudspeaker connections - supplied with (CAP) plastic connector - installable on adaptor code 44..029SC</i>		5	5
 <b>CRJ11T</b>	<b>CRJ11T</b> AVE RJ11 konektor (4 kontakta) - žabice za povezivanje kablova bez alata - može se postaviti na adapter 44..029SC <i>AVE RJ11 connector (4 contacts) - insulation piercing terminals with rapid wiring - installable on adaptor code 44..029SC</i>		5	5
 <b>CRJ45C5E</b>	<b>CRJ45C5E</b> AVE RJ45 priključnica kategorije 5 e - neoklopljena - žabice za spajanje kablova uz pomoć alata - brzo kabliranje pomoću priloženog alata - univerzalno kabliranje T568A i T568B - 8 kontakata - može se postaviti na adapter 44..029SC <i>AVE RJ45 category 5 enhanced connector - not shuttered - insulation piercing terminals - supplied with accessory for rapid wiring - T568A and T568B universal wiring - 8 contacts - installable on adaptor code 44..029SC</i>		5	5



## Signalni konektori Ave Ave Connectors

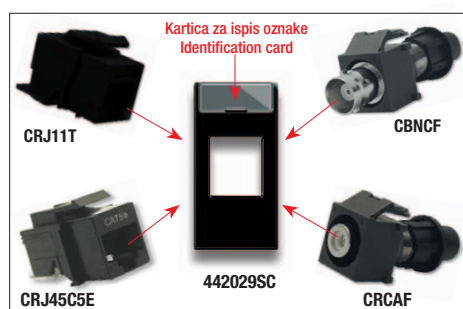

Svi tipovi konektora mogu se instalirati na isti tip adaptera - kod 442029SC  
All the connectors can be installed on the adapter code 442029SC

Instalacija konektora u adapter  
Connector clipping to the adapter

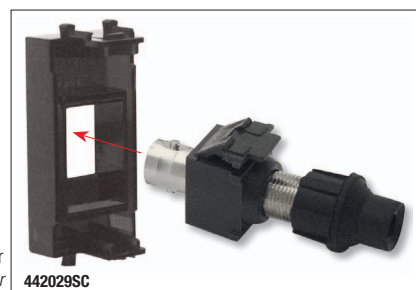









# Serija LIFE Touch - ALLUMIA Touch

LIFE Touch - ALLUMIA Touch series



Automatski magnetotermički osigurači 120-230V~  
MCBs 120-230V~







92

Life 44	Allumia	Opis	Description	Info	€
		■ 442052X6	■ 443052X6	1	10
442052X6	443052X6	Automatski magnetotermički osigurači 1P+N 6A 120-230V~ prekidni kapacitet 1,5kA disipacija 1,2W - 1 modul <i>MCB 1P+N 6A 120-230V~ b.c. 1,5kA - dissipated power 1,2W - 1 module</i>			
		■ 442052X10	■ 443052X10	1	10
442052X10	443052X10	Automatski magnetotermički osigurači 1P+N 10A 120-230V~ prekidni kapacitet 3kA disipacija 1W - 1 modul <i>MCB 1P+N 10A 120-230V~ b.c. 3kA - dissipated power 1W - 1 module</i>			
		■ 442052X16	■ 443052X16	1	10
442052X16	443052X16	Automatski magnetotermički osigurači 1P+N 16A 120-230V~ prekidni kapacitet 3kA disipacija 2,1W - 1 modul <i>MCB 1P+N 16A 120-230V~ b.c. 3kA - dissipated power 2,1W - 1 module</i>			

**Napomena:** Osigurači sa C krivinom prekidanja  
**Note:** MCB type C

U skladu sa normom IEC 60898  
*In conformity with IEC 60898 standard*

## Diferencijalna (FID) sklopka sa automatskim magnetotermičkim osiguračem 120-230V~ RCBOs120-230V~

Life 44	Allumia	Opis	Description	Info	€
		■ 442062X6	■ 443062X6	1	6
442062X6	443062X6	Diferencijalna (FID) sklopka sa automatskim magnetotermičkim osiguračem 1P+N 6A 120-230V~ $I_{\Delta n}$ 10mA prekidni kapacitet 1,5kA - disipacija 1,3W - 2 modula <i>RCBO 1P+N 6A 120-230V~ <math>I_{\Delta n}</math> 10mA b.c. 1,5kA - dissipated power 1,3W - 2 modules</i>			
		■ 442062X10	■ 443062X10	1	6
442062X10	443062X10	Diferencijalna (FID) sklopka sa automatskim magnetotermičkim osiguračem 1P+N 10A 120-230V~ $I_{\Delta n}$ 10mA prekidni kapacitet 3kA - disipacija 1,1W - 2 modula <i>RCBO 1P+N 10A 120-230V~ <math>I_{\Delta n}</math> 10mA b.c. 3kA - dissipated power 1,1W - 2 modules</i>			
		■ 442062X16	■ 443062X16	1	6
442062X16	443062X16	Diferencijalna (FID) sklopka sa automatskim magnetotermičkim osiguračem 1P+N 16A 120-230V~ $I_{\Delta n}$ 10mA prekidni kapacitet 3kA - disipacija 2,5W - 2 modula <i>RCBO 1P+N 16A 120-230V~ <math>I_{\Delta n}</math> 10mA b.c. 3kA - dissipated power 2,5W - 2 modules</i>			

**Napomena:** ✓ signalizacija mrežnog napajanja i zatvorenog kontakta preko zelene LED indikatorske lampice  
✓ osigurači sa C krivinom prekidanja - diferencijalne sklopke tipa A

**Notes:** ✓ frontal signal of power supply and closed contact through a green led  
✓ MCB type C - RCBO type A

U skladu sa normom IEC 61009  
*In conformity with IEC 61009 standard*



Za raspoloživost kontaktirajte  
Ave distributere  
For availability please contact  
sales dept.



Dostupni dok se ne  
rasprodaju zalihe  
Available until stock out





Proizvod za pravougaone  
kutije britanskog standarda  
Product for British standard  
rectangular box



Proizvod za  
izvoz  
For Export  
only

## Diferencijalna (FID) sklopka 120-230V~ RCCBs 120-230V~





Life 44	Allumia	Opis	Description	Info	€
		<p>■ 442062X16/30MA ■ 443062X16/30MA</p> <p>Diferencijalna (FID) sklopka 2P 16A 120-230V~ I<sub>Δn</sub> 30mA - disipacija 2,5W - 2 modula</p> <p>RCCB 2P 16A 120-230V~ I<sub>Δn</sub> 30mA - dissipated power 2,5W - 2 modules</p>		<p>na upit upon request</p>	1 6
442062X16/30MA	443062X16/30MA	<p><b>Napomena:</b> ✓ signalizacija mrežnog napajanja i zatvorenog kontakta preko zelene LED indikatorske lampice ✓ Diferencijalne sklopke tip A</p> <p><b>Notes:</b> ✓ frontal signal of power supply and closed contact through a green led ✓ RCBO type A</p>			
<p>U skladu sa normom IEC 61008 In conformity with IEC 61008 standard</p>					

93



Sistema 45

## Nosači osigurača 250V~ Fuse Holders 250V~

Life 44	Allumia	Opis	Description	Info	€
		<p>■ 442007 ■ 443007</p> <p>Nosač minijaturnih osigurača 1P 16A - za osigurače Ø 5x20 mm - isporučuje se bez osigurača - 1 modul</p> <p>Fuse holder for miniature fuses 1P 16A - for fuses Ø 5x20 mm - supplied without fuse - 1 module</p>			1 10
442007	443007	<p>■ 442007/13A ■ 443007/13A</p> <p>Nosač osigurača BS1362 1P 13A - za osigurače Ø 6,3x28 mm - isporučuje se u kompletu sa osiguračem - 1 modul</p> <p>Fuse holder for BS1362 fuse 1P 13A - for fuses Ø 6,3x28 mm - supplied with fuse - 1 module</p>			1 10
		442007/13A	443007/13A		





# Serija LIFE Touch - ALLUMIA Touch

LIFE Touch - ALLUMIA Touch series



Relaj za pozivni SOS sistem  
Relays

94

Life 44

Allumia

Opis

Description

Info

€



442087C



443087C

■ 442087C

■ 443087C

1 6

Statički bistabilni relej (tipa Flip-Flop SR) 12Vac/cc za pozivne sisteme - 2 izlaza: za svetlosnu signalizaciju (za stalnu ili koja treperi) i za zvučnu signalizaciju (kontinuiran zvuk ili u intervalima od 3 sekunde do 1 minuta) - aktiviranje i resetovanje alarma sa više udaljenih lokacija pomoću paralelno vezanih NO tastera - 1 modul

Static bistable relay (type Flip-Flop SR) 12Vac/dc for call systems - 2 outputs: for visual signals (flashing or fixed) and acoustic signals (continuous sound or at intervals of 3 seconds to 1 minute) - activated and silenced from various points using normal NO push buttons connected in parallel - 1 module

**Napomena:** za pravilan rad releja neophodno je obezbediti transformator 12Vac ili napajanje 12Vdc odgovarajuće dimenzionisano

**Note:** for the proper functioning of the relay it is necessary to provide a transformer 12Vac or a power supply 12Vdc appropriately sized

Šema povezivanja 442087C

Connection Diagram 442087C

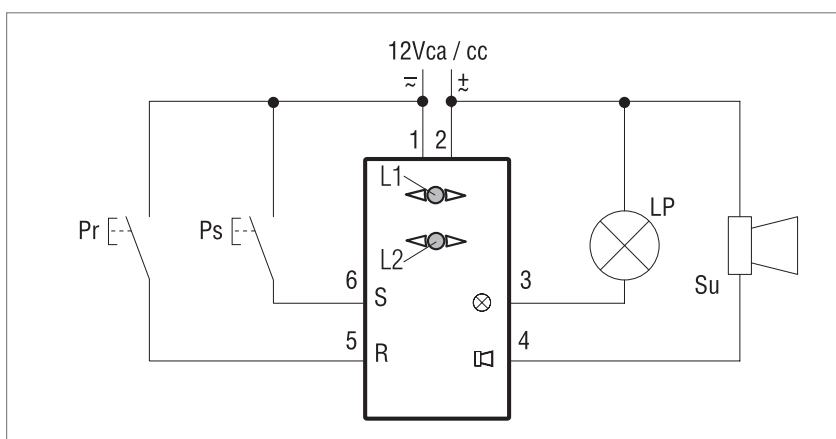

## Pozivni sistem-upotreba releja za pozivni sistem Call Relay – Call System

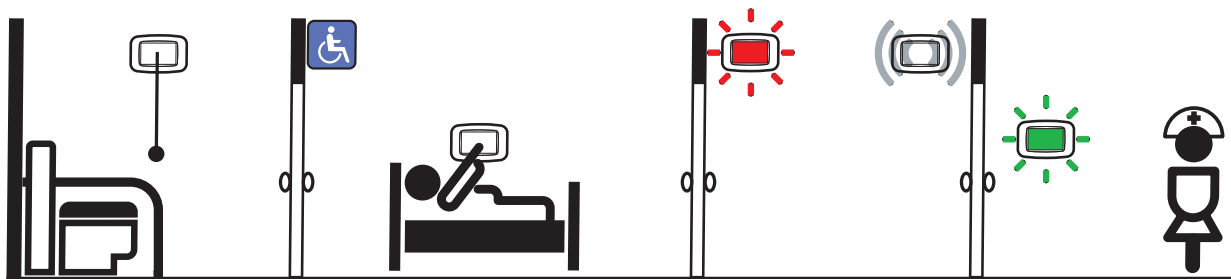

Pritiskom na taster, pacijent vrši poziv. Relaj aktivira svetlosnu i zvučnu signalizaciju u hodniku kao i svetlosnu signalizaciju na recepciji koja odgovara borju poziva  
By pressing a push button the patient makes a call. The relay activates the visual and sound signals in the corridor and the visual signal at reception corresponding to the caller's number



Medicinska sestra po dolasku u sobu pacijenta može resetovati alarm pritiskom na odgovarajući reset taster, poništavajući tako optičku i akustičnu signalizaciju.  
The nurse is summoned to the patient's room and can reset by pressing the push button in the room, cancelling the visual and sound signals.



Za raspoloživost kontaktirajte Ave distributere  
For availability please contact sales dept.



Dostupni dok se ne rasprodaju zalihe  
Available until stock out









Proizvod za pravougaone kutije britanskog standarda  
Product for British standard rectangular box



Proizvod za izvoz  
For Export only

## Elektromehanička zvona i zujalice

### Bells / buzzers

Life 44	Allumia	Opis	Description	Info	€
		■ 442028	■ 443028		1 10
442028	443028	Zvono 12V~ 8VA (SELV) - 1 modul			
442029	443029	Ringing Bell 12V~ 8VA (SELV) - 1 module			
		■ 442029	■ 443029		1 10
		Zvono 230V~ - 1 modul			
		Ringing bell 230V~ - 1 module			
		■ 442030	■ 443030		1 10
442030	443030	Zujalica 12V~ 8VA (SELV) - 1 modul			
442031	443031	Buzzer 12V~ 8VA (SELV) - 1 module			
		■ 442031	■ 443031		1 10
		Zujalica 230V~ - 1 modul			
		Buzzer 230V~ - 1 module			





95



Sistema 45

## Elektronska zvona

### Electronic bells

Life 44	Allumia	Opis	Description	Info	€
		■ 442081	■ 443081		1 10
442081	443081	Pomoćni signalizator alarma sa mogućnošću podešavanja tajmera zvona u intervalu 5-12s u funkciji napona napajanja - napajanje 12-24 Vcac/dc - mogućnost podešavanja ineziteta zvuka - zvučni pritisak 86dB na 1m - LED signalizacija sa prednje strane - 1 modula			
		<i>Auxiliary alarm signal with the possibility of setting a timer to ring for 5-12s depending on input voltage - input 12-24 Vac/dc - it is possible to adjust the sound volume - acoustic pressure 86 dB at 1m - front signalling led - 1 mod.</i>			
		■ 442083	■ 443083		1 6
442083	443083	Trotonsko elektronsko zvono - napajanje 12 Vac/dc - mogućnost izbora jednog od šest različitih melodija - mogućnost podešavanja inteziteta zvuka sa prednje strane - LED signalizacija sa prednje strane - zvučni pritisak 71-76 dB na 1m u zavisnosti od odabrane vrste tona - 2 modula			
		<i>Three tone electronic bell - 12 Vac/dc power supply - possibility to choose one out of six tones - frontal sound regulation - frontal signalling led - acoustic pressure 71-76 dB at 1m according to the sound activated - 2 modules</i>			
		■ AF442099			1 1
AF442099		Pomoćna sirena za protivprovalne sisteme ili zvučnu signalizaciju - napajanje 12Vdc - mogućnost podešavanja 2 nivoa jačine zvuka - mogućnost izbora jednog od tri tona - zvučni pritisak 90dB na 3m - isporučuje se u kompletu sa nalepnicom ALARM - 2 modula			
		<i>Indoor siren for burglar alarm systems or acoustical device - 12 Vdc - power supply - possibility to set two different levels of acoustic intensity - possibility to choose among three different acoustic sounds - acoustic pressure 90 dB at 3m - supplied with sticky label with "ALARM" writing - 2 modules</i>			



# Serija LIFE Touch - ALLUMIA Touch

LIFE Touch - ALLUMIA Touch series



## Stepenišna svetiljka Step marker lights

96

Life 44	Allumia	Opis	Description	Info	€
		■ 442070B/2	■ 443070B/2	1	6
442070B/2	443070B/2	Stepenišna svetiljka - napajanje 12-24 Vac/dc ili 230 V~ - LED lampica plave boje visoke efikasnosti - 2 modula Step marker light - input 12-24 Vac/dc or 230 V~ - blue led, high efficiency - 2 modules.			
		■ 442070W/2	■ 443070W/2	1	6
442070W/2	443070W/2	Stepenišna svetiljka - napajanje 12-24 Vac/dc ili 230 V~ - LED lampica bele boje visoke efikasnosti - 2 modula Step marker light - input 12-24 Vac/dc or 230 V~ - white high efficiency led - 2 modules			

## Prenosiva baterijska svetiljka Removable portable lights

Life 44	Allumia	Descrizione	Description	Info	€
		■ 442086	■ 443086	1	1
442086	443086	Prenosiva baterijska svetiljka sa bazom za punjenje - u kompletu sa punjivom baterijom koja se može zameniti - svetiljka: LED bele boje visoke efikasnosti - prekidač sa prednje strane za isključivanje u slučaju nestanka mrežnog napajanja - vreme punjenja 36 sati - automonija oko 3 sata - napajanje 110÷230V~ - 2 Anti black out removable portable light - with recharging base - with interchangeable and rechargeable batteries - lamp: high efficiency white led - front switch in case of power failure - 36 hours recharge time - 3 hours endurance - 110÷230V~ power supply - 2 modules			
		45786B		1	1
45786B		Rezervna baterija (4x1,2)V - 80mAh, za uređaje 442086 i 443086 Spare battery for 442086 and 443086 (4x1,2)V - 80mAh			

## Prenosiva svetiljka Removable lights

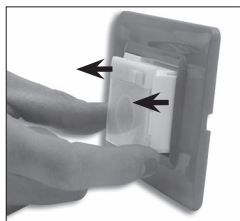
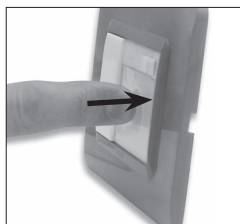

Izvlačenje svetiljke:  
pritisnuti sa prednje strane  
Light removal:  
push on the front

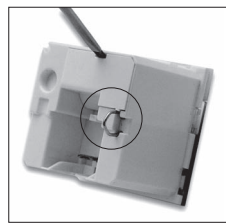

Kačenje svetiljke  
Light clipping hook

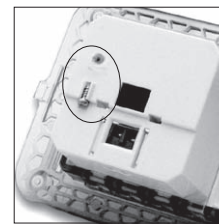

Šraf za blokiranje vađenja  
svetiljke  
Light anti-removal screw

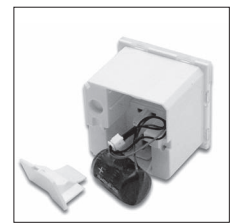

Zamena baterije  
Battery replacement



Za raspoloživost kontaktirajte  
Ave distributere  
For availability please contact  
sales dept.



Dostupni dok se ne  
rasprodaju zalihe  
Available until stock out







Proizvod za pravougaone  
kutije britanskog standarda  
Product for British standard  
rectangular box

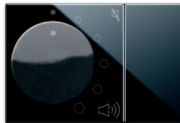

Proizvod za  
izvoz  
For Export  
only

## Sistem ozvučenja Sound diffusion

Life 44	Allumia	Opis	Description	Info	€
		<p>■ <b>442AP01</b></p> <p>Zvučnik - impedansa 8 Ohm - snaga 5W - zaštita od preopterećenja sa signalizacijom pomoću LED lampice - isporučuje se u kompletu sa dva spoljašnja okvira bele boje Ral 9010 koji se koriste sa maskama 6 (3+3) modula: jedan je za maske Zama/Personal 44 (44P933... - 44P033...) a drugi je za maske Vera 44 (44PV33...-44PA33...-44PL33...). Okvir se mora postaviti na odgovarajuću masku nakon skidanja originalnog okvira sa prečkom po sredini koja je isporučena sa maskom - može se koristiti i hromirani okvir 44CRV33CR/AP (za maske Vera 44) ili 44CR33CR/AP (za maske Zama/Personal 44) - instalacija sa armaturom 44A33 u ugradnu kutiju BL02P</p> <p><i>Loudspeaker - 8 Ohm impedance - 5W power - overload protection with LED indication - supplied with inner frames white Ral 9010 for use with plates 6(3+3) modules: one inner frame for Zama/Personal 44 (44P933... - 44P033...) and one for Vera 44 plates (44PV33...-44PA33...-44PL33...). The inner frame must be installed after removing the original one supplied with the plate with the central crossbar - possibility to use chrome inner frame 44CRV33CR/AP (for Vera44 plates) or 44CR33CR/AP (for Zama/Personal44 plates) - installation with 44A33 frame in BL02P flush mounted box</i></p>		1	1
		<p>■ <b>442DS01</b>      ■ <b>443DS01</b></p> <p>Mono regulator nivoa zvuka za zvučnike - omogućava podešavanje nivoa zvuka svakog pojedinačnog zvučnika (levi ili desni kanal) bez vršenja uticaja na druge zvučnike koji su instalirani na istom sistemu - podešavanje u 6 pozicija: OFF, 1, 2, 3, 4, 5 - 2 modula</p> <p><i>Mono volume controller for loudspeakers - It allows the control of an individual loudspeaker (left or right channel) with no interference on the volume of other loudspeakers installed in the same plant - regulation with 6 positions (OFF, 1, 2, 3, 4, 5) - 2 modules</i></p>		1	1
		<p>■ <b>442DS02</b>      ■ <b>443DS02</b></p> <p>Stereo regulator nivoa zvuka za zvučnike - omogućava istovremeno podešavanje nivoa zvuka jednog para zvučnika (desni i levi kanal) bez vršenja uticaja na druge parove zvučnika koji su instalirani na istom sistemu - podešavanje u 6 pozicija: OFF, 1, 2, 3, 4, 5 - u kompletu sa armaturom za kutiju 2503MG - 3 modula</p> <p><i>Stereo volume controller for loudspeakers - It allows simultaneous control of a pair of loudspeakers (left and right channels) with no interference on the volume of other pairs of loudspeakers installed in the same plant. Regulation with 6 positions (OFF, 1, 2, 3, 4, 5) - complete with frame for 2503MG box - 3 modules</i></p>		1	1



Sistema 45

### Primer upotrebe sistema ozvučenja    Sound diffusion application example

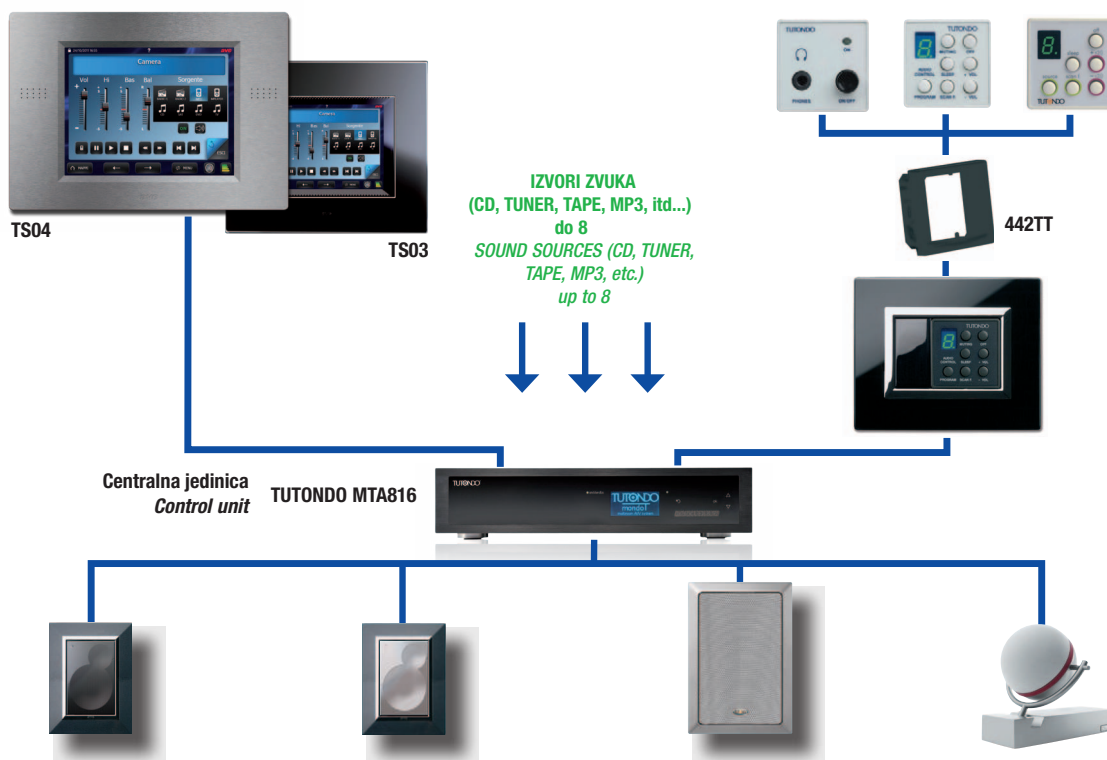

Min. pakovanje kom.  
Min. Packaging pcs

Stand. pakovanje kom.  
Std. Packaging pcs



# Serija LIFE Touch - ALLUMIA Touch

LIFE Touch - ALLUMIA Touch series



Optička signalizacija  
Optical signals

98



442037RS 442037TR 442037VE



442067 442076 442076VE

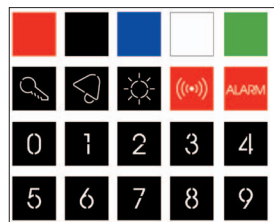

ETI20

Opis	Description	Info	€
442037RS	Nosač lampice sa crvenim difuzorom - u kompletu sa izmenljivim karticama sa simbolima - 1 modul <i>Lampholder with red diffuser - supplied with interchangeable labels and insert lenses - 1 module</i>	1	10
442037TR	Nosač lampice sa providnim difuzorom - u kompletu sa izmenljivim karticama sa simbolima - 1 modul <i>Lampholder with transparent diffuser - supplied with interchangeable labels and insert lenses - 1 module</i>	1	10
442037VE	Nosač lampice sa zelenim difuzorom - u kompletu sa izmenljivim karticama sa simbolima - 1 modul <i>Lampholder with green diffuser - supplied with interchangeable labels and insert lenses - 1 module</i>	1	10
442067	Dvostruki nosač lampice sa crvenim/zelenim difuzorom - u kompletu sa izmenljivim karticama sa simbolima - 1 modul <i>Twin lampholder with red/green diffuser - supplied with interchangeable insert lenses - 1 module</i>	1	10
442076	Ispučeni nosač lampice (ispred vrata) sa crvenim difuzorom - za lampice 10x28 mm sa grlom E10 230V~ 3W max - 2 modula <i>Prominent lampholder (outside door) with red diffuser - for E10 10x28 mm 230V~ 3W max lamps - 2 modules</i>	1	6
442076VE	Ispučeni nosač lampice (ispred vrata) sa zelenim difuzorom - za lampice 10x28 mm sa grlom E10 230V~ 3W max - 2 modula <i>Prominent lampholder (outside door) with green diffuser - for E10 10x28 mm 230V~ 3W max lamps - 2 modules</i>	1	6
ETI20	Komplet od 20 izmenljivih kartica sa simbolima za nosače lampica - različiti stil i simboli <i>Set of 20 interchangeable labels for lampholders - different words and symbols</i>	1	1

**Novo**

**Napomena:** nosači lampica isporučuju se bez signalnih lampica

**Note:** lampholders are supplied without signalling lamp

## Signalne lampice Optical Signals

### Postupak montaže

### Assembly Procedure

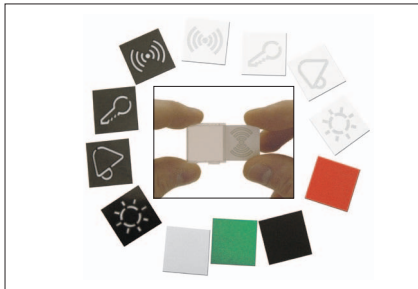

1. Odaberite željenu karticu i postavite je sa zadnje strane difuzora  
*Select the label and place it in the back of the diffuser*

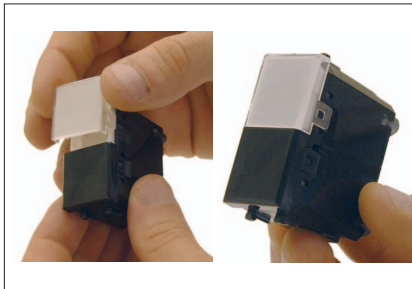

2. Postavite difuzor na njegovu bazu  
*Place the diffuser on its base*

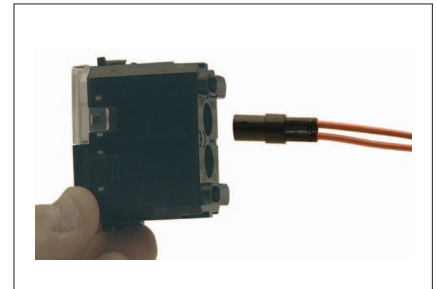

3. Sa zadnje strane postavite signalnu lampicu  
*Introduce the signalling lamp from the back*

### Nekoliko primera lampica

### A few Examples of customization

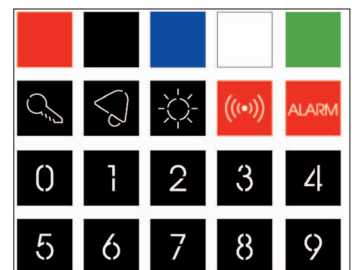

ETI20 Komplet od 20 izmenljivih kartica  
ETI20 Set of 20 interchangeable labels



Za raspoloživost kontaktirajte Ave distributere  
For availability please contact sales dept.



Dostupni dok se ne rasprodaju zalihe  
Available until stock out



Proizvod za pravougaone kutije britanskog standarda  
Product for British standard rectangular box



Proizvod za izvoz  
For Export only

## Signalne lampice E10 E10 signalling lamps





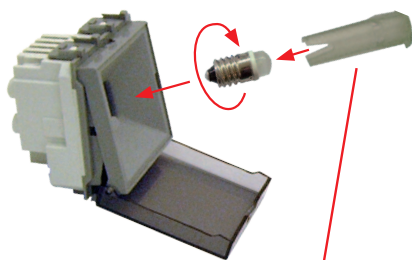

Opis	Description	Info	€
 0212LDW/E10 0212LDW/E10HI 0230LDW/E10	<b>0212LDW/E10</b> LED lampica 12V~ E10 10x22 mm - bele boje - koristi se sa tasterom sa pozadinskim osvetljenjem za karticu sa imenom 441005TP/2 i 442005TP/2 <i>LED lamp 12V~ E10 10x22 mm - white colour - to be used with name tag code 441005TP/2 and 442005TP/2</i>	10	10
<b>0212LDW/E10HI</b> LED lampica visokog inteziteta 12V~ E10 10x22 mm - bele boje - koristi se sa ispuštenim nosačem lampica 442076 <i>High intensity led lamp 12V~ E10 10x22 mm - white colour - to be used with prominent lampholder code 442076</i>	10	10	
<b>0230LDW/E10</b> LED lampica 230V~ E10 10x22 mm - bele boje - koristi se sa tasterom sa pozadinskim osvetljenjem za karticu sa imenom 441005TP/2 i 442005TP/2 ili sa ispuštenim nosačem lampica 442076 <i>LED lamp 230V~ E10 10x22 mm - white colour - to be used with name tag push buttons code 441005TP/2 and 442005TP/2 or with prominent lampholder code 442076</i>	10	10	

### Instalacija signalne lampice E10 E10 signalling lamp installation



Dotatna oprema u kompletu sa lampicom  
Accessory supplied with the lamps

## Signalne lampice Signalling lamps

Opis	Description	Info	€
 0224 <b>0212LDW</b> <b>0230LDW</b>	<b>0212LDB</b> LED lampica 12-24Vac/dc niske potrošnje - plave boje <i>Low consumption 12-24Vac/dc led lamp - blue colour</i>	Preporučuje se za komande, utičnice i nosače lampica sa simbolima <i>It is recommended for controls, sockets and lampholders with symbols</i>	10 10
 <b>0212LDR</b> <b>0230LDR</b>	<b>0212LDW</b> LED lampica 12-24Vac/dc niske potrošnje - bele boje <i>Low consumption 12-24Vac/dc led lamp - white colour</i>	Preporučuje se za nosače lampica <i>It is recommended for lampholders</i>	10 10
 <b>0212LDR</b> <b>0230LDR</b>	<b>0212LDR</b> LED lampica 12-24Vac/dc niske potrošnje - crvene boje <i>Low consumption 12-24Vac/dc led lamp - red colour</i>	Preporučuje se za crvene nosače lampica <i>It is recommended for red lampholders</i>	10 10
 <b>0212LDB</b> <b>0230LDB</b>	<b>0230LDB</b> LED lampica 230V~ niske potrošnje - plave boje <i>Low consumption 230V~ led lamp - blue colour</i>	Preporučuje se za komande, utičnice i nosače lampica <i>It is recommended for controls, sockets and lampholders with symbols</i>	10 10
 <b>0212LDB</b> <b>0230LDB</b>	<b>0230LDW</b> LED lampica 230V~ niske potrošnje - bele boje <i>Low consumption 230V~ led lamp - white colour</i>	Preporučuje se za nosače lampica <i>It is recommended for lampholders</i>	10 10
 <b>0212LDB</b> <b>0230LDB</b>	<b>0230LDR</b> LED lampica 230V~ niske potrošnje - crvene boje <i>Low consumption 230V~ led lamp - red colour</i>	Preporučuje se za nosače lampica <i>It is recommended for red lampholders</i>	10 10

## Primer upotrebe indikatorne lampice Signalling lamps application examples

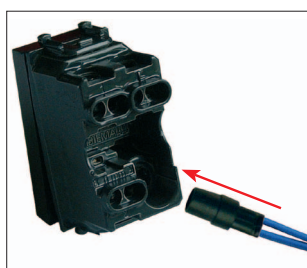

### Šuko utičnice Schuko Sockets

Predlaže se upotreba LED lampice plave boje (0230LDB)  
*It is recommended the use of blue color led lamp (code 0230LDB)*

### Komande Controls

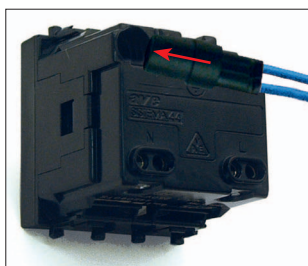

### Nosači lampica Optical Signals

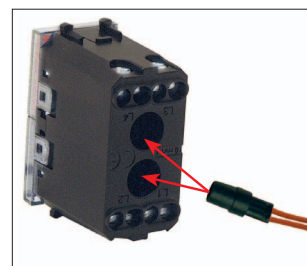











# Serija LIFE Touch - ALLUMIA Touch

LIFE Touch - ALLUMIA Touch series



Dimmer za regulaciju inteziteta svetla  
Dimmer for lighting controls



100

Life 44	Allumia	Opis	Description	Info	€
 442048	 443048	■ 442048	■ 443048 Dimmer za svetlo 230V~ (127 V~) 50-60Hz za rezistivna opterećenja (inkadescentne i halogene svetiljke) 100÷500W (60÷300W) - regulacija pomoću rotacionog potenciometra - LED indikator za identifikaciju u mraku - 1 modul <i>Dimmer 230V~ (127 V~) 50-60Hz for resistive loads (incandescent and halogen lamps) 100÷500W (60÷300W) - regulation with rotary potentiometer - led for identification in the dark - 1 module</i>	1	6
 442048D	 443048D	■ 442048D	■ 443048D Dimmer za svetlo 230V~ 50-60Hz za rezistivna opterećenja (inadescentne i halogene svetiljke) 40÷300W - upravljanje pomoću ugrađenog naizmeničnog prekidača i pomoću rotacionog potenciometra - LED indikator za identifikaciju u mraku - smanjena dubina - kontakti sa bočne strane - 1 modul <i>Dimmer 230V~ 50-60Hz for resistive loads (incandescent and halogen lamps) 40÷300W - control with built-in two-way switch and regulation with rotary potentiometer - led for identification in the dark - reduced depth - side terminal screws - 1 module</i>	1	6
 442048U 442048L	 443048U 443048L	■ 442048U	■ 443048U Dimmer za svetlo 230V~ 50-60Hz za rezistivna i induktivna opterećenja (inadescentne i halogene svetiljke, feromagnetne transformatore za halogene svetiljke niskog napona) 60÷500W - upravljanje i regulacija pomoću ugrađenog tastera ili sa više udaljenih lokacija preko NO tastera - LED indikator za identifikaciju u mraku - 1 modul <i>Dimmer 230V~ 50-60Hz for resistive and inductive loads (incandescent and halogen lamps, ferromagnetic transformers for low voltage halogen lights) 60÷500W controls and regulation with built-in push-button or from more points with normal NO buttons - led for identification in the dark - 1 module</i>	1	6
 442048AE	 443048AE	■ 442048L	■ 443048L Dimmer za svetlo 230V~ 50-60Hz za kapacitivne elektronske transformatore 40-250VA - upravljanje i regulacija pomoću ugrađenog tastera ili sa više udaljenih lokacija preko standardnih NO tastera - LED indikator za identifikaciju u mraku - 1 modul <i>Dimmer 230V~ 50-60Hz for electronic capacitive transformers 40-250VA - control and regulation through built-in push button or from more points through normal push buttons NO- led for identification in the dark - 1 module</i>	1	6
		■ 442048AE	■ 443048AE Dimmer za elektronska napajanja sa ulazom 1÷10V (balasti, fluorescentne svetiljke) - izlaz 4A/250V~ - 2 modula <i>Dimmer for electronic power units input 1÷10V - contact 4A/250V~ - 1 module</i>	<b>Novo</b>	1 6

## Dimeri za regulaciju brzine ventilatora fan-coil-a Dimmers for ceiling fan

Life 44	Allumia	Opis	Description	Info	€
 442048AA	 443048AA	■ 442048AA	■ 443048AA Dimmer za ventilator sa 3 brzine (+isključivanje) 55÷80VA 230V~ 50-60Hz-komanda preko ugrađenog tastera ili sa više udaljenih lokacija pomoću standardnih NO tastera - tehnologija koja garantuje apsolutno "nečujni" rad - LED indikator za identifikaciju u mraku - 1 modul <i>3-speed push button dimmer (+ switch off) 55÷80VA 230V~ 50-60Hz- control with built-in push-button or from more points with normal NO buttons - technology guaranteeing absolute "silence" - led for identification in the dark - 1 module</i>	1	6

## Programabilni tajmer 120-230V~ Programmable time switches 120-230V~

Life 44	Allumia	Opis	Description	Info	€
 442023GSR	 443023GSR	■ 442023GSR	■ 443023GSR Elektronski programabilni tajmer - programiranje na dnevnom/nedeljnom /godišnjem nivou - 1 kanal - prenosiv - 1 naizmenični relejni izlaz 8A (2A induktivno) 230V~ - napajanje 120/230V~ 50-60Hz - 2 modula <i>Electronic programmable time switch 24 hours / 7 days / 1 year 1 channel - removable - 1 output through relay by means of a change-over contact 8A (2A Inductive) 230V~ 50-60Hz - power supply 120/230V~ - 2 modules</i>	1	1

**Napomena:** za primer primene vidi str. 127  
**Note:** see page 127 for application examples



Za raspoloživost kontaktirajte Ave distributere  
For availability please contact sales dept.



Dostupni dok se ne rasprodaju zalihe  
Available until stock out



Proizvod za pravougaone kutije britanskog standarda  
Product for British standard rectangular box







Proizvod za izvoz  
For Export only

**MAKSIMALNE PERFORMANSE u cijlu UŠTEDE ENERGIJE:**



- \* MINIMALNA DIFERENCIALNA TEMPERATURA: DETEKTOVANJE MINIMALNIH VARIJACIJA U TEMPERATURI RADI IZBEGAVANJA VELIKIH OSCILACIJA U SOBNOJ TEMPERATURI
- \* MINIMALNI RADNI OFFSET, ŠTO PODRAZUMJEVA MINIMALNE VARIJACIJE U PODEŠENOJ TEMPERATURI IZMEĐU REŽIMA RADA NEOPTEREĆENOG TERMOSTATA I MAKSIMALNO OPTEREĆENOG TERMOSTATA

**Termostati  
Thermostats****MAXIMUM PERFORMANCE for ENERGY SAVING:**



- \* MINIMUM THERMIC DIFFERENTIAL: TEMPERATURE VARIATIONS ARE DETECTED IN ORDER TO AVOID EXTREME ROOM TEMPERATURE OSCILLATIONS
- \* MINIMIZED ON-DUTY OFFSET, AS TO SAY THE VARIATION OF THE ADJUSTED TEMPERATURE BETWEEN NO LOAD AND FULL LOAD OPERATING CONDITIONS.

Life 44	Allumia	Opis	Description	Info	€
		■ 442085	■ 443085 Elektronski termostat sa rotacionim potencijetrom za kontrolu temperature prostorije - izlaz sa naizmeničnim kontaktom NO+NC 5A (2A induktivno) 230V~ - opseg regulacije temperature od 5°C do 30°C - napajanje 230V~ 50-60 Hz - 2 modula <i>Electronic thermostat with rotary knob for room temperature control - exit with switching contact NO+NC 5A (2A inductive) - temperature range from 5 °C to 30 °C - 230V~ power supply - 50-60 Hz - 2 modules</i>	H.P. TECHNOLOGY	1 1
442085	443085	■ 442085SW	■ 443085SW Elektronski leto/zima termostat sa displejem i pozadinskim osvetljenjem za kontrolu temperature prostorije (grejanje i hlađenje) - izlaz sa naizmeničnim kontaktima NO+NC 2A 230V~ opseg regulacije temperature od 0°C do 35°C - dugmad za kontrolu sa pozadinskim osvetljenjem - ulaz za aktiviranje sa udaljene lokacije i ulaz za prinudnu redukciju temperature - napajanje 230V~ 50-60 Hz - 2 modula <i>Electronic winter/summer thermostat with backlit display for room temperature control (heating and air-conditioning) - exit with switching contacts NO+NC 2A 230V~ - temperature range from 0 °C to 35 °C - backlit controls - input for remote activation and input for forcing at reduced temperature - 230V~ power supply - 50-60 Hz - 2 modules</i>	H.P. TECHNOLOGY	1 1
		442085SW	443085SW		

**Programabilni termostati napajani iz mreže Chronothermostats power line supplied**

Life 44	Allumia	Opis	Description	Info	€
		■ 442CRT	■ 443CRT Programabilni elektronski termostat sa displejem i pozadinskim osvetljenjem za kontrolu temperature prostorije (grejanje i hlađenje) - programiranje na dnevnom/nedeljnom nivou - prenosni - izlaz sa naizmeničnim kontaktima NO+NC 3A 230V~ - opseg podešavanja temperature od 0°C do 35°C - programiranje bazirano na tri temperature (0°C ÷ 35°C) korekcija izmerene temperature preko offset funkcije +/-5°C - programiranje u koracima od 30 minuta - antifriz funkcija - pozadinski osvetljenja kontrolna dugmad - ulaz za kontrolu sa udaljene lokacije - automatsko prebacivanje na zimsko/letnje računanje vremena - višezječni meni - napajanje 120~ / 230V~ 50-60 Hz - 2 modula <i>Electronic winter/summer thermostat with backlit display for room temperature control (heating and air-conditioning) - daily/weekly programming - removable - exit with switching contacts NO+NC 3A 230V~ - programmable based on three temperature levels (0 °C ÷ 35 °C) - adjustment of temperature measured with offset +/-5 °C - setting programs three temperatures (0 °C ÷ 35 °C) - programming with of 30 minutes steps - pump anti-seizing function - backlit controls - input for remote control - menu with multilingual text guide - automatic switch to daylight saving/solar time - 120~/230V~ power supply - 50-60 Hz - 2 modules</i>	H.P. TECHNOLOGY	1 1
442CRT	443CRT				

**Programabilni termostati napajani iz baterije Chronothermostat battery power supplied**

Cod. Code	Opis	Description	Info	€
	■ CRONOTC2B	■ CRONOTC3B Nadgradni programabilni elektronski termostat sa ekranom na dodir - veliki displej sa pozadinskim osvetljenjem za kontrolu temperature prostorije (grejanje i hlađenje) - programiranje na dnevnom/nedeljnom nivou - 5 režima rada: automatski, ručni, holiday, jolly, isključeno - 3 nivoa temperature + antifriz - prikaz registrovane temperature - mogućnost povezivanja temperature sonde u pod - izračunava vreme uključivanja uređaja kako bi se mogla dostići željena temperatura prostorije prema utvrđenom rasporedu - izlaz sa naizmeničnim kontaktima NO+NC 5A (3A induktivno) 230V~ - opseg podešavanja temperature od 2°C do 40°C - napajanje pomoću 2 alkalne baterije tipa AA2x1,5V koje se ne isporučuju uz termostat - višezječni meni - rezerva napajanja (20°C) 1 godina <i>Electronic wall mounting Touch screen chronothermostat - backlit large display for room temperature control (heating and cooling) - daily/weekly programming - 5 operation modes: automatic, manual, holiday, jolly, off - 3 temperature levels + antifreeze - perceived temperature display - possibility of connection with a floor temperature probe - it calculates the switching on advance needed to reach the desired temperature at the fixed time - exit with switching contacts NO+NC 5A (3A inductive) 230V~ - temperature control range from 2°C to 40°C - powered with two alkaline batteries type AA 2x1,5V not included - menu with multilingual text guide - power supply (20 °C) 1 year</i>	Novo H.P. TECHNOLOGY	1 1
CRONOTC2B				
	CRONOTC3B			

**Napomena:** za instalacioni dijagram pogledati stranicu 129**Note:** see page 129 for installation exploding view
 Min. pakovanje kom.  
Min. Packaging pcs

 Stand. pakovanje kom.  
Std. Packaging pcs





# Serija DOMUS Touch

## DOMUS Touch series

Prekidači 250V~

One way switches 250V~

Dimenzije modula

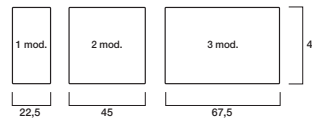

NEW WIRING ACCESSORIES



AVE PATENT N° 197  
AVE PATENT N° 197

102

Domus	Opis	Description	Info	€
-------	------	-------------	------	---



441001ST

**441001ST** 10 100  
 Mehanizam jednogpolnog prekidača 16AX sa svetlosnim indikatorom kompletira se sa tipkama od 1 ili 2 modula- 1 modul  
*1P 16AX one way lightable switch mechanism to be completed with 1 or 2 module rocker - 1 module*



441001  
441001/20A



441001/2

**441001** 10 100  
 Jednogpolni prekidač 16AX sa svetlosnim indikatorom - sa izmenljivom tipkom - 1 modul  
*1P 16AX one way lightable switch - interchangeable rocker - 1 module*

**441001/10A** 10 100  
 Jednogpolni prekidač 10AX sa svetlosnim indikatorom - sa izmenljivom tipkom - 1 modul  
*1P 10AX one way lightable plain switch - interchangeable rocker - 1 module*

**441001/20A** 10 100  
 Jednogpolni prekidač 20AX sa svetlosnim indikatorom - sa izmenljivom tipkom - 1 modul  
*1P 20AX one way lightable switch - interchangeable rocker - 1 module*

**441001/2** 5 50  
 Jednogpolni prekidač 16AX sa svetlosnim indikatorom - sa izmenljivom tipkom - 2 modula  
*1P 16AX one way lightable large switch - interchangeable rocker - 2 modules*



441001K3/10A  
441001K3/20A

**441001TL/2** 5 50  
 Jednogpolni glatki prekidač 10AX sa svetlosnim indikatorom - sa izmenljivom tipkom - 2 modula  
*1P 10AX one way lightable plain large switch - interchangeable rocker - 2 modules*

**441001K3/10A**  $\Delta$  5 5  
 Trostruki jednogpolni prekidač 10AX - 3 nezavisne tipke - 2 modula  
*Triple switch 1P 10AX - 3 independent rockers - 2 modules*

**441001K3/20A**  $\Delta$  5 5  
 Trostruki jednogpolni prekidač 20AX - 3 nezavisne tipke - 2 modula  
*Triple switch 1P 20AX - 3 independent rockers - 2 modules*



441001/10A



441001TL/2

**441010** 10 100  
 Dvogpolni prekidač 16AX sa svetlosnim indikatorom - sa izmenljivom tipkom - 1 modul  
*2P 16AX one way lightable switch - interchangeable rocker - 1 module*

**441010/20A** 10 100  
 Dvogpolni prekidač 20AX sa svetlosnim indikatorom - sa izmenljivom tipkom - 1 modul  
*2P 20AX one way lightable switch - interchangeable rocker - 1 module*

**441010/2** 5 50  
 Dvogpolni prekidač 16AX sa svetlosnim indikatorom - sa izmenljivom tipkom - 2 modula  
*2P 16AX one way lightable large switch - interchangeable rocker - 2 modules*



441010  
441010/20A



441010/2

**441071** 1 10  
 Dvogpolni prekidač 10AX sa ključem - nasumično kodiranje ključa - u kompletu sa 2 ključa - izvlačenje ključa iz obe pozicije - 1 modul  
*2P 10AX one way switch with key - random key coding - supplied with 2 keys - the key exits in both positions - 1 module*

**441071MC** 1 10  
 Dvogpolni prekidač 10AX sa unificiranim ključem - šifra ključa "511" - u kompletu sa 2 ključa - izvlačenje ključa iz obe pozicije - 1 modul  
*2P 10AX one way switch with unified key - key code "511" - supplied with 2 keys - the key exits in both positions - 1 module*



441071  
441071MC



**442010RS/20A** 1 10  
 Dvogpolni prekidač 20AX sa svetlosnim indikatorom - crveni - 1 modul  
*2P 20AX one way lightable switch - red - 1 module*



442010RS/20A

**Napomena:** ✓ prekidači sa ključem 44..071 i 442071MC samo na zahtev mogu biti isporučeni sa ključem koji se može izvaditi samo u položaju otvorenog prekidača  
 ✓ uređaji sa svetlosnim indikatorom isporučuju se bez indikatorskih lampica

**Note:** ✓ 441071 and 441071MC key switches can be supplied with key removable only in the open position upon request  
 ✓ lightable articles are supplied without lamp



Za raspoloživost kontaktirajte Ave distributere  
 For availability please contact sales dept.







Dostupni dok se ne rasprodaju zalihe  
 Available until stock out



Proizvod za pravougaone kutije britanskog standarda  
 Product for British standard rectangular box



Proizvod za izvoz  
 For Export only

Domus	Opis <i>Description</i>	Info	€
	<b>□ 441002ST</b> Mehanizam naizmieničnog jednopolnog prekidača 16AX sa svetlosnim indikatorom, kompletira se sa tipkama 1 ili 2 modula - 1 modul <i>1P 16AX two way lightable switch mechanism to be completed with 1 or 2 module rocker - 1 module</i>		10 100
<b>441002ST</b>	<b>□ 441002</b> Naizmienični jednopolni prekidač 16AX sa svetlosnim indikatorom - sa izmenljivom tipkom - 1 modul <i>1P 16AX two way lightable switch - interchangeable rocker - 1 module</i>		10 100
	<b>□ 441002/10A</b> Naizmienični jednopolni prekidač 10AX - sa izmenljivom tipkom - 1 modul <i>1P 10AX two way lightable plain switch - interchangeable rocker - 1 module</i>		10 100
<b>441002</b> <b>441002/20A</b>	<b>□ 441002/20A</b> Naizmienični jednopolni prekidač 10AX - sa izmenljivom tipkom - 2 modula <i>1P 20AX two way lightable switch - interchangeable rocker - 1 module</i>		10 100
	<b>□ 441002/2</b> Naizmienični jednopolni prekidač 16AX - sa izmenljivom tipkom - 2 modula <i>1P 16AX two way lightable large switch - interchangeable rocker - 2 modules</i>		5 50
<b>441002K3/10A</b> <b>441002K3/20A</b>	<b>□ 441002TL/2</b> Naizmienični jednopolni glatki prekidač 10AX sa svetlosnim indikatorom - sa izmenljivom tipkom - 2 modula <i>1P 10AX two way lightable plain large switch - interchangeable rocker - 2 modules</i>		5 50
	<b>□ 441002K3/10A</b> Trostruki naizmienični jednopolni prekidač 10AX - 3 nezavisne tipke - 2 modula <i>Triple 2 way switch 1P 10AX - 3 independent switches - 2 modules</i>	Δ	5 5
<b>441002/10A</b> <b>441002TL/2</b>	<b>□ 441002K3/20A</b> Trostruki naizmienični jednopolni prekidač 20AX - 3 nezavisne tipke - 2 modula <i>Triple 2 way switch 1P 20AX - 3 independent switches - 2 modules</i>	Δ	5 5
	<b>□ 441072</b> Naizmienični jednopolni prekidač 10AX sa ključem - nasumično kodiranje ključa - u kompletu sa 2 ključa - izvlačenje ključa iz obe pozicije - 1 modul <i>1P 10AX two way switch with key - random key coding - supplied with 2 keys - the key exits in both positions - 1 module</i>		1 10
<b>441072MC</b> <b>441072</b>	<b>□ 441072MC</b> Naizmienični jednopolni prekidač 10AX sa unificiranim ključem - šifra ključa "511" - u kompletu sa 2 ključa - izvlačenje ključa iz obe pozicije - 1 modul <i>1P 10AX two way switch with unified key - key code "511" - supplied with 2 keys - the key exits in both positions - 1 module</i>		1 10

**Napomena:** ✓ naizmienični prekidači sa ključem 441072 i 441072MC mogu se isporučiti sa ključem koji se može izvlačiti samo u "položaju otvorenog prekidača" jedino po narudžbini  
 ✓ uređaji sa svetlosnim indikatorom isporučuju se bez indikatorskih lampica  
**Note:** ✓ 441072 and 441072MC two way switches with key can be supplied with key removable only in the "0" position upon request  
 ✓ lightable articles are supplied without lamp

Komande Controls

Naizmienični prekidači Two Way Switches

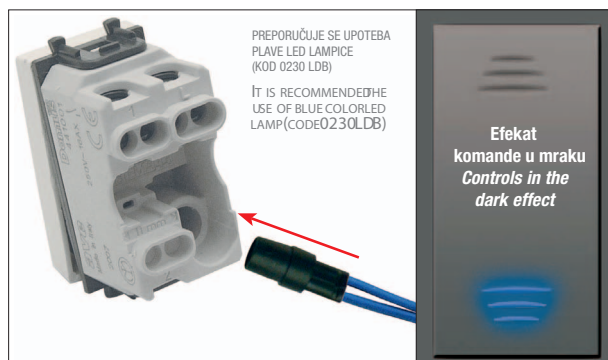

Postavljanje lampice  
Lamp insertion

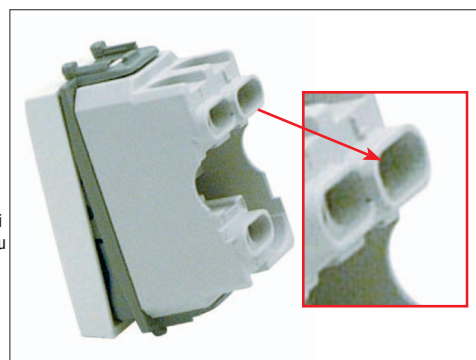

"Zajednički" kontakt uvećan radi trenutne identifikacije  
"Common" terminal raised for immediate identification



# Serija DOMUS Touch





DOMUS Touch series

Unakrsni prekidači 250V~  
Intermediate switches 250V~



AVE PATENT N° 197  
AVE PATENT N° 197





104

Domus	Opis	Description	Info	€
 441004ST	□ 441004ST Mehanizam unakrsnog jednogpolnog prekidača 16AX sa svetlosnim indikatorom - kompletira se sa tipkama od 1 ili 2 modula - 1 modul <i>1P 16AX lightable intermediate switch mechanism to be completed with 1 or 2 module rocker - 1 module</i>		10	100
 441004	□ 441004 Unakrsni jednogpolni prekidač 16AX sa svetlosnim indikatorom - sa izmenljivom tipkom - 1 modul <i>1P 16AX lightable intermediate switch - interchangeable rocker - 1 module</i>		10	100
 441004/20A	□ 441004/20A Unakrsni jednogpolni prekidač 20AX sa svetlosnim indikatorom - sa izmenljivom tipkom - 1 modul <i>1P 20AX lightable intermediate switch - interchangeable rocker - 1 module</i>		10	100
 441004/2	□ 441004/2 Unakrsni jednogpolni prekidač 16AX sa svetlosnim indikatorom - sa izmenljivom tipkom - 2 modula <i>1P 16AX lightable large intermediate switch - interchangeable rocker - 2 modules</i>		5	50
 441004TL/2	□ 441004TL/2 Unakrsni jednogpolni prekidač 16AX sa svetlosnim indikatorom - sa izmenljivom tipkom - 2 modula <i>1P 16AX lightable plain large intermediate switch - interchangeable rocker - 2 modules</i>		5	50

**Napomena:** isporučuju se bez indikatorskih lampica

**Note:** supplied without lamp

Izmenljive tipke za prekidače, naizmenične i unakrsne prekidače  
Interchangeable rockers for one way switch, two way switch and int. switch

Domus	Opis	Description	Info	€
 441T	□ 441T Izmenljiva obična tipka sa svetlosnim indikatorom - 1 modul <i>Interchangeable plain lightable rocker - 1 module</i>		14	14
 441T/2	□ 441TG Izmenljiva tipka sa svetlosnim indikatorom - difuzor je vidljiv čak i po danu - 1 modul <i>Interchangeable rocker with lightable lens - diffuser visible even by daylight - 1 module</i>		14	14
 441TG	□ 441T/2 Izmenljiva obična tipka sa svetlosnim indikatorom - 2 modula <i>Interchangeable plain lightable rocker - 2 modules</i>		7	7
 441TG/2	□ 441TG/2 Izmenljiva tipka sa svetlosnim indikatorom - difuzor je vidljiv čak i po danu - 2 modula <i>Interchangeable rocker with lightable lens - diffuser visible even in daylight - 2 modules</i>		7	7
 441TG/3	□ 441TG/3 Izmenljiva tipka sa svetlosnim indikatorom - difuzor je vidljiv čak i po danu - 3 modula <i>Interchangeable rocker with lightable lens - diffuser visible even in daylight - 3 modules</i>	<b>Novo</b>	2	2

Komande sa izmenljivim tipkama Controls with Interchangeable Rockers Pulsante con Targhetta Portanome Push button with name tag



Skidanje tipke  
Rocker removal

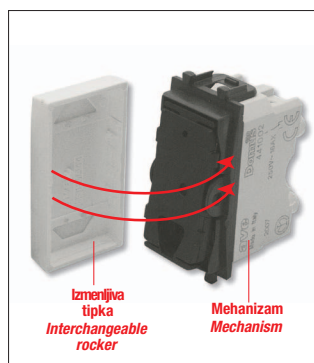

Postavljanje tipke  
Rocker assembly

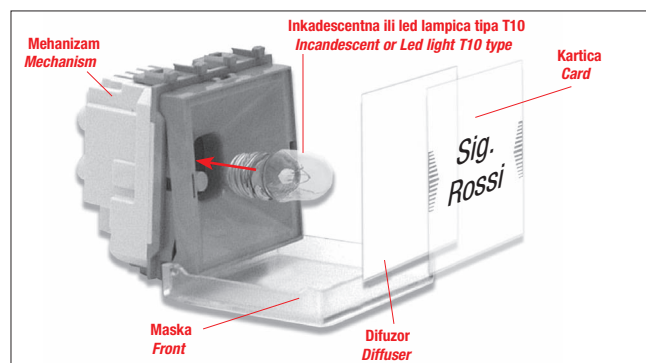

Postavljanje lampice i kartice  
Lamp and card assembly



Za raspoloživost kontaktirajte Ave distributere  
For availability please contact sales dept.

















Dostupni dok se ne rasprodaju zalihe  
Available until stock out



Proizvod za pravougaone kutije britanskog standarda  
Product for British standard rectangular box

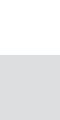

Proizvod za izvoz  
For Export only

Domus	Opis	Description	Info	€
	<b>441005ST</b>	<p>□ <b>441005ST</b> Mehanizam jedнопolnog NO tastera 10A sa svetlosnim indikatorom - kompletira se sa 1 ili 2 modula - 1 modul <i>1P NO 10A lightable push-button mechanism to be completed with 1 or 2 mod rocker</i> - 1 module</p>		10 100
	<b>441025</b>	<p>□ <b>441005</b> Jednopolni NO taster 10A sa svetlosnim indikatorom - sa izmenljivom tipkom - 1 modul <i>1P NO 10A lightable push-button - interchangeable rocker - 1 module</i></p>		10 100
	<b>441005/10A</b>	<p>□ <b>441005/10A</b> Jednopolni NO glatki taster 10A sa svetlosnim indikatorom - sa izmenljivom tipkom - 1 modul <i>1P NO 10A lightable plain push-button - interchangeable rocker - 1 module</i></p>	<b>Novo</b>	10 100
	<b>441005/2</b>	<p>□ <b>441005/2</b> Jednopolni NO taster 10A sa svetlosnim indikatorom - sa izmenljivom tipkom - 2 modula <i>1P NO 10A large lightable push-button - interchangeable rocker - 2 modules</i></p>		5 50
	<b>441005TL/2</b>	<p>□ <b>441005TL/2</b> Jednopolni NO glatki taster 10A sa svetlosnim indikatorom - sa izmenljivom tipkom - 2 modula <i>1P NO 10A plain large lightable push-button - interchangeable rocker - 2 modules</i></p>		5 50
	<b>441005/2</b>	<p>□ <b>441005/2P</b> Dvopolni NO taster 10A sa svetlosnim indikatorom - sa izmenljivom tipkom - 1 modul <i>2P NO 10A lightable push-button - interchangeable rocker - 1 module</i></p>		1 10
	<b>441056</b>	<p>□ <b>441025</b> Jednopolni NO+NC taster 10A sa svetlosnim indikatorom - sa izmenljivom tipkom - 1 modul <i>1P NO+NC 10A lightable push-button - interchangeable rocker - 1 module</i></p>		10 10
	<b>441056F</b>	<p>□ <b>441056</b> Jednopolni NO+ jednopolni NO dupli taster 10A sa svetlosnim indikatorom - bez interblok funkcije: dozvoljeno je istovremeno zatvaranje 2 strujna kola - 1 modul <i>1P NO + 1P NO 10A double push-button - lightable - without interblock: the simultaneous closure of the 2 circuits is allowed - 1 module</i></p>		1 10
	<b>441017</b>	<p>□ <b>441056F</b> Jednopolni NO + jednopolni NO dupli taster 10A sa svetlosnim indikatorom - bez interblok funkcije: dozvoljeno je istovremeno zatvaranje 2 strujna kola - 1 modul <i>1P NO + 1P NO 10A double push-button with arrows - lightable - without interblock : the simultaneous closure of the 2 circuits is allowed - 1 module</i></p>		1 10
	<b>441075</b>	<p>□ <b>441017</b> Jednopolni NO+NC potezni taster 10A - vrpca od izolacionog materijala dugačka 1,5 m - 1 modul <i>1P NO+NC 10A cord operated push-button - insulating material cord 1,5 m - 1 module</i></p>		1 10
	<b>441075MC</b>	<p>□ <b>441075</b> Dvopolni NO taster 10A sa ključem - nasumično kodiranje ključa - u kompletu sa 2 ključa - izvlačenje ključa samo iz pozicije OFF - 1 modul <i>2P NO 10A push-button with key - random key coding - supplied with 2 keys - the keys exits only in the open position - 1 module</i></p>		1 10
	<b>441075</b>	<p>□ <b>441075MC</b> Dvopolni NO taster 10A sa unificiranim ključem - fiksni kod "511" - u kompletu sa 2 ključa - izvlačenje ključa samo iz pozicije OFF - 1 modul <i>2P NO 10A push-button with unified key - key code "511" - supplied with 2 keys - the key exits only in the open position - 1 module</i></p>		1 10
	<b>441075MC</b>	<p>□ <b>441005TP/2</b> Jednopolni NO taster 10A sa pozadinskim osvetljenjem za karticu sa imenom - osvetljenje pomoću inkadescentne ili led lampice E10 10x28 mm tipa T10 1,5W max - isporučuje se bez lampice - isporučuje se sa personalizujućom karticom za natpis - 2 modula <i>1P NO 10A push-button with lightable name tag - illumination by incandescent or led lamp E10 10x28 mm T10 1,5W max type - supplied with customizable name tag card - supplied without lamp - 2 modules</i></p>		1 6
	<b>442025RS/2</b>	<p>■ <b>442025RS/2</b> Jednopolni NO+NC taster za slučaj opasnosti 10A - crvene boje - 2 modula <i>1P NO+NC 10A large emergency push-button - red - 2 modules</i></p>		1 6

**Napomena:** ✓ uređaji sa svetlosnim indikatorom se isporučuju bez indikatorskih lampica  
✓ 441056 i 441056F dozvoljavaju istovremeno zatvaranje dva strujna kola, nisu pogodni za kontrolu dvosmernih motora (npr. motori od roletni, žaluzina itd.)

**Notes:** ✓ *lightable articles are supplied without lamp*  
✓ *Since 441056 and 441056F allow the simultaneous closure of two circuits, they are not suitable for motor reversing (ex. rolling shutter, ecc.)*



# Serija DOMUS Touch

DOMUS Touch series











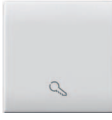

Izmenljive tipke za tastere

Interchangeable rockers for push buttons

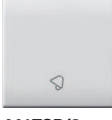

AVE PATENT N° 197  
AVE PATENT N° 197

106

Domus	Opis	Description	Info	€
 441T	 441T/2	<input type="checkbox"/> 441T Izmenljiva obična tipka sa svetlosnim indikatorom nevidljivim po danu - 1 modul <i>Interchangeable plain lighttable rocker - 1 module</i>	14	14
		<input type="checkbox"/> 441T/2 Izmenljiva obična tipka sa svetlosnim indikatorom nevidljivim po danu - 2 modula <i>Interchangeable plain lighttable rocker - 2 modules</i>	7	7
 441TGP	 441TGP/2	<input type="checkbox"/> 441TGP Izmenljiva tipka sa svetlosnim idnikatorom - difuzor vidljiv čak i po danu - 1 modul <i>Interchangeable rocker with lighttable lens - diffuser visible even in daylight - 1 module</i>	14	14
		<input type="checkbox"/> 441TGP/2 Izmenljiva tipka sa svetlosnim indikatorom - difuzor vidljiv čak i po danu - 2 modula <i>Interchangeable rocker with lighttable lens - diffuser visible even in daylight - 2 modules</i>	7	7
 441TKP	 441TKP/2	<input type="checkbox"/> 441TKP Izmenljiva tipka sa svetlećim simbolom KLJUČA - 1 modul <i>Interchangeable rocker with lighttable KEY symbol - 1 module</i>	14	14
		<input type="checkbox"/> 441TKP/2 Izmenljiva tipka sa svetlećim simbolom KLJUČA - 2 modula <i>Interchangeable rocker with lighttable KEY symbol - 2 modules</i>	7	7
 441TLP	 441TLP/2	<input type="checkbox"/> 441TLP Izmenljiva tipka sa svetlećim simbolom SVETILJKE - 1 modul <i>Interchangeable rocker with lighttable LAMP symbol - 1 module</i>	14	14
		<input type="checkbox"/> 441TLP/2 Izmenljiva tipka sa svetlećim simbolom SVETILJKE - 2 modula <i>Interchangeable rocker with lighttable LAMP symbol - 2 modules</i>	7	7
 441TSP	 441TSP/2	<input type="checkbox"/> 441TSP Izmenljiva tipka sa svetlećim simbolom ZVONA - 1 modul <i>Interchangeable rocker with lighttable BELL symbol - 1 module</i>	14	14
		<input type="checkbox"/> 441TSP/2 Izmenljiva tipka sa svetlećim simbolom ZVONA - 2 modula <i>Interchangeable rocker with lighttable BELL symbol - 2 modules</i>	7	7
 441TLSP		<input type="checkbox"/> 441TLSP Izmenljiva tipka sa svetlećim simbolom STEPENIŠNOG SVETLA - 1 modul <i>Interchangeable rocker with lighttable STAIR LIGHT symbol - 1 module</i>	14	14
		<input type="checkbox"/> 441TBP Izmenljiva tipka sa svetlećim simbolom BOJLERA - 1 modul <i>Interchangeable rocker with lighttable BOILER symbol - 1 module</i>	14	14
		<input type="checkbox"/> 441TREP Izmenljiva tipka sa svetlećim simbolom ELEKTRIČNE GREJALICE- 1 modul <i>Interchangeable rocker with lighttable ELECTRIC RESISTANCE symbol - 1 module</i>	14	14
 441TBP		<input type="checkbox"/> 441TG/3 Izmenljiva tipka sa svetlosnim idnikatorom vidljivim i po danu - 3 modula <i>Interchangeable rocker with lighttable lens - diffuser visible even in daylight - 3 modules</i>	<b>Novo</b>	2 2
 441TREP				
 441TG/3				

### Osvetljavanje simbola *Illumination for Symbols*

Ukloniti plastični poklopac samo za tipke sa simbolima  
*Pull the removable cover only for rockers with symbol*

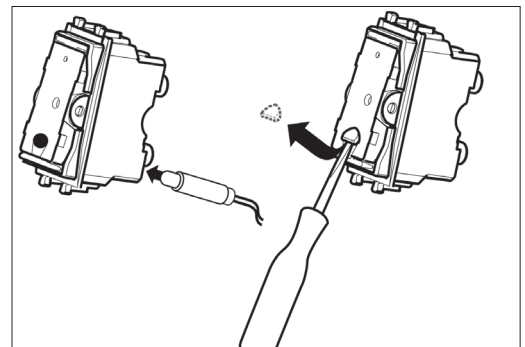

Za raspoloživost kontaktirajte Ave distributere  
For availability please contact sales dept.



Dostupni dok se ne rasprodaju zalihe  
Available until stock out





Proizvod za pravougaone kutije britanskog standarda  
Product for British standard rectangular box



Proizvod za izvoz  
For Export only

## Dvosmerni prekidači za roletne 250V~ Rolling blind switches 250V~

AVE PATENT № 197  
AVE PATENT № 197

Domus	Opis	Description	Info	€
 <b>441051</b> 441052	 <b>441053</b> 441054	<b>□ 441051</b> Dvosmerni jednopolni prekidač za roletne 10AX (3 priključka) - 3 položaja (središnji OFF), sa interblok funkcijom - 2 tipke sa strelicama - 1 modul <i>1P 10AX rolling blind switch (3 terminals) - 3 positions (central OFF) - with interblock - 2 rockers- with arrows - 1 module</i>	1	10
		<b>□ 441052</b> Dvosmerni dvopolni prekidač za roletne 10AX (6 priključaka) - 3 položaja (središnji OFF) - sa interblok funkcijom - 2 tipke sa strelicama - 1 modul <i>2P 10AX rolling blind switch (6 terminals) - 3 positions (central OFF) - with interblock - 2 rockers - with arrows - 1 module</i>	1	10
		<b>□ 441053</b> Dvosmerni jednopolni taster za roletne 10A (3 priključka) - 3 položaja (središnji OFF) - sa interblok funkcijom - 2 tipke sa strelicama - 1 modul <i>1P 10A rolling blind push button (3 terminals) - 3 positions (central OFF) - with interblock - 2 rockers - with arrows - 1 module</i>	1	10
		<b>□ 441054</b> Dvosmerni dvopolni taster za roletne 10A (6 priključaka) - 3 položaja (središnji OFF) - sa interblok funkcijom - 2 tipke sa strelicama - 1 modul <i>2P 10A rolling blind push button (6 terminals) - 3 positions (central OFF) - with interblock - 2 rockers - with arrows - 1 module</i>	1	10





107



Sistema 45

## Prekidači 230V~ i tasteri 230V~ “na dodir”

## Switches 230V~ and push button 230V~ “touch”

Domus	Opis	Description	Info	€
 <b>441001S</b>	 <b>441001S/2F</b>	<b>□ 441001S</b> Elektronski prekidač na dodir sa relejnim izlazom 1P NO 10A 230V~ - upravljanje dodirivanjem prednje površine ili sa više lokacija pomoću NO tastera - bistabilni režim rada - LED male potrošnje za identifikaciju u mraku - memorija stanja relejnog izlaza u slučaju nestanka struje - napajanje 230V~ - 1 modul <i>Electronic touch switch - relay output 1P NO 10A 230V~ - controlled by touching the frontal area or from multiple points with NO push buttons - bistable operating mode - low consumption led for identification in the dark - output relay status memorization in case of black out - 230V~ power supply - 1 module</i>	1	10
 <b>441005S</b>		<b>□ 441001S/2F</b> Elektronski prekidač na dodir 230V~ - “2 žice” sa trijak izlazom za rezistivna i induktivna opterećenja (inkandescentne i halogene svetiljke 40-400W, feromagnetne transformatore za halogene svetiljke niskog napona 40-400VA, za induktivne elektronske transformatore  40-300VA tipa OSRAM HALOTRONIC HTM 70/230-240, HTM 105/230-240, HTM 150/230-240) - upravljanje dodirivanjem prednje površine ili sa više lokacija pomoću NO tastera - bistabilni režim rada - LED male potrošnje za identifikaciju u mraku - memorija stanja relejnog izlaza u slučaju nestanka struje - 1 modul <i>Electronic touch switch “2 wires” 230V~ with TRIAC output for resistive and inductive loads (incandescent and halogen lamps 40-400W, ferromagnetic transformers for low voltage 40-400 VA halogen lamps, electronic inductive transformer type  40-300VA OSRAM HALOTRONIC HTM 70/230-240, HTM 105/230-240, HTM 150/230-240) - controlled by touching the frontal area or from multiple points with NO push buttons - bistable operating mode - low consumption led for identification in the darkness - output status memorization in case of black out - 1 module</i>	1	10
		<b>□ 441005S</b> Elektronski taster na dodir za udaljenu kontrolu - upravljanje dodirivanjem prednje površine - monostabilna funkcija - LED male potrošnje za identifikaciju u mraku - napajanje 230V~ - koristi se sa elektronskim prekidačem 441001S, 441001S/2F, sa dimerom na dodir 441048SU ili dvosmernim prekidačem na dodir 441051S - 1 modul <i>Electronic push button for remote control with touch sensor - controlled by touching the frontal area - monostable operating mode - low consumption led for identification in the dark - 230V~ power supply - to be coupled with electronic switch 441001S, 441001S/2F, with touch dimmer 441048SU or touch rolling blind switch 441051S - 1 module</i>	1	10

**Napomena:** 441001S/2F ne savetuje se instalacija više od jednog prekidača u istu kutiju  
**Note:** 441001S/2F it is recommended to not install more than one switch in the same box

Min. pakovanje kom.  
Min. Packaging pcs

Stand. pakovanje kom.  
Std. Packaging pcs



# Serija DOMUS Touch

DOMUS Touch series





## Dvosmerni prekidač za roletne 230V~ "na dodir" Rolling blind switch 230V~ "touch"

108



Domus	Opis Description	Info	€
 441051S	<p><b>□ 441051S</b></p> <p>Dvosmerni elektronski prekidač sa 2 monostabilna relejna izlaza sa NO kontaktima 2A 230V~ - upravljanje dodirivanjem prednje površine ili sa više lokacija pomoću NO tastera - monostabilan i vremenski programiran režim rada - LED male potrošnje za identifikaciju u mraku - napajanje 230V~ - 1 modul</p> <p><i>Electronic touch rolling blind switch with 2 monostable relay output, NO contact 2A 230V~ - controlled by touching the frontal area or from multiple points with NO push buttons - monostable or timed operating mode - low consumption LED for identification in the dark - 230V~ power supply - 1 module</i></p>	1	10

## Dimer za svetiljke 230V~ "na dodir"

## Dimmer for lights 230V~ "touch"

Domus	Opis Description	Info	€
 441048SU	<p><b>□ 441048SU</b></p> <p>Regulator inteziteta svetlosti 230V~ za rezistivne i induktivne potrošače (inkandescentne i halogene svetiljke 40-400W, feromagnetne transformatore za halogene svetiljke niskog napona 40-400VA, za induktivne elektronske transformatore  40-300VA tipa OSRAM HALOTRONIC HTM 70/230-240, HTM 105/230-240, HTM 150/230-240) upravljanje i podešavanje dodirivanjem prednje površine ili sa više lokacija pomoću NO tastera - LED male potrošnje za identifikaciju u mraku - memorija stanja relejnog izlaza u slučaju nestanka struje - 1 modul</p> <p><i>230V~ dimmer for resistive and inductive loads (incandescent and halogen lamps 40-400W, ferromagnetic transformers for low voltage 40-400 VA halogen lamps, electronic inductive transformer type  40-300VA OSRAM HALOTRONIC HTM 70/230-240, HTM 105/230-240, HTM 150/230-240) - controlled by touching the frontal area or from multiple points with NO buttons - low consumption led for identification in the darkness - output and level relay status memorization in case of black out - 1 module</i></p> <p><b>Napomena:</b> ne savetuje se instalacija više od jednog modula u istu kutiju <b>Note:</b> it is recommended to not install more than one dimmer in the same box</p>	1	10

## IC detektor prisustva za kontrolu rasvete Detectors

Domus	Opis Description	Info	€	
 441068/3F	<p><b>□ 441068/3F</b></p> <p>SVETLO DOBRODOŠLICE linfracrveni detektor prisustva za kontrolu rasvete - povezivanje sa 3 žice - napajanje 230V~ - regulacija trajanja vremenskog ciklusa (off kašnjenja) od 20s do 5 min - kontrola potrošača snage 25÷200W - podešavanje svetlosne osetljivosti - fiksno sočivo dometa 9 m/150° - 1 modul</p> <p><i>LUCE AMICA Infrared detector for lighting control - 3 wires cabling - 230V~ input - frontal duty cycle time regulation from 20 s to 5 min - 25÷200W controllable load - frontal regulation of light sensitivity - fixed lens with 9 m range and 150° opening - 1 module</i></p>	1	6	
 441068RL		<p><b>□ 441068RL</b></p> <p>SVETLO DOBRODOŠLICE infracrveni detektor prisustva za kontrolu rasvete - relejni izlaz NO 10(4)A 230V - napajanje 230V - podešavanje trajanja vremenskog ciklusa (off kašnjenja) od 10s do 7 min - podešavanje praga osetljivosti osvetljenja prostorije - fiksno sočivo dometa koji se može podešavati od 2m do 12m i otvaranja 150° - ulaz za tastere daljinske kontrole - mogućnost podešavanja režima rada: automatski/sumrak/prinudno ON/poluautomatski - 1 modul</p> <p><i>LUCE AMICA Infrared motion detector for lighting control - NO 10(4)A 230V~ output relay - 230V~ power supply - Frontal duty cycle time regulation from 10 s to 7 min - Frontal regulation of light sensitivity threshold - fixed lens range from 2 m to 12 m and 150° opening - input for remote controls push buttons - possibility to set operating mode: Automatic/Night/Forced ON/Semi-Automatic - 1 module</i></p>	<b>Novo</b>	1



Za raspoloživost kontaktirajte Ave distributere  
For availability please contact sales dept.



Dostupni dok se ne rasprodaju zalihe  
Available until stock out



Proizvod za pravougaone kutije britanskog standarda  
Product for British standard rectangular box



Proizvod za izvoz  
For Export only

## Elektromehanički relej Electromechanical relay

Domus	Opis	Description	Info	€
	<b>□ 441074M/230V</b>	Bistabilni elektromehanički relej - upravljanje sa više lokacija pomoću NO tastera - izlaz sa jedнопolnim NO kontaktom 10A - napajanje namotaja 230V~ - 1 modul <i>Stepper electromechanical relay - control from multiple points by normal push buttons NO - 1P NO 10A output with contact - coil input 230V~ - 1 module</i>	1	10





441074M/230V

109



Sistema 45

## Slepi modul i izlaz za kabl      Blank insert and Cable Outlet

Domus	Opis	Description	Info	€
	<b>□ 441008</b>	Izlaz za kabl Ø 9 mm sa držačem kabla - omogućava prolaz kablova od Ø 4 mm do Ø 8 mm - 1 modul <i>Cable outlet Ø 9 mm with cable grip - it allows the passage of cables from Ø 4 mm to Ø 8 mm - 1 module</i>	10	100
	<b>□ 441013</b>	Slepi modul - omogućava pravljenje otvora za montažu različitih konektora - 1 modul <i>Blank insert - central pre-cut in rear side to facilitate any holes - 1 module</i>	10	300
	<b>□ 441013R</b>	Slepi modul- omogućava pravljenje otvora za montažu različitih konektora - 1/2 modula <i>Blank insert - central pre-cut in rear side to facilitate any holes - 1/2 module</i>	12	72
	<b>□ 441013A/2</b>	Slepi modul pripremljen za kačenje na praznu kutiju za 2 modula - 2 modula <i>Equippable blank insert - preset for clipping it to empty box - 2 modules</i>	4	24

441008

441013

441013R

441013A/2

**Napomena:** po porudžbini može se isporučiti i kutija 2 modula za kačenje slepog modula 441013A/2  
**Note:** the 2 modules box for the 441013A/2 blank insert clipping can be supplied upon request





# Serija DOMUS Touch

DOMUS Touch series



Radio-predajnici i radio-prijemnici  
Transmitters and radio receivers

110

Opis Description Info €



T4R

**T4R**  
4 - kanalni predajnik - omogućava slanje 4 radio komande ka prijemnicima R1R i RT1R - napajanje 230V ~ - može biti instaliran na slepi modul Domus100 441013 ili u razvodnu kutiju - dimenzije: 40x18x33 mm  
4-channel transmitter - it allows the transmission of 4 radio controls to R1R and RT1R receivers - 230Vac power supply - it can be installed on blank insert Domus100 441013 or in junction boxes - dimensions: 40x18x33 mm



R1R

**R1R**  
1 - kanalni radio-prijemnik - napajanje 230V ~ -snaga kontakta: 1000W/500VA na 230V~ - može biti instaliran na slepi modul Domus100 441013 ili u razvodnu kutiju - dimenzije: 40x18x33 mm  
1-channel radio receiver - 230Vac power supply - it can be installed on blank insert Domus100 441013 or in junction boxes - contact load: 1000W/500VA at 230Vac - dimensions: 40x18x33 mm



RT1R

**RT1R**  
1 - kanalni radio-prijemnik za upravljanje roletnama i žaluzinama - napajanje 230V~ - izlaz sa interblok funkcijom snage 500VA na 230V~ - može biti instaliran na slepi modul Domus100 441013 ili u razvodnu kutiju - dimenzije: 40x18x33 mm  
1-channel radio receiver for rolling shutters or curtains motor control - 230Vac power supply - it can be installed on blind front cover Domus100 441013 or in junction boxes - output with interlocked contacts with a 500VA load at 230Vac - dimensions: 40x18x33 mm



AF940R

**AF940R**  
Daljinski upravljač sa 4 dugmeta za upravljanje radio-prijemnicima - dimenzije: 41x41x10 mm  
4 push button remote control for radio receivers - dimensions: 41x41x10 mm



T9R

**T9R**  
Daljinski upravljač sa 9 dugmića za upravljanje radio-prijemnicima - dimenzije: 41x41x10 mm  
9-push button remote control for radio receivers. Dimensions: 41x41x10 mm

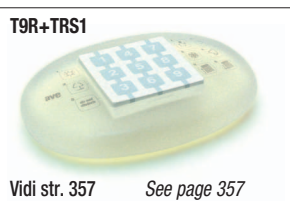

Vidi str. 357 See page 357

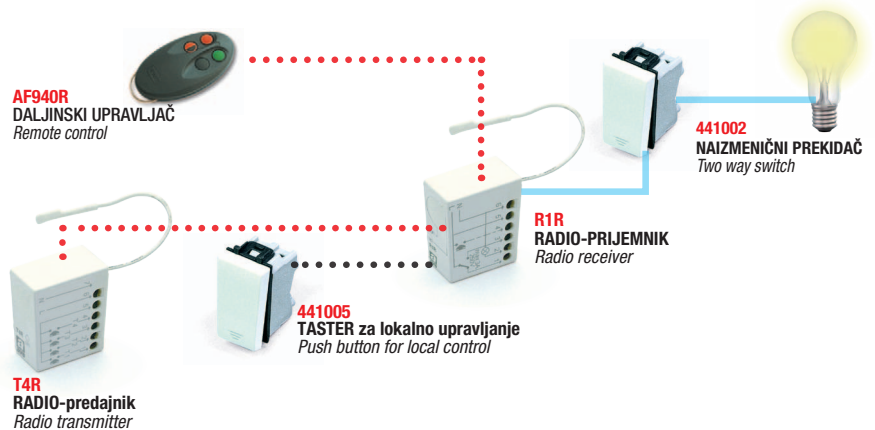

## Primer instalacije Installation example

Predajnik ili prijemnik mogu biti postavljeni iza slepog modula Domus100 (441013) i pričvršćeni na odgovarajuću armaturu  
The transmitting or receiving module can be placed behind the Domus100 blank insert (code 441013) and clipped to the frame

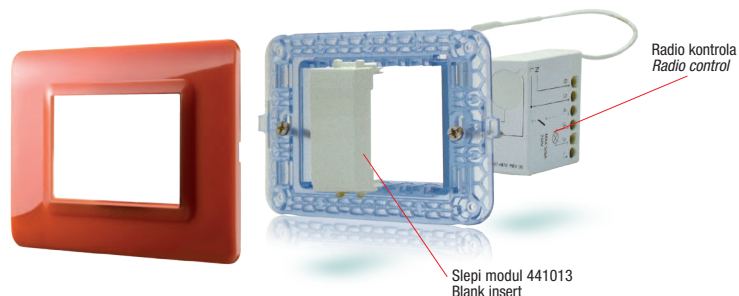

Za raspoloživost kontaktirajte Ave distributere  
For availability please contact sales dept.



Dostupni dok se ne rasprodaju zalihe  
Available until stock out



Proizvod za pravougaone kutije britanskog standarda  
Product for British standard rectangular box



Proizvod za izvoz  
For Export only

## Utičnice italijanskog standarda 250V~ 250V~ Italian standard socket outlets

Domus	Opis	Description	Info	€
<p>441006/15TS    441006TS</p>	<p>□ 441006/15TS</p> <p>Kombinovana utičnica P17/11 2P+Z 10/16A - sa zaštićenim kontaktima - mogućnost upotrebe izolovanog prespojnika 442PONTE za brzo povezivanje više utičnica u nizu - 1 modul</p> <p>Combined P17/11 Italian standard socket 2P+E 10/16A - shuttered - possibility of using insulated jumper code 442PONTE for rapid wiring of more sockets side by side 1 module</p>		10	100
<p>441090TS    441090TSS</p>	<p>□ 441006TS</p> <p>Utičnica P11 2P+Z 10A - sa zaštićenim kontaktima - mogućnost upotrebe izolovanog prespojnika 442PONTE za brzo povezivanje više utičnica u nizu - 1 modul</p> <p>P11 2P+E 10A socket - shuttered - possibility of using insulated jumper code 442PONTE for rapid wiring of more sockets side by side - 1 module</p>		10	100
<p>441090/15TS</p>	<p>□ 441090TS</p> <p>Šuko utičnica P30 2P+Z 16A - sa zaštićenim kontaktima - sa svetlosnim indikatorom (signalizira prisustvo mrežnog napajanja) - bočni i centralni kontakti uzemljenja - 2 modula</p> <p>P30 2P+E 16A Schuko socket - shuttered - lightable (indicating the presence of the line) - lateral and central earth contacts - 2 modules</p>		5	50
<p>442PONTE</p>	<p>□ 441090TSS</p> <p>Šuko utičnica sa poklopcem P30 2P+Z 16A - sa zaštićenim kontaktima - bočni i centralni kontakti uzemljenja - 2 modula</p> <p>P30 2P+E 16A Schuko socket with lid - shuttered - lateral and central earth contacts - 2 modules</p>	<b>Novo</b>	5	50
	<p>□ 441090/15TS</p> <p>Šuko utičnica kombinovana (UNIVERZALNA) 2P+Z 10/16A - sa zaštićenim kontaktima - sa svetlosnim indikatorom (signalizira prisustvo mrežnog napajanja) - 2 modula</p> <p>2P+E 10/16A (UNIVERSAL) combined Schuko + Italian standard socket - shuttered - lightable (indicating the presence of the line) - 2 modules</p>		5	50
	<p>□ 442PONTE</p> <p>Izolovani prespojnik za brzo povezivanje 2 susedne utičnice italijanskog standarda</p> <p>1 modul - monoblok faza/zemlja/nula - preporučuje se upotreba kablova preseka <b>2,5mm<sup>2</sup></b> ili <b>4 mm<sup>2</sup></b></p> <p>Insulated jumper for rapid wiring of 2 italian standard 1 module sockets side by side - single block phase/earth/neutral - it is recommended the use of <b>2,5 mm<sup>2</sup> or 4 mm<sup>2</sup></b> cables</p> <p><b>Napomena:</b> uređaji sa svetlosnim indikatorom se isporučuju bez indikatorne lampice</p> <p><b>Note:</b> lightable articles are supplied without lamp</p>		50	50

111

Sistema 45

### Utičnice italijanskog standarda Standard Italian Socket Outlets

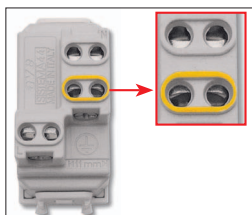

Priključak za uzemljenje je obeležen žutom bojom radi brže identifikacije  
Earth terminal highlighted for immediate identification

### Šuko utičnice Schuko Socket Outlets

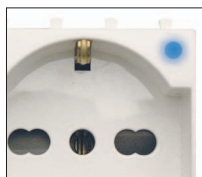

Utičnica sa svetlosnim indikatorom  
Illuminated socket outlets

Predlaže se upotreba led lampice plave boje (0230LDB)

It is recommended the use of blue color led lamp (code 0230LDB)

### Utičnice italijanskog standarda - 1 modul Italian Standard Socket Outlets 1 module



2 utičnice povezane preko izolovanog prespojnika  
2 sockets wired with insulated jumper

## Utičnica za aparate za brijanje 230V~ 230V~ shaver socket

Domus	Opis	Description	Info	€
<p>441033RS</p>	<p>□ 441033RS</p> <p>Utičnica za aparat za brijanje sa izolacionim transformatorom 20VA - evro/američki standard - napajanje 230V~ - mogućnost izbora izlaznog napona preko ugrađenog naizmeničnog prekidača 240V~ ili 120V~ - sa zaštićenim kontaktima - 3 modula</p> <p>Shaver socket with 20VA insulating transformer - Euro-American standard - 230V~ input - voltage available at the output selectable by rolling blind switch 240V~ or 120V~ - shuttered - 3 modules</p>		1	1
	<p><b>Napomena:</b> utičnica poseduje ugrađeni osigurač</p> <p><b>Note:</b> the socket is supplied with a built-in surge protection device</p>			

□ Min. pakovanje kom.  
Min. Packaging pcs

□ Stand. pakovanje kom.  
Std. Packaging pcs



# Serija DOMUS Touch

DOMUS Touch series



Utičnice za namenske strujne krugove 250V~  
Socket outlets for dedicated circuits 250V~

112

		Opis	Description	Info	€
		<b>442006/15TSR</b>	<b>442006/15TSR</b> Kombinovana utičnica P17/11 italijanskog standarda 2P+Z 10/16A - sa zaštićenim kontaktima - crvene boje - mogućnost upotrebe izolovanog prespojnika 442PONTE za brzo povezivanje više utičnica u nizu - 1 modul Combined P17/11 Italian standard socket 2P+E 10/16A - shuttered - red - possibility of using insulated jumper code 442PONTE for rapid wiring of more sockets side by side - 1 module	10	100
		<b>442006/15TSV</b>	<b>442006/15TSV</b> Kombinovana utičnica P17/11 italijanskog standarda 2P+Z 10/16A - sa zaštićenim kontaktima - zelene boje - mogućnost upotrebe izolovanog prespojnika 442PONTE za brzo povezivanje više utičnica u nizu - 1 modul Combined P17/11 Italian standard socket 2P+E 10/16A - shuttered - green - possibility of using insulated jumper code 442PONTE for rapid wiring of more sockets side by side - 1 module	10	100
		<b>442006/15TSA</b>	<b>442006/15TSA</b> Kombinovana utičnica P17/11 italijanskog standarda 2P+Z 10/16A - sa zaštićenim kontaktima - narandžaste boje - mogućnost upotrebe izolovanog prespojnika 442PONTE za brzo povezivanje više utičnica u nizu - 1 modul Combined P17/11 Italian standard socket 2P+E 10/16A - shuttered - orange - possibility of using insulated jumper code 442PONTE for rapid wiring of more sockets side by side - 1 module.	10	100
		<b>442090TSR</b>	<b>442090TSR</b> Šuko utičnica P30 2P+Z 16A - sa zaštićenim kontaktima - crvene boje - sa svetlosnim indikatorom (signalizira prisustvo mrežnog napajanja) - bočni i centralni kontakt uzemljenja - 2 modula P30 2P+E 16A Schuko socket - shuttered - red - lightable (indicating the line presence) - lateral and central earth contacts - 2 modules	5	50
		<b>442090/15TSR</b>	<b>442090/15TSR</b> Kombinovana šuko utičnica (UNIVERZALNA) 2P+Z 10/16A - sa zaštićenim kontaktima - crvene boje - sa svetlosnim indikatorom (signalizira prisustvo mrežnog napajanja) - 2 modula 2P+E 10/16A (UNIVERSAL) Schuko + Italian standard socket - shuttered - red - lightable (indicating the line presence) - 2 modules	5	50
		<b>442090/15TSV</b>	<b>442090/15TSV</b> Kombinovana šuko utičnica (UNIVERZALNA) 2P+Z 10/16A - sa zaštićenim kontaktima - zelene boje - sa svetlosnim indikatorom (signalizira prisustvo mrežnog napajanja) - 2 modula 2P+E 10/16A (UNIVERSAL) Schuko + Italian standard socket - shuttered - green - lightable (indicating the line presence) - 2 modules	5	50
		<b>442090/15TSA</b>	<b>442090/15TSA</b> Kombinovana šuko utičnica (UNIVERZALNA) 2P+Z 10/16A - sa zaštićenim kontaktima - narandžaste boje - sa svetlosnim indikatorom (signalizira prisustvo mrežnog napajanja) - 2 modula 2P+E 10/16A (UNIVERSAL) Schuko + Italian standard socket - shuttered - orange - lightable (indicating the presence of the line) - 2 modules	5	50

**Napomena:** uređaji sa svetlosnim indikatorom se isporučuju bez indikatorske lampice

**Nota:** lightable articles are supplied without lamp

## Uobičajena mesta primene Predominant field of application

### Crvena:

Strujni krugovi napajani preko UPS-a

### Red:

Line powered by a UPS



### Zelena:

Strujni krugovi napajani preko dizel agregata

### Green:

Line powered by a network/power unit



### Narandžasta:

Strujni kurgovi napajani preko dizel agregata i izolacionog transformatora

### Orange:

Line powered by a network/power unit and insulation transformer



**Napomena:** Primeri premene navedeni iznad predstavljaju samo smernice i ne postoje nikakvi standardi koji ovo regulišu

**Nota:** the above examples are purely indicative as no specific standard regulations are available



Za raspoloživost kontaktirajte Ave distributere  
For availability please contact sales dept.



Dostupni dok se ne rasprodaju zalihe  
Available until stock out





Proizvod za pravougaone kutije britanskog standarda  
Product for British standard rectangular box



Proizvod za izvoz  
For Export only

## Utičnice stranih standarda

### Various standards socket outlets

Domus	Opis	Description	Info	€
	<input type="checkbox"/>	<b>441090S</b>	Δ	5 50
	Utičnica nemačkog standarda 2P+Z 16A 250V~ - sa zaštićenim kontaktima - sa svetlosnim indikatorom (signalizira prisustvo mrežnog napajanja) - 2 modula <i>2P+E 16A 250V~ German standard socket - shuttered - lightable (indicating the presence of the line) - 2 modules</i>			
	<input type="checkbox"/>	<b>441090SS</b>	Δ	5 50
	Utičnica nemačkog standarda 2P+Z 16A 250V~ sa poklopcem - sa zaštićenim kontaktima - upotrebljava se sa kutijama minimalne dubine 45 mm - 2 modula <i>2P+E 16A 250V~ German standard socket with lid - shuttered - to be used in boxes with min. depth 45 mm - 2 modules</i>			

113



Sistema 45

nastavak see next page >

Min. pakovanje kom.  
Min. Packaging pcs

Stand. pakovanje kom.  
Std. Packaging pcs



# Serija DOMUS Touch

DOMUS Touch series



Priključnice za specijalnu namenu  
Socket outlets for special use

114

Domus	Opis	Description	Info	€
 441082USB	<input type="checkbox"/> 441082USB	Univerzalni USB punjač 5V 1,2A - 2 USB izalaza sa prednje strane - napajanje 110÷230V~ 50-60 Hz - omogućava punjenje mobilnih telefona, prenosivih audio uređaja, i svih ostalih elektronskih uređaja koje je moguće puniti preko USB ulaza bilo kog tipa - 2 modula <i>Universal USB charger 5V 1,2A - 2 frontal USB outputs - powered with 110÷230V~ 50-60 Hz - allows the charging of mobile phones, mobile audio player, and all electronic devices that allows the charge through standard USB Inputs - 2 modules</i>	<b>Novo</b>	1 1

## Telefonska priključnica Telephone socket outlets

Domus	Opis	Description	Info	€
 441024	<input type="checkbox"/> 441024	Telefonska priključnica RJ11 (6 polova/4 kontakta) - priključci sa šrafovm - 1 modul <i>RJ11 Telephone socket (6 poles / 4 contacts) - screw terminals - 1 module</i>		2 12



Za raspoloživost kontaktirajte  
Ave distributere  
For availability please contact  
sales dept.



Dostupni dok se ne  
rasprodaju zalihe  
Available until stock out







Proizvod za pravougaone  
kutije britanskog standarda  
Product for British standard  
rectangular box



Proizvod za  
izvoz  
For Export  
only



## Računarske priključnice Data outlets

Domus	Opis	Description	Info	€
	<b>441027C5E</b>	<p>□ <b>441027C5E</b></p> <p>Priključnica Ave RJ45 kategorija 5e UTP - neoklopljena - žabice za spajanje kabela uz pomoć alata - T568A i T568B standard - 8 kontakata - 1 modul  <i>RJ45 category 5 enhanced outlet - not shuttered - AVE connector - insulation piercing terminals - T568A and T568B universal wiring - 8 contacts - 1 module</i></p>	1	10
	<b>441027C6</b>	<p>□ <b>441027C6</b></p> <p>Priključnica Ave RJ45 kategorija 6 UTP - neoklopljena - žabice za spajanje kabela uz pomoć alata - T568A i T568B standard - 8 kontakata - 1 modul  <i>RJ45 category 6 outlet - not shuttered - AVE connector - insulation piercing terminals - T568A and T568B universal wiring - 8 contacts - 1 module</i></p> <p>□ <b>441029C5E</b></p> <p>Priključnica 3M RJ45 kategorija 5e UTP - neoklopljena - žabice za brzo spajanje kabela bez alata - T568A i T568B standard - 8 kontakata - poklopac protiv prašine ugrađen na konektor - 1 modul  <i>RJ45 category 5 enhanced outlet - not shuttered - 3M connector - insulation piercing terminals with rapid wiring - T568A and T568B universal wiring - 8 contacts - anti-dust lid integrated in the connector - 1 module</i></p>	1	10
	<b>441029C5E</b> <b>441029C6</b>	<p>□ <b>441029C5E</b></p> <p>Priključnica 3M RJ45 kategorija 5e FTP - oklopljena - žabice za brzo spajanje kabela bez alata - T568A i T568B standard - 8 kontakata - poklopac protiv prašine ugrađen na konektor - 1 modul  <i>RJ45 category 5 enhanced outlet - shuttered - 3M connector - insulation piercing terminals with rapid wiring - T568A and T568B universal wiring - 8 contacts - anti-dust lid integrated in the connector - 1 module</i></p>	1	10
	<b>441029C5ES</b> <b>441029C6S</b>	<p>□ <b>441029C6</b></p> <p>Priključnica 3M RJ45 kategorija 6 UTP - neoklopljena - žabice za brzo spajanje kabela bez alata - T568A i T568B standard - 8 kontakata - poklopac protiv prašine ugrađen na konektor - 1 modul  <i>RJ45 category 6 outlet - not shuttered - 3M connector - insulation piercing terminals with rapid wiring - T568A and T568B universal wiring - 8 contacts - anti-dust lid integrated in the connector - 1 module</i></p>	1	10
		<p>□ <b>441029C6S</b></p> <p>Priključnica 3M RJ45 kategorija 6 FTP - oklopljena - žabice za brzo spajanje kabela bez alata - T568A i T568B - 8 kontakata - poklopac protiv prašine ugrađen na konektor - 1 modul  <i>RJ45 category 6 outlet - shuttered - 3M connector - insulation piercing terminals with rapid wiring - T568A and T568B universal wiring - 8 contacts - anti-dust lid integrated in the connector - 1 module</i></p>	1	10

**Napomena:** na gornjem delu priključnice nalazi se prozorčić sa karticom za ispisivanje oznake instalirane priključnice

**Note:** on the upper part there is a transparent glass with card to allow the installer/user to identify the type of outlet

## Adapteri za RJ45 priključnice    Adaptors for RJ45 connectors

Domus	Opis	Description	Info	€
	<b>441029SC</b>	<p>□ <b>441029SC</b></p> <p>Adapter za priključnice RJ45 3M, AT&amp;T, CEAM-QUBIX, KRONE, CLIPSAL, AMPHENOL, FANTON ili priključnice AVE RJ11, RJ45, RCA, TV, itd. - 1 modul  <i>Adaptor for RJ45 3M, AT&amp;T, CEAM-QUBIX, KRONE, CLIPSAL, AMPHENOL, FANTON or AVE RJ11, RJ45, RCA, TV, etc. connectors - 1 module</i></p>	4	4
	<b>441030SC</b>	<p>□ <b>441030SC</b></p> <p>Adapter za priključnice RJ45 AMP, RSX, BRAND-REX - 1 modul  <i>Adaptor for RJ45 AMP, RSX, BRAND-REX connectors - 1 module</i></p> <p><b>Napomena:</b> na gornjem delu adaptera nalazi se prozorčić sa karticom za ispisivanje oznake instalirane priključnice</p> <p><b>Note:</b> on the upper part there is a transparent glass with card to allow the installer/user to identify the type of outlet</p>	4	4





# Serija DOMUS Touch

DOMUS Touch series





Direktna TV priključnica Ø 9,5 mm  
Direct TV outlet Ø 9,5 mm



116

Domus	Opis	Description	Info	€
 441091	<input type="checkbox"/> 441091	Direktna TV priključnica rezistivna sa ženskim IEC 60169-2 konektorom - frekventni opseg 40÷862 MHz - dolazni priključak sa stezaljkom za šraf - 1 modul Direct TV outlet with IEC 60169-2 female connector - frequency range 40÷862 MHz - incoming connection with screw terminal - 1 module	Δ 	1 10
<b>Napomena:</b> koristi se samo u zemljama koje nisu članice EU <b>Note:</b> the outlet must be used only in non-EU Countries				

## TV/SAT koaksijalne priključnice sa CAP - Ø 9,5 mm - Pribor TV/SAT coaxial outlets - Ø 9,5 mm - Accessories

Domus	Opis	Description	Info	€
 441096IM	<input type="checkbox"/> 441096IM	Direktna TV/SAT koaksijalna priključnica sa muškim IEC 60169-2 konektorom za frekvencije do 2400 MHz - dolazni priključak sa muškim F konektorom - u kompletu sa plastičnom kapičom (CAP) za priključak koaksijalnog kabl - u kompletu sa nalepnicama TV/SAT - 1 modul TV/SAT direct coaxial outlet with IEC 60169-2 male connector for frequencies until 2400 MHz - incoming connection through F male connector - supplied with moulded connector (CAP) for coaxial cable connection - supplied with sticky labels TV/SAT - 1 module		2 12
 441096F	<input type="checkbox"/> 441096F	Direktna TV/SAT koaksijalna priključnica sa ženskim F konektorom za frekvencije do 2400 MHz - dolazni i odlazni priključak sa muškim F konektorom - u kompletu sa plastičnom kapičom (CAP) za priključak koaksijalnog kabl - u kompletu sa nalepnicama TV/SAT - 1 modul TV/SAT direct coaxial outlet with F female connector for frequencies until 2400 MHz - incoming and outgoing connection through F male connector - supplied with moulded connector (CAP) for coaxial cable connection - supplied with sticky labels TV/SAT - 1 module		2 12
 441096IF	<input type="checkbox"/> 441096IF	Direktna TV/SAT koaksijalna priključnica sa ženskim IEC 60169-2 konektorom za frekvencije do 2400 MHz - dolazni priključak sa muškim F konektorom - u kompletu sa plastičnom kapičom (CAP) za priključak koaksijalnog kabl - u kompletu sa nalepnicama TV/SAT - 1 modul TV/SAT direct coaxial outlet with IEC 60169-2 female connector for frequencies until 2400 MHz - incoming connection through F male connector - supplied with moulded connector (CAP) for coaxial cable connection - supplied with sticky labels TV/SAT - 1 module		2 12
 TVDER-DB6 TVDER-DB10 TVDER-DB14	<b>TVDER-DB6</b>	TV/SAT induktivni razdelnik - povezuje se na priključnice 441096IM, 441096IF, 441096F - prolazno slabljenje 6dB TV/SAT inductive shunt to be connected to 441096IM, 441096IF, 441096F - attenuation 6dB		1 6
	<b>TVDER-DB10</b>	TV/SAT induktivni razdelnik - povezuje se na priključnice 441096IM, 441096IF, 441096F - prolazno slabljenje 10dB TV/SAT inductive shunt to be connected to 441096IM, 441096IF, 441096F - attenuation 10dB		1 6
	<b>TVDER-DB14</b>	TV/SAT induktivni razdelnik - povezuje se na priključnice 441096IM, 441096IF, 441096F - prolazno slabljenje 14dB TV/SAT inductive shunt to be connected to 441096IM, 441096IF, 441096F - attenuation 14dB		1 6
<b>Napomena:</b> TVDER-DB... omogućava da se direktne priključnice 441096IM, 441096IF, 441096F pretvore u prolazne <b>Note:</b> TVDER-DB... allow to change the 441096IM, 441096IF, 441096F outlets from direct to through line				



Za raspoloživost kontaktirajte Ave distributere  
For availability please contact sales dept.



Dostupni dok se ne rasprodaju zalihe  
Available until stock out



Proizvod za pravougaone kutije britanskog standarda  
Product for British standard rectangular box



Proizvod za izvoz  
For Export only



## Kompleti za TV instalacije KIT for TV installations

Domus	Opis Description	Info	€
 <b>TVKIT</b>	<b>TVKIT</b> Komplet pribora za TV/SAT instalacije. Pakovanje sadrži: 110 plastičnih kapica CAP za priključivanje koaksijalnog kabla; 15xTVGC nastavaka za koaksijalne kablove; 15xTVSPIM TV/SAT završetaka koaksijalnog kabla sa muškim IEC konektorom; 15xTVSPIF TV/SAT završetaka koaksijalnog kabla sa ženskim IEC konektorom; 15xTVSPF TV/SAT završetaka koaksijalnog kabla sa muškim F konektorom; 1xTVSP univerzalna blankerica za koaksijalne kablove; 1xTVPZ kješta za montažu plastičnih kapica CAP. <i>Complete Kit accessories for TV/SAT installations.</i> <i>The box includes: n° 110 CAP plastic connectors for coaxial cables;</i> <i>n° 15 TVGC shuttered connectors for cable junction;</i> <i>n° 15 TVSPIM free plugs TV/SAT shuttered IEC male;</i> <i>n° 15 TVSPIF free plugs TV/SAT shuttered IEC female;</i> <i>n° 15 TVSPF free plugs TV/SAT shuttered F male;</i> <i>n° 1 TVSP coaxial cable universal peeler</i> <i>n° 1 TVPZ plier for cap installation</i>	1	1

### TV/SAT koaksijalna priključnica Ø9,5 mm TV/SAT coaxial outlet Ø 9,5 mm

Domus	Opis Description	Info	€
 <b>441096M</b>	<b>□ 441096M</b> Direktna TV/SAT koaksijalna priključnica sa muškim IEC 60169-2 konektorom za frekvencije do 4÷2400 MHz - prolazno slabljenje 1dB - dozvoljava prolaz jednosmerne struje i kontrolnih signala (24V 300mA max) - dolazni priključak sa stezaljkama sa šrafo - u kompletu sa nalepnicama TV/SAT - 1 modul <i>Direct TV/SAT outlet with male IEC 60169-2 connector - for frequencies 4÷2400 MHz - attenuation 1dB - it allows the passage of direct current and control signals (24V 300mA max) input attachment through screw terminals - supplied with TV/SAT adhesive labels - 1 module</i>	1	10

### Kombinovane TV/FM i TV/SAT/FM priključnice TV/SAT outlets with 2 and 3 connectors

Domus	Opis Description	Info	€
 <b>441096/2PU</b>	<b>□ 441096/2PU</b> Direktna TV/FM priključnica sa muškim IEC 60169-2 konektorom za frekvencije do 4÷2400 MHz - prolazno slabljenje 5dB - dozvoljava prolaz jednosmerne struje i kontrolnih signala (24V 300mA max) kroz ženski konektor - dolazni priključak sa stezaljkama sa šrafo - 1 modula <i>Direct TV-FM/SAT duplex outlet with IEC 60169-2 male and female connectors - frequency range 4÷2400 MHz - Attenuation 5 dB - it allows the passage of direct current and control signals (24V 300mA max) through the female connector - Incoming connection with screw terminal - 2 modules</i>	1	6
 <b>441096/3PU</b>	<b>□ 441096/3PU</b> Direktna TV/FM/SAT priključnica sa IEC 60169-2 muškim TV konektorom, IEC 60169-2 sa ženskim radio konektorom i ženskim SAT F konektorom - frekventni opseg 4÷2400 MHz - slabljenje 1dB - dozvoljava prolaz jednosmerne struje i kontrolnih signala (24V 300mA max) kroz ženski F konektor - dolazni priključak sa stezaljkama sa šrafo - 2 modula <i>Direct TV-FM/SAT triplex outlet with IEC 60169-2 male TV connector, IEC 60169-2 female radio connector and SAT female F-type connector - frequency range 4÷2400 MHz - Attenuation 1dB - it allows the passage of direct current and control signals (24V 300mA max) through the female F-type connector - incoming connection with screw terminal - 2 modules</i> <b>Napomena:</b> 441096/3PU za optimalan rad utičnice treba koristiti sve izlaze <b>Note:</b> 441096/3PU for a perfect functioning of the outlet, all the connectors must be used	1	6

### TV/SAT priključnice TV/SAT Sockets

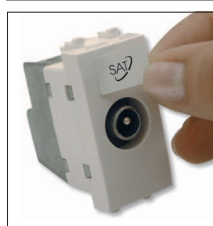

Postavljanje nalepnice sa oznakom

Application of sticky label for diversification TV/SAT

Min. pakovanje kom.  
Min. Packaging pcs

Stand. pakovanje kom.  
Std. Packaging pcs









# Serija DOMUS Touch

DOMUS Touch series



Pribor za TV instalacije  
Accessories for TV coaxial outlets

118

	Opis	Description	Info	€
 CAP	 TVSPIM	<b>CAP</b> Plastični konektor (kapica) za koaksijalne kablove - omogućava brzo i jeftino povezivanje - koristi se sa priključnicama 44..096F, 44..096IM, 44..096IF <i>Plastic connector for coaxial cables - it allows a fast and cheap connection - to be used with 44..096F, 44..096IM, 44..096IF sockets</i>	50	50
 TVSPIF	 TVSPF	<b>TVGC</b> Konektor za nastavljane koaksijalnih kablova za frekvencije do 2400 MHz - konektori F ženski/F ženski - u kompletu sa 2 plastične kapice (CAP) <i>Shuttered junction connector for cables for frequencies up to 2400 MHz F female-F female connectors - supplied with n. 2 plastic connectors (CAP)</i>	50	50
 TVGC		<b>TVSPIM</b> Završetak koaksijalnog kabla sa muškim IEC konektorom TV/SAT z - za frekvencije do 2400MHz- u kompletu sa 1 plastičnom kapičom (CAP) <i>Shuttered TV/SAT movable plug for frequencies up to 2400 MHz Male IEC connector - supplied with n.1 plastic connector (CAP)</i>	50	50
 TVSPIF		<b>TVSPIF</b> Završetak koaksijalnog kabla sa ženskim IEC konektorom (TV/SAT) za frekvencije do 2400 MHz -u kompltu sa 1 plastičnom kapičom (CAP) <i>Shuttered TV/SAT movable plug for frequencies up to 2400 MHz Female IEC connector - supplied with n.1 plastic connector (CAP)</i>	50	50
 TVFST		<b>TVSPF</b> Završetak koaksijalnog kabla sa muškim F konektorom (TV/SAT) - za frekvencije do 2400MHz- u kompletu sa 1 plastičnom kapičom (CAP) <i>Shuttered TV/SAT movable plug for frequencies up to 2400 MHz F male connector - supplied with n.1 plastic connector (CAP)</i>	50	50
 TVFST		<b>TVFST</b> Univerzalna vezica za fiksiranje kablova/cevi prečnika 0,5÷32 mm <i>Universal band for 0,5÷32 mm cables/ducts fixing</i>	100	100
 TVPZ		<b>TVPZ</b> Klješta za montažu plastičnih kapičica CAP - olakšava postavljanje i skidanje kapičica CAP sa ženskih F konektora <i>Pliers for CAP fixing operations - it simplifies the operations of the CAP inserting and pulling out on F female connectors</i>	1	10

## CAP

### POVEZIVANJE CONNECTION

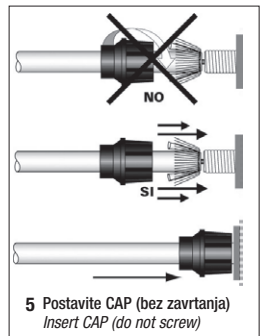
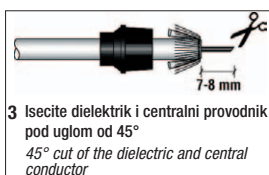
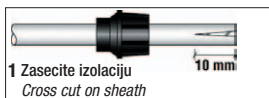

### Izvlačenje EXTRACTION

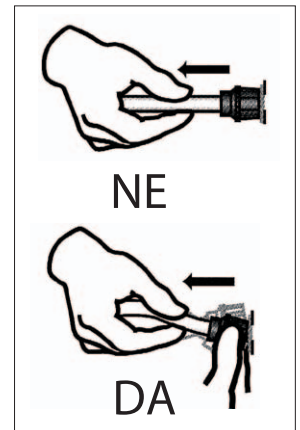

Za raspoloživost kontaktirajte Ave distributere  
For availability please contact sales dept.



Dostupni dok se ne rasprodaju zalihe  
Available until stock out







Proizvod za pravougaone kutije britanskog standarda  
Product for British standard rectangular box



Proizvod za izvoz  
For Export only

## Signalni konektori Connectors

	Opis <i>Description</i>	Info	€
 <b>CBNCF</b>	<b>CBNCF</b> AVE BNC ženski konektor - dolazni priključak preko muškog F konektora - za video signal niskih frekvencija - najčešća primena za povezivanje CCTV uređaja i dekodera - u kompletu sa plastičnom kapičom CAP za povezivanje kabla - može se postaviti na adapter 44..029SC <i>AVE BNC female connector - input connection through F-type male connector - for low frequency video connections - typical use for TVCC and decoder connections - supplied with (CAP) plastic connector - installable on adaptor code 44..029SC</i>	5	5
 <b>CRCAF</b>	<b>CRCAF</b> AVE RCA ženski konektor - dolazni priključak preko muškog F konektora - za audio signal niskih frekvencija - najčešća primena za povezivanje zvučnika - u kompletu sa plastičnom kapičom CAP za povezivanje kabla - može se postaviti na adapter 44..029SC <i>AVE RCA female connector - input connection through F-type male connector - for low frequency audio connections - typical use for loudspeaker connections - supplied with (CAP) plastic connector - installable on adaptor code 44..029SC</i>	5	5
 <b>CRJ11T</b>	<b>CRJ11T</b> AVE RJ11 konektor (4 kontakta) - žabice za brzo povezivanje kabla bez alata - može se postaviti na adapter 44..029SC <i>AVE RJ11 connector (4 contacts) - insulation piercing terminals with rapid wiring - installable on adaptor code 44..029SC</i>	5	5
 <b>CRJ45C5E</b>	<b>CRJ45C5E</b> AVE RJ45 priključnica kategorije 5e - neoklopljena - žabice za spajanje kabla uz pomoć alata - brzo kabliranje pomoću priloženog alata - univerzalno kabliranje T568A i T568B standard - 8 kontakata - može se postaviti na adapter 44..029SC <i>AVE RJ45 category 5 enhanced connector - not shuttered - insulation piercing terminals - supplied with accessory for rapid wiring - T568A and T568B universal wiring - 8 contacts - installable on adaptor code 44..029SC</i>	5	5

### Ave signalni konektori Ave Connectors

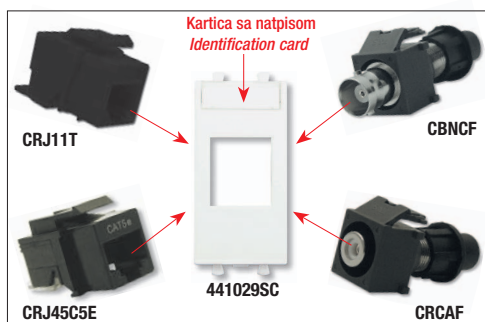

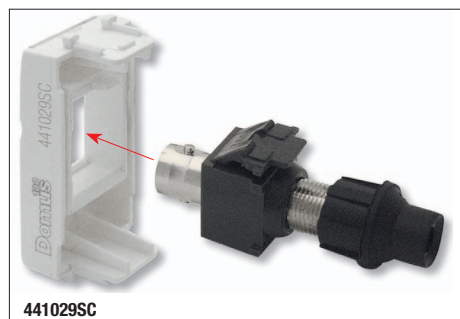

Svi konektori se postavljaju na isti adapter 441029SC  
*All the connectors can be installed on the adapter - code 441029SC*

Kačenje konektora i adaptera  
*Connector clipping to the adapter*



### Automatski magnetotermički osigurači 120-230V~ MCBs 120-230V~

Domus	Opis <i>Description</i>	Info	€
 <b>441052X6</b>	<b>441052X6</b> Automatski magnetotermički osigurač 1P+N 6A 120-230V~ prekidni kapacitet 1,5kA - disipacija 1,2W - 1 modul <i>MCB 1P+N 6A 120-230V~ b.c. 1,5kA - dissipated power 1,2W - 1 module</i>	1	10
 <b>441052X10</b>	<b>441052X10</b> Automatski magnetotermički osigurač 1P+N 10A 120-230V~ prekidni kapacitet 3kA - disipacija 1W - 1 modul <i>MCB 1P+N 10A 120-230V~ b.c. 3kA - dissipated power 1W - 1 module</i>	1	10
 <b>441052X16</b>	<b>441052X16</b> Automatski magnetotermički osigurač 1P+N 16A 120-230V~ prekidni kapacitet 3kA - disipacija 2,1W - 1 modul <i>MCB 1P+N 16A 120-230V~ b.c. 3kA dissipated power 2,1W - 1 module</i>	1	10

U skladu sa normom IEC 60898  
*In conformity with IEC 60898 standard*

**Napomena:** Osigurači sa C krivinom prekidanja

**Note:** MCB type C

Min. pakovanje kom.  
 Min. Packaging pcs

Stand. pakovanje kom.  
 Std. Packaging pcs



# Serija DOMUS Touch

DOMUS Touch series



## Diferencijalna (FID) sklopka sa automatski osiguračem 120-230V~ RCBOs 120-230V~



120

Domus	Opis	Description	Info	€
 <p><b>441062X6</b> <b>441062X10</b> <b>441062X16</b></p> <p>U skladu sa normom IEC 61009 In conformity with IEC 61009 standard</p>	<input type="checkbox"/> <b>441062X6</b>	Diferencijalna (FID) sklopka sa automatskim magnetotermičkim osiguračem 1P+N 6A 120-230V~ $I_{\Delta n}$ 10mA prekidni kapacitet 1,5kA - disipacija 1,3W - 2 modula RCBO 1P+N 6A 120-230V~ $I_{\Delta n}$ 10mA b.c.1,5kA - dissipated power 1,3W - 2 modules	1	6
	<input type="checkbox"/> <b>441062X10</b>	Diferencijalna (FID) sklopka sa automatskim magnetotermičkim osiguračem 1P+N 10A 120-230V~ $I_{\Delta n}$ 10mA prekidni kapacitet 3kA - disipacija 1,1W - 2 modula RCBO 1P+N 10A 120-230V~ $I_{\Delta n}$ 10mA b.c. 3kA - dissipated power 1,1W - 2 modules	1	6
	<input type="checkbox"/> <b>441062X16</b>	Diferencijalna (FID) sklopka sa automatskim magnetotermičkim osiguračem 1P+N 16A 120-230V~ $I_{\Delta n}$ 10mA prekidni kapacitet 3kA - disipacija 2,5W - 2 modula RCBO 1P+N 16A 120-230V~ $I_{\Delta n}$ 10mA b.c. 3kA - dissipated power 2,5W - 2 modules	1	6
<p><b>Note:</b> ✓ signalizacija preko indikatora mrežnog napajanja sa prednje strane i zatvorenog kontakta preko zelene LED lampice ✓ osigurači sa C krivinom prekidanja - diferencijalne sklopke tip A</p> <p><b>Notes:</b> ✓ frontal signal of power supply and closed contact through a green led ✓ MCB type C - RCBO type A</p>				

## Diferencijalna (FID) sklopka 120-230V~ RCCBs 120-230V~

Domus	Opis	Description	Info	€
 <p><b>441062X16/30MA</b></p> <p>U skladu sa normom IEC 61008 In conformity with IEC 61008 standard</p>	<input type="checkbox"/> <b>441062X16/30MA</b>	Diferencijalna (FID) sklopka 2P 16A 120-230V~ $I_{\Delta n}$ 30mA - disipacija 2,5W - 2 modula RCCB 2P 16A 120-230V~ $I_{\Delta n}$ 30mA - dissipated power 2,5W - 2 modules	1	6
<p><b>Note:</b> ✓ signalizacija preko indikatora mrežnog napajanja sa prednje strane i zatvorenog kontakta preko zelene LED lampice ✓ osigurači sa C krivinom prekidanja - diferencijalne sklopke tip A</p> <p><b>Notes:</b> ✓ frontal signal of power supply and closed contact through a green led ✓ RCBO type A</p>				

## Nosači osigurača 250V~ Fuse Holders 250V~

Domus	Opis	Description	Info	€
 <p><b>441007</b></p>	<input type="checkbox"/> <b>441007</b>	Nosač minijaturnih osigurača 1P 16A - za osigurače $\emptyset$ 5x20 mm - isporučuje se bez osigurača - 1 modul Fuse holder for miniature fuses 1P 16A - for fuses $\emptyset$ 5x20 mm - supplied without fuse - 1 module	1	10
	<input type="checkbox"/> <b>441007/13A</b>	Nosač osigurača tipa BS1362 1P 13A - za osigurače $\emptyset$ 6,3x28 mm - isporučuje se u kompletu sa osiguračem - 1 modul Fuse holder for BS1362 fuse 1P 13A - for fuses $\emptyset$ 6,3x28 mm - supplied with fuse - 1 module	1	10
 <p><b>441007/13A</b></p>				



Za raspoloživost kontaktirajte  
Ave distributere  
For availability please contact  
sales dept.



Dostupni dok se ne  
rasprodaju zalihe  
Available until stock out



Proizvod za pravougaone  
kutije britanskog standarda  
Product for British standard  
rectangular box



Proizvod za  
izvoz  
For Export  
only

## Relaj za pozivni SOS sistem Relays

Domus	Opis Description	Info	€
-------	---------------------	------	---

121



441087C

### □ 441087C

1 6

Statički bistabilni relaj (tipa Flip-Flop SR) 12Vac/dc za pozivne sisteme - 2 izlaza: za svetlosnu signalizaciju (trepereću ili stalnu) i za zvučnu signalizaciju (kontinuirani zvuk ili u intervalima od 3 sekunde do 1 minuta) - aktiviranje i resetovanje alarma sa više udaljenih lokacija pomoću paralelno vezanih NO tastera - 1 modul

*Static bistable relay (type Flip-Flop SR) 12Vca/cc for call systems - 2 outputs: for visual signals (flashing or fixed) and acoustic signals (continuous sound or at intervals of 3 seconds to 1 minute) - activated and silenced from various points using normal NO push buttons connected in parallel - 1 module*

**Nota:** za pravilan rad releja neophodno je predvideti transformator 12Vac ili napajanje 12dc odgovarajuće dimenzionisano

**Note:** For the proper functioning of the relay it is necessary to provide a transformer 12Vac or a power supply 12Vdc appropriately sized

Šema povezivanja 441087C Connection Diagram 441087C

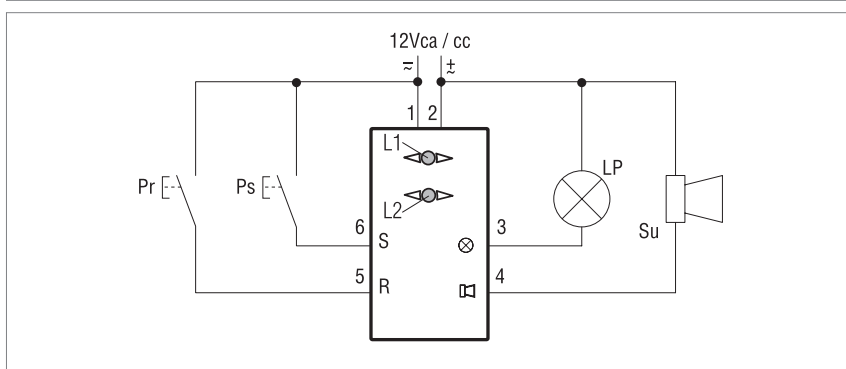

### Pozivni sistem - Upotreba releja za pozivni sistem Call Relay – Call System

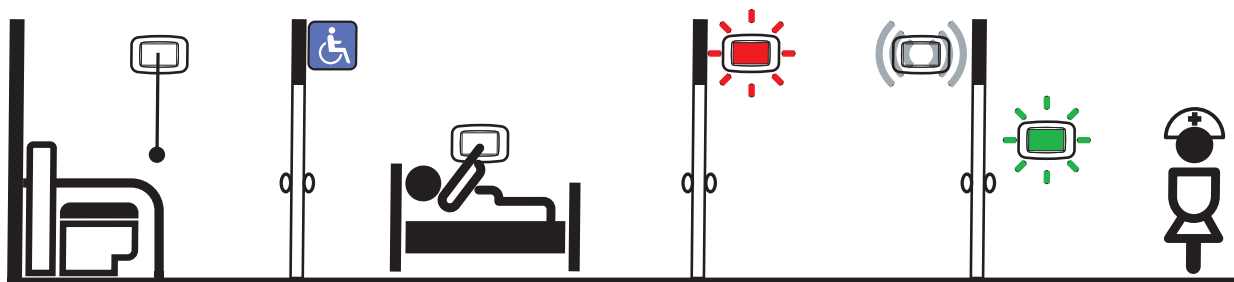

Pritiskom na taster, pacijent vrši poziv. Relaj aktivira svetlosnu i zvučnu signalizaciju u hodniku kao i svetlosnu signalizaciju na recepciji koja odgovara borju poziva  
By pressing a push button the patient makes a call. The relay activates the visual and sound signals in the corridor and the visual signal at reception corresponding to the caller's number



Medicinska sestra po dolasku u sobu pacijenta može resetovati alarm pritiskom na odgovarajući reset taster, poništavajući tako optičku i akustičnu signalizaciju.  
The nurse is summoned to the patient's room and can reset by pressing the push button in the room, cancelling the visual and sound signals.

□ Min. pakovanje kom.  
Min. Packaging pcs

□ Stand. pakovanje kom.  
Std. Packaging pcs







# Serie DOMUS Touch

DOMUS Touch series





Elektromehanička zvana i zujalice  
Bells / Buzzers





122

Domus	Descrizione Description	Info	€
 441028	<input type="checkbox"/> 441028 Zvono 12V~ 8VA (SELV) - 1 modul Ringing bell 12V~ 8VA (SELV) - 1 module	1	10
 441030	<input type="checkbox"/> 441029 Zvono 230V~ - 1 modul Ringing bell 230V~ - 1 module	1	10
 441031	<input type="checkbox"/> 441030 Zujalica 12V~ 8VA (SELV) - 1 modul Buzzer 12V~ 8VA (SELV) - 1 module	1	10
 441031	<input type="checkbox"/> 441031 Zujalica 230V~ - 1 modul Buzzer 230V~ - 1 module	1	10

## Elektronska zvana Electronic bells

Domus	Opis Description	Info	€
 441081	<input type="checkbox"/> 441081 Pomoćni signalizator alarma sa mogućnošću podešavanja tajmera zvona u intervalu 5-12s u funkciji napona napajanja - napajanje 12-24 Vac/dc - mogućnost podešavanja inteziteta zvuka - zvučni pritisak 86dB na 1m - LED signalizacija sa prednje strane - 1 modula Auxiliary alarm signal - possibility of setting a timer to ring for 5s-12s depending on input voltage- input 12-24 Vac/dc - it is possible to adjust the sound volume - acoustic pressure 85 dB at 1m - front signalling led - 1 module	1	10
 441083	<input type="checkbox"/> 441083 Trotonsko elektronsko zvono - napajanje 12 Vac/dc - mogućnost izbora jednog od šest različitih melodija - mogućnost podešavanja inteziteta zvuka sa prednje strane - LED signalizacija sa prednje strane - zvučni pritisak 68÷74 dB na 1m u zavisnosti od odabrane vrste tona - 1 modul Three tone electronic bell - 12 Vac/dc power supply - possibility to choose one out of six acustics tones - frontal sound regulation - frontal signalling led - acoustic pressure 68÷74 dB at 1 m according to the sound activated - 1 module	1	10
 441083/2	<input type="checkbox"/> 441083/2 Trotonsko elektronsko zvono - napajanje 12 Vac/dc - mogućnost izbora jednog od šest različitih melodija - mogućnost podešavanja inteziteta zvuka sa prednje strane - LED signalizacija sa prednje strane - zvučni pritisak 71-76 dB na 1m u zavisnosti od odabrane vrste tona - 2 modula Three tone electronic bell - 12 Vac/dc power supply - possibility to choose one out of six acustics tones - frontal sound regulation - frontal signalling led - acoustic pressure 71÷76 dB at 1 m according to the sound activated - 2 modules	1	6
 AF441099	<input type="checkbox"/> AF441099 Pomoćna sirena za protivprovalne sisteme ili zvučnu signalizaciju - napajanje 12Vdc - mogućnost podešavanja 2 nivoa jačine zvuka - mogućnost izbora jednog od tri tona- zvučni pritisak 90dB na 3m - isporučuje se u kompletu sa nalepnicom ALARM - 2 modula Indoor siren for burglar alarm systems or acoustical device - 12 Vdc power supply - possibility to set two different levels of acoustic intensity - possibility to choose among three different acoustic sounds - acoustic pressure 90 dB at 3m - 2 modules	1	1

## Stepenišna svetiljka i prenosiva baterijska svetiljka Step marker light and removable portable lamp

Domus	Descrizione Description	Info	€
 441070/1	<input type="checkbox"/> 441070/1 Stepenišna svetiljka - napajanje 12-24 Vac/dc o 230 V~ - LED lampica bele boje visoke efikasnosti - 1 modul Step marker light - input 12-24 Vac/dc o 230 V~ - white led, high efficiency - 1 module	1	10
 441086	<input type="checkbox"/> 441086 Prenosiva panik svetiljka sa bazom za punjenje - u kompletu sa punjivom baterijom koja se može zameniti - svetiljka: LED bele boje visoke efikasnosti - prekidač sa prednje strane za isključivanje u slučaju nestanka mrežnog napajanja - vreme punjenja 36 sati - automonija oko 3 sata - napajanje 110÷230V~ - 2 modula Anti black out removable portable lamp - with recharging base - with interchangeable and rechargeable batteries - lamp: high efficiency white led - front switch in case of power failure - 36 hours recharge time - 3 hours endurance - 110÷230 V~ power supply - 2 module	1	1
 45786B	<input type="checkbox"/> 45786B Rezervna baterija (4x1,2)V - 80mAh, za uređaj 441086 Spare battery for 441086 (4x1,2)V - 80mAh	1	1



Za raspoloživost kontaktirajte Ave distributere  
For availability please contact sales dept.



Dostupni dok se ne rasprodaju zalihe  
Available until stock out





Proizvod za pravougaone kutije britanskog standarda  
Product for British standard rectangular box

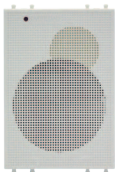

Proizvod za izvoz  
For Export only

## Sistem ozvučenja Sound diffusion

Domus	Opis <i>Description</i>	Info	€
 441AP01	<p>□ 441AP01</p> <p>Zvučnik - impedansa 8 Ohm - snaga 5W - zaštita od preopterećenja sa signalizacijom pomoću LED lampice - isporučuje se u kompletu sa dva spoljašnja okvira bele boje Ral 9010 koji se koriste sa maskama 6 (3+3) modula: jedan je za maske Zama/Personal 44 (44P933... - 44P033...) a drugi je za maske Vera 44 (44PV33...-44PA33...-44PL33...). Okvir se mora postaviti na odgovarajuću masku nakon skidanja originalnog okvira sa prečkom po sredini koja je isporučena sa maskom - može se koristiti i hromirani okvir 44CRV33CR/AP (za maske Vera 44) ili 44CR33CR/AP (za maske Zama/Personal 44) - instalacija sa armaturom 44A33 u</p> <p><i>Loudspeaker - 8 Ohm impedance - 5W power - overload protection with LED indication - supplied with inner frames white Ral 9010 for use with plates 6(3+3) modules: one inner frame for Zama/Personal 44 plates (44P933.. - 44P033..) and one for Vera 44 plates (44PV33.. - 44PA33.. -44PL33..). The inner frame must be installed after removing the original one supplied with the plate with the central crossbar - possibility to use chrome inner frame 44CRV33CR/AP (for Vera44 plates) or 44CR33CR/AP (for Zama/Personal44 plates) - installation with 44A33 frame in BL02P flush mounted box</i></p>	1	1
 441DS01	<p>□ 441DS01</p> <p>Mono regulator nivoa zvuka za zvučnike - omogućava podešavanje nivoa zvuka svakog pojedinačnog zvučnika (levi ili desni kanal) bez vršenja uticaja na druge zvučnike koji su instalirani na istom sistemu - podešavanje u 6 pozicija: (OFF, 1, 2, 3, 4, 5) - 2 modula</p> <p><i>Mono volume controller for loudspeakers - It allows the control of an individual loudspeaker (left or right channel) with no interference on the volume of other loudspeakers installed in the same plant - regulation with 6 positions (OFF, 1, 2, 3, 4, 5) - 2 modules</i></p>	1	1
 441DS02	<p>□ 441DS02</p> <p>Stereo regulator nivoa zvuka za zvučnike - omogućava istovremeno podešavanje nivoa zvuka jednog para zvučnika (desni i levi kanal) bez vršenja uticaja na druge parove zvučnika koji su instalirani na istom sistemu - podešavanje u 6 pozicija: OFF, 1, 2, 3, 4, 5 - u kompletu sa armaturom za kutiju 2503MG - 3 modula</p> <p><i>Stereo volume controller for loudspeakers - It allows simultaneous control of a pair of loudspeakers (left and right channels) with no interference on the volume of other pairs of loudspeakers installed in the same plant. Regulation with 6 positions (OFF, 1, 2, 3, 4, 5) - complete with frame for 2503MG box - 3 modules</i></p>	1	1



### Primer upotrebe sistema ozvučenja *Sound diffusion application example*

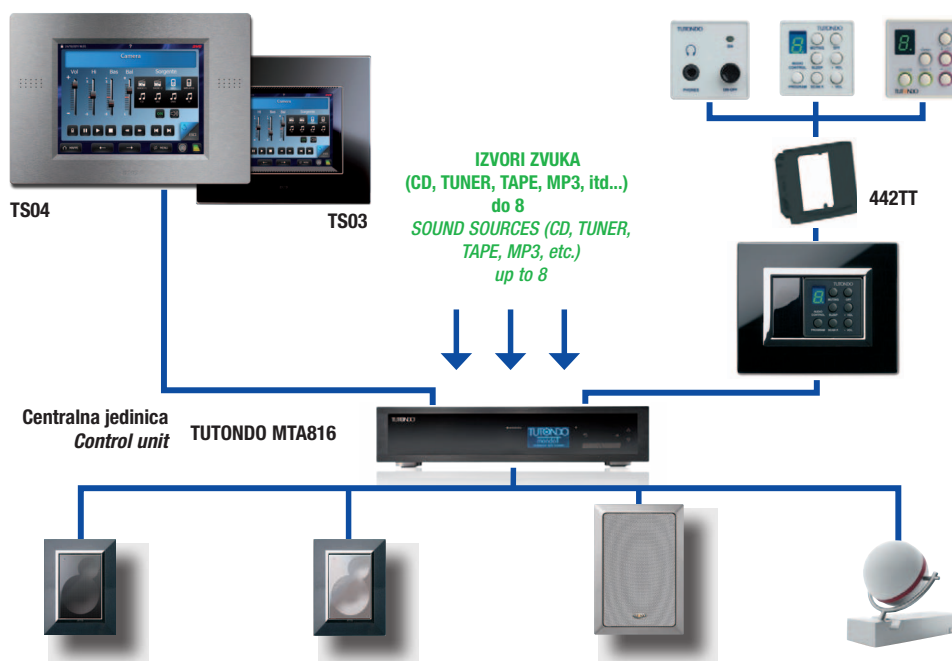









# Serija DOMUS Touch

DOMUS Touch series

Optička signalizacija  
Optical signals

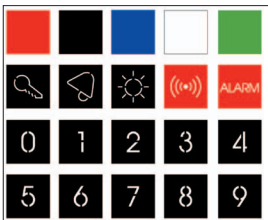

124

Opis	Description	Info	€
 442037RS	442037RS Noslač lampice sa crvenim difuzorom - u kompletu sa izmenljivim karticama sa simbolima - 1 modul <i>Lampholder with red diffuser- supplied with interchangeable labels and insert lenses - 1 module</i>	1	10
 442037TR	442037TR Noslač lampice sa providnim difuzorom - u kompletu sa izmenljivim karticama sa simbolima - 1 modul <i>Lampholder with transparent diffuser- supplied with interchangeable labels and insert lenses - 1 module</i>	1	10
 442037VE	442037VE Noslač lampice sa zelenim difuzorom - u kompletu sa izmenljivim karticama sa simbolima - 1 modul <i>Lampholder with green diffuser - supplied with interchangeable labels and insert lenses - 1 module</i>	1	10
 442067	442067 Dvostruki noslač lampice sa crvenim/zelenim difuzorom - u kompletu sa izmenljivim karticama sa simbolima - 1 modul <i>Twin lampholder with red/green diffuser - supplied with interchangeable insert lenses - 1 module</i>	1	10
 442076	442076 Ispučeni noslač lampice (ispred vrata) sa crvenim difuzorom - za lampice 10x28 mm sa grlom E10 230V~ 3W max - 2 modula <i>Prominent lampholder (outside door)with red diffuser - for E10 10x28 mm 230V~ 3W max lamps - 2 modules</i>	1	6
 442076VE	442076VE Ispučeni noslač lampice (ispred vrata) sa zelenim difuzorom - za lampice 10x28 mm sa grlom E10 230V~ 3W max - 2 modula <i>Prominent lampholder (outside door) with green diffuser - for E10 10x28 mm 230V~ 3W max lamps - 2 modules</i>	1	6
 ET120	ET120 Komplet od 20 izmenljivih kartica sa simbolima za nosače lampica - različiti stil i simboli <i>Set of 20 interchangeable labels for lampholders - different words and symbols</i>	1	1

**Novo**

**Napomena:** nosači lampica isporučuju se bez signalnih lampica

**Note:** lampholders are supplied without signalling lamp

## Signalne lampice Optical Signals

### Postupak montaže

### Assembly Procedure

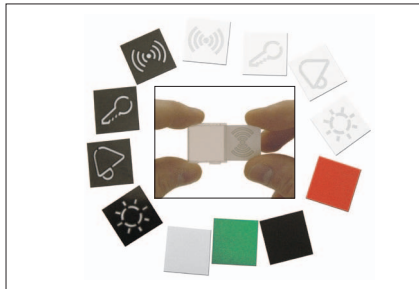

1. Odaberite željenu karticu i postavite je sa zadnje strane difuzora  
*Select the label and place it in the back of the diffuser*

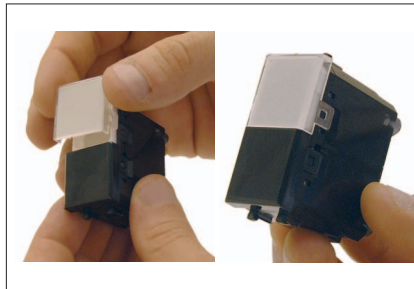

2. Postavite difuzor na njegovu bazu  
*Place the diffuser on its base*

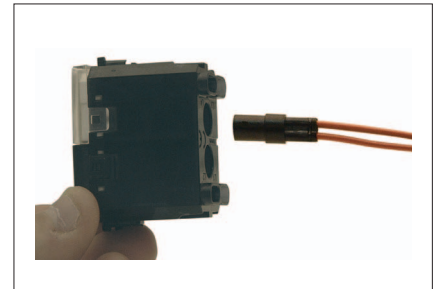

3. Sa zadnje strane postavite signalnu lampicu  
*Introduce the signalling lamp from the back*

### Nekoliko primera lampica

### A few Examples of customization

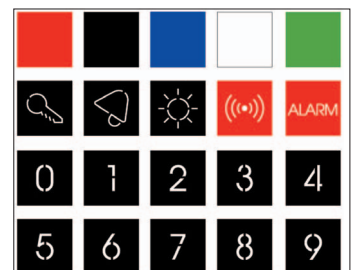

ET120 Komplet od 20 izmenljivih kartica  
ET120 Set of 20 interchangeable labels



Za raspoloživost kontaktirajte Ave distributere  
For availability please contact sales dept.



Dostupni dok se ne rasprodaju zalihe  
Available until stock out



Proizvod za pravougaone kutije britanskog standarda  
Product for British standard rectangular box



Proizvod za izvoz  
For Export only

## Signalne lampice E10 E10 signalling lamps

Opis	Description	Info	€
 0212LDW/E10 0212LDW/E10HI 0230LDW/E10	<b>0212LDW/E10</b> LED lampica 12V~ E10 10x22 mm - bele boje - koristi se sa tasterom sa pozadinskim osvetljenjem za karticu sa imenom 441005TP/2 i 442005TP/2 <i>LED lamp 12V~ E10 10x22 mm - white colour - to be used with name tag code 441005TP/2 and 442005TP/2</i>	10	10
<b>0212LDW/E10HI</b> LED lampica visokog inteziteta 12V~ E10 10x22 mm - bele boje - koristi se sa ispuščenim nosačem lampica 442076 <i>High intensity led lamp 12V~ E10 10x22 mm - white colour - to be used with prominent lampholder code 442076</i>	10	10	
<b>0230LDW/E10</b> LED lampica 230V~ E10 10x22 mm - bele boje - koristi se sa tasterom sa pozadinskim osvetljenjem za karticu sa imenom 441005TP/2 i 442005TP/2 ili sa ispuščenim n nosačem lampica 442076 <i>LED lamp 230V~ E10 10x22 mm - white colour - to be used with - to be used with name tag push buttons code 441005TP/2 and 442005TP/2 or with prominent lampholder code 442076</i>	10	10	



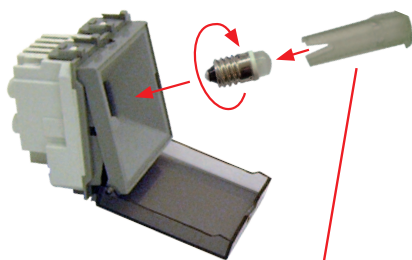



### Instalacija signalne lampice E10 E10 signalling lamp installation



Dodatna oprema u kompletu sa lampicom  
Accessory supplied with the lamps

## Signalne lampice

## Signalling lamps

Opis	Description	Info	€
 0224 0212LDW 0230LDW	<b>0212LDB</b> LED lampica 12-24Vac/dc niske potrošnje - plave boje <i>Low consumption 12-24Vac/dc led lamp - blue colour</i>	Preporučuje se za komande, utičnice i nosače lampica sa simbolima <i>It is recommended for controls, sockets and lampholders with symbols</i>	10 10
 0212LDW 0230LDW	<b>0212LDW</b> LED lampica 12-24Vac/dc niske potrošnje - bele boje <i>Low consumption 12-24Vac/dc led lamp - white colour</i>	Preporučuje se za nosače lampica <i>It is recommended for lampholders</i>	10 10
 0212LDR 0230LDR	<b>0212LDR</b> LED lampica 12-24Vac/dc niske potrošnje - crvene boje <i>Low consumption 12-24Vac/dc led lamp - red colour</i>	Preporučuje se za nosače lampica <i>It is recommended for red lampholders</i>	10 10
 0212LDR 0230LDR	<b>0224</b> Inkandescentna lampica 12/24V~ dugog veka trajanja - bele boje <i>Long life incandescent lamp 12/24Vac - white colour</i>		10 10
 0212LDB 0230LDB	<b>0230LDB</b> LED lampica 230V~ niske potrošnje - plave boje <i>Low consumption 230V~ led lamp - blue colour</i>	Preporučuje se za komande, utičnice i nosače lampica <i>It is recommended for controls, sockets and lampholders with symbols</i>	10 10
 0212LDB 0230LDB	<b>0230LDW</b> LED lampica 230V~ niske potrošnje - bele boje <i>Low consumption 230V~ led lamp - white colour</i>	Preporučuje se za nosače lampica <i>It is recommended for lampholders</i>	10 10
 0212LDB 0230LDB	<b>0230LDR</b> LED lampica 230V~ niske potrošnje - crvene boje <i>Low consumption 230V~ led lamp - red colour</i>	Preporučuje se za nosače lampica <i>It is recommended for red lampholders</i>	10 10

### Primer upotrebe signalne lampice

### Signalling lamps application example

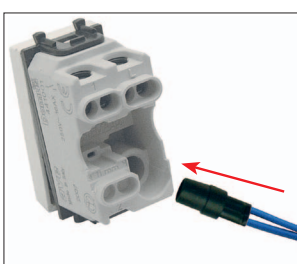

#### Šuko utičnice Schuko Sockets

Predlaže se upotreba LED lampice plave boje (0230LDB)  
*It is recommended the use of blue color led lamp (code 0230LDB)*

#### Comandi Controls

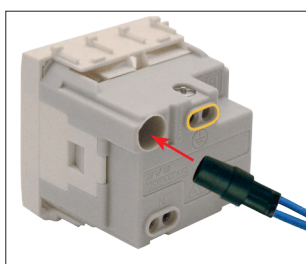

#### Optical Signals

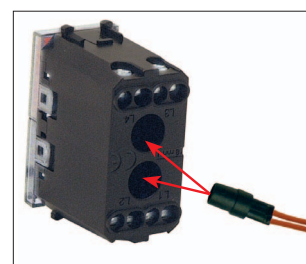

Min. pakovanje kom.  
Min. Packaging pcs

Stand. pakovanje kom.  
Std. Packaging pcs











# Serija DOMUS Touch

DOMUS Touch series



Dimer za regulaciju inteziteta svetla  
Dimmer for lighting controls

126

Domus	Opis	Description	Info	€
 441018	<input type="checkbox"/> 441018	Dimer za svetlo 230V~ (127 V~) 50-60Hz za rezistivna opterećenja (inkandescentne i halogene svetiljke) 60÷800W (30÷500W) i za induktivne (feromagnetni i elektronski transformatori) 40÷300VA - regulacija pomoću rotacionog potenciometra - LED indikator za identifikaciju u mraku - nema EMC filter - 1 modul <i>Dimmer 230V~ (127 V~) 50-60Hz for resistive loads (incandescent and halogen lamps) 60÷800W (30÷500W) and inductive (ferromagnetic and electronic transformers) 40÷300VA - regulation with rotary potentiometer - led for identification in the dark - EMC filter not included - 1 module</i>		1 6
 441048	<input type="checkbox"/> 441048	Dimer za svetlo 230V~ (127 V~) 50-60Hz za rezistivna opterećenja (inkandescentne i halogene svetiljke) 100÷500W (60÷300W) - regulacija pomoću rotacionog potenciometra - LED indikator za identifikaciju u mraku - 1 modul <i>Dimmer 230V~ (127 V~) 50-60Hz for resistive loads (incandescent and halogen lamps) 100÷500W (60÷300W) - regulation with rotary potentiometer - led for identification in the dark - 1 module</i>		1 6
 441048D	<input type="checkbox"/> 441048D	Dimer za svetlo 230V~ 50-60Hz za rezistivna opterećenja (inkandescentne i halogene svetiljke) 40÷300W - upravljanje pomoću ugrađenog naizmjeničnog prekidača i pomoću rotacionog potenciometra - LED indikator za identifikaciju u mraku - smanjena dubina - kontakti sa bočne strane - 1 modul <i>Dimmer 230V~ 50-60Hz for resistive loads (incandescent and halogen lamps) 40÷300W - control with incorporated two-way switch and regulation with rotary potentiometer - led for identification in the dark - reduced depth - side terminal screws - 1 module</i>		1 6
 441048U	<input type="checkbox"/> 441048U	Dimer za svetlo 230V~ 50-60Hz za rezistivna opterećenja 60÷500W (inkandescentne i halogene svetiljke) i za induktivna opterećenja 60÷500VA (feromagnetne transformatore za halogene svetiljke niskog napona) - upravljanje i regulacija pomoću ugrađenog tastera ili sa više udaljenih lokacija preko NO tastera - LED indikator za identifikaciju u mraku - 1 modul <i>Dimmer 230V~ 50-60Hz for resistive loads 60÷500W (incandescent and halogen lamps) and inductive loads 60÷500VA (ferromagnetic transformers for low voltage halogen lamps) controls and regulation with built-in push-button or from more points with normal NO buttons - led for identification in the dark - 1 module</i>		1 6
 441048L	<input type="checkbox"/> 441048L	Dimer za svetlo 230V~ 50-60Hz za kapacitivne elektronske transformatore 40-250VA - upravljanje i regulacija pomoću ugrađenog tastera ili sa više udaljenih lokacija preko standardnih NO tastera - LED indikator za identifikaciju u mraku - 1 modul <i>Dimmer 230V~ 50-60Hz for electronic transformers with 40-250VA capacitive functioning control and regulation with push-button built-in or with normal NO push buttons from more points - led for identification in the dark - 1 module</i>		1 6
 441048AE	<input type="checkbox"/> 441048AE	Dimer za elektronska napajanja sa ulazom 1÷10V (balasti, fluorescentne svetiljke) - izlaz 4A/250V~ - 1 modul <i>Dimmer for electronic power units input 1÷10V - contact 4A/250V~ - 1 module</i>	<b>Novo</b>	1 6

**Napomena:** 441018 se može koristiti samo u zemljama koje nisu članice EU  
**Note:** 441018 must be used only in non-EU Countries

## Dimeri za regulaciju brzine ventilatora fan-coil-a Dimmer for ceiling fan

	Opis	Description	Info	€
 441048AA	<input type="checkbox"/> 441048AA	Dimer za ventilator sa 3 brzine (+isključivanje) 55÷80VA 230V~ 50-60Hz-komanda preko ugrađenog tastera ili sa više udaljenih lokacija pomoću standardnih NO tastera - tehnologija koja garantuje apsolutno "nečujni" rad - LED indikator za identifikaciju u mraku - 1 modul <i>3-speed push button dimmer (+ switch off) 55÷80VA 230V~ 50-60Hz- control with built-in push-button or from more points with normal NO buttons - technology guaranteeing absolute "silence" - led for identification in the dark - 1 module</i>		1 6



Za raspoloživost kontaktirajte  
Ave distributere  
For availability please contact  
sales dept.



Dostupni dok se ne  
rasprodaju zalihe  
Available until stock out



Proizvod za pravougaone  
kutije britanskog standarda  
Product for British standard  
rectangular box



Proizvod za  
izvoz  
For Export  
only

Domus	Opis	Description	Info	€
 <b>441023GSR</b>	<b>□ 441023GSR</b> Elektronski programabilni tajmer - programiranje na dnevnom/nedeljnom/godišnjem nivou - 1 kanal - prenosiv - 1 naizmjenični relejni izlaz 8A (2A induktivno) 230V~ - napajanje 120/230V~ 50-60Hz - 2 modula Electronic programmable time switch 24 hours / 7 days / <b>1 year</b> 1 channel - removable - 1 output through relay by means of a change-over contact 8A (2A Inductive) 230V~ - power supply 120/230V~ 50-60Hz - 2 modules		1	1



Sistema 45

Primer primene *Application example*



**Navodnjavanje bašte**

*Garden Irrigation*



**Osvetljenje u bašti**

*Garden lights*



**Svetleće reklame**

*Illuminated signs*

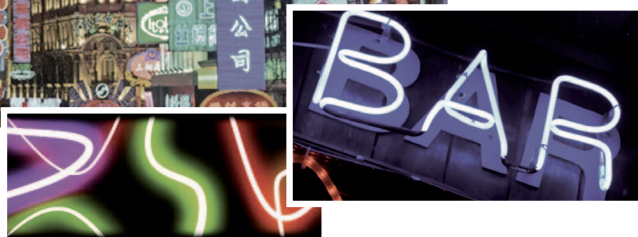

**Farme i staklenici**

*Farms and greenhouses*





# Serija DOMUS Touch

DOMUS Touch series



## Rotacioni selektor brzine za fan-coil Rotary switch for fan-coil

128

Domus	Opis	Description	Info	€
-------	------	-------------	------	---



441055

### □ 441055

Rotacioni selektor brzine 1P 6A (3A induktivni) 250V~ - 4 pozicije za promenu brzine fan-coil-a (ventil-konvektori) - 2 modula

1P 6A (3A inductive) 250V rotary switch 4 positions for fan coil (convectors) - 2 modules

1 1

## Termostati Thermostats

Domus	Opis	Description	Info	€
-------	------	-------------	------	---

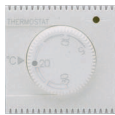

441085

### □ 441085

Elektronski termostat sa rotacionim potencijetrom za kontrolu ambijentalne temperature - izlaz sa naizmničnim kontaktom NO+NC 5A (2A induktivno) 230V~ - opseg regulacije temperature od 5 °C do 30 °C - 50-60 Hz - 2 modula

Electronic thermostat with rotary knob for room temperature control - exit with switching contact NO+NC 5A (2A inductive) - temperature range from 5 °C to 30 °C - 230V~ power supply - 50-60 Hz - 2 modules



1 1



441085SW

### □ 441085SW

Elektronski leto/zima termostat sa displejem i pozadinskim osvetljenjem za kontrolu ambijentalne temperature (grejanje i hladenje) - izlaz sa naizmničnim kontaktima NO+NC 2A 230V~ - opseg regulacije temperature od 0 °C do 35 °C - pozadinski osvetljena kontrolna dugmad - ulaz za aktiviranje sa udaljene lokacije i ulaz za prinudnu redukciju temperature- 50-60 Hz - 2 modula

Electronic winter/summer thermostat with backlighted display for room temperature control (heating and air-conditioning) - exit with switching contacts NO+NC 2A 230V~ - temperature range from 0 °C to 35 °C - backlighted controls - input for remote activation and input for forcing at reduced temperature - 230V~ power supply - 50-60 Hz - 2 modules



1 1

## Hronotermostati 120-230V~ Chronothermostats 120-230V~

Domus	Opis	Description	Info	€
-------	------	-------------	------	---



441CRT

### □ 441CRT

Programabilni elektornski termostat sa displejem i pozadinskim osvetljenjem za kontrolu ambijentalne temperature (grejanje i hladenje) - programiranje na dnevnom/nedeljnom nivou - prenosni - izlaz sa naizmničnim kontaktima NO+NC 3A 230V~ - opseg regulacije temperature od 0 °C do 35 °C - programiranje bazirano na tri temperature (0 °C ÷ 35 °C) korekcija izmerene temperature preko offset funkcije +/-5 °C - programiranje u koracima od 30 minuta - antifriz funkcija - pozadinski osvetljena kontrolna dugmad - ulaz za kontrolu sa udaljene lokacije - višezječni meni - automatsko prebacivanje na zimsko/letnje računanje vremena- napajanje 12 0~/230V~ 50-60 Hz - 2 modula

Electronic winter/summer thermostat with backlighted display for room temperature control (heating and air-conditioning) - daily/weekly programming - **removable** - exit with switching contacts NO+NC 3A 230V~ - programmable based on three temperature levels (0 °C ÷ 35 °C) - adjustment of temperature measured with offset +/-5 °C - setting programs three temperatures (0 °C ÷ 35 °C) - programming with of 30 minutes steps - pump anti-seizing function - backlighted controls - input for remote control - menu with multilingual text guide - automatic switch to daylight saving/solar time - 120~/230V~ power supply - 50-60 Hz - 2 modules



1 1



Za raspoloživost kontaktirajte Ave distributere  
For availability please contact sales dept.



Dostupni dok se ne rasprodaju zalihe  
Available until stock out



Proizvod za pravougaone kutije britanskog standarda  
Product for British standard rectangular box



Proizvod za izvoz  
For Export only

**MAKSIMALNE PERFORMANSE u cilju UŠTEDE ENERGIJE:**

\* Minimalna diferencijalna temperatura: detektovanje minimalnih varijacija u temperaturi radi izbjegavanja velikih oscilacija u sobnoj temperaturi.

\* Minimalni radni offset, što podrazumeva minimalne varijacije u podešenoj temperaturi između režima rada neoptereženog termostata i maksimalno opterećenog termostata.

**MAXIMUM PERFORMANCE for ENERGY SAVING:**

\* Minimum thermic differential: temperature variations are detected in order to avoid extreme room temperature oscillations

\* Minimized on-duty offset, as to say the variation of the adjusted temperature between no load and full load operating conditions.

**Programabilni termostat napajan iz baterije**  
**Chronothermostats with batteries****Domus****Descrizione** *Description***Info**

€

129

**CRONOTC1B****□ CRONOTC1B**

Nadgradni programabilni elektronski termostat sa ekranom na dodir - veliki displej sa pozadinskim osvetljenjem za kontrolu temperature prostorije (grejanje i hladenje)-programiranje na dnevnom/nedeljnom nivou - 5 režima rada: automatski, ručni, holiday, jolly, isključeno - 3 nivoa temperature + antifriz - prikaz registrovane temperature - mogućnost povezivanja temperature sonde u podu - izračunava vreme uključivanja uređaja kako bi se mogla dostići željena temperatura prostorije prema utvrđenom rasporedu - izlaz sa naizmjeničnim kontaktima NO+NC 5A (3A induktivno) 230V~ - opseg regulacije temperature od 2°C do 40°C - napajanje pomoću 2 alkalne baterije tipa AA2x1,5V koje se ne isporučuju uz termostat - višezječni meni - rezerva napajanja (20°C) 1 godina

**New**

1 1



*Electronic wall mounted Touch screen chronothermostat - backlit large display for room temperature control (heating and cooling) - daily/weekly programming - 5 operation modes: automatic, manual, holiday, jolly, off - 3 temperature levels + antifreeze - perceived temperature display - possibility of connection with a floor temperature probe - it calculates the switching on advance needed to reach the desired temperature at the fixed time - exit with switching contacts NO+NC 5A (3A inductive) 230V~ - temperature control range from 2°C to 40°C - powered with two alkaline batteries type AA 2x1,5V not included - menu with multilingual text guide - power supply (20° C) 1 year*

Sistema 45

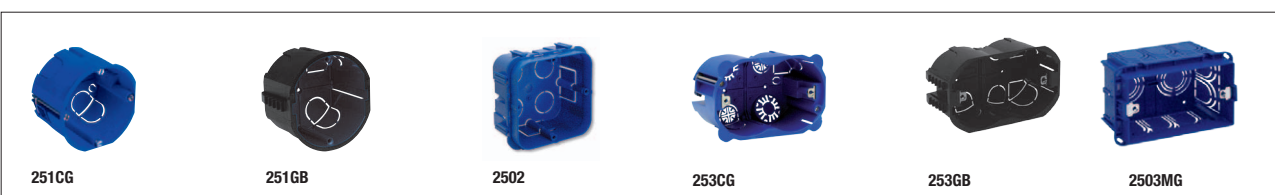
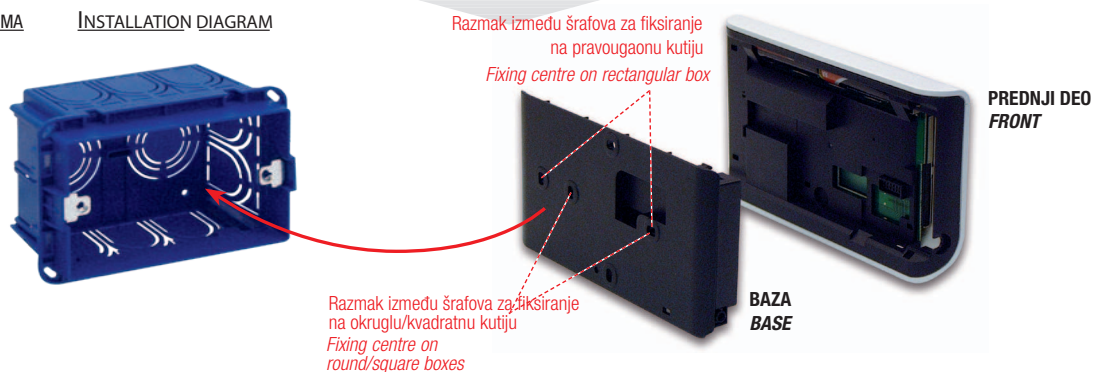
**FRONT VIEW OF CRONOTC1B CHRONOTHERMOSTAT CRONOTC1B****RASPOLOŽIVE KUTIJE****AVAILABLE BOXES****INSTALACIONA ŠEMA****INSTALLATION DIAGRAM**
 Min. pakovanje kom.  
Min. Packaging pcs

 Stand. pakovanje kom.  
Std. Packaging pcs



# Maske

## Front Plates

Boje maski "Vera 44" za okruglu ili kvadratnu kutiju  
"Vera 44" front plates colours for round or square box

Dizajn: B. Dall'Eco

130

### Staklo Glass



**44PV22BL**  
Sjajnobela  
Clear white



**44PV22GO**  
Srebrnosiva mat  
Frosted silver grey



**44PV22NAL**  
Sjajnocrna  
Clear absolute black



**44PV22RPL**  
Sjajnocrvena  
Clear Pompeian red



**44PV22VO**  
Vodnozeleno  
Frosted water green

### Aluminijum Aluminium



**44PA22ALS**  
Brušeni aluminijum  
Natural brushed aluminium

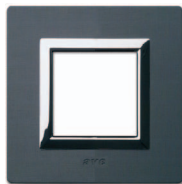

**44PA22ANS**  
Tamni brušeni aluminijum  
Anthracite brushed aluminium



**44PL22RS**  
Izbeljeni hrast  
Whitened oak

### Drvo Wood

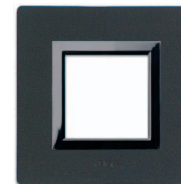

**44PL22WG**  
Wenge  
Wenge



Izmenljivi unutrašnji okviri  
za maske Vera 44 od  
1, 2, 2+2, 2+2+2 modula  
**Interchangeable inner  
frames** for Vera 44 front  
plates  
1, 2, 2+2, 2+2+2 modules

Boje maski "Zama 44" za okruglu ili kvadratnu kutiju  
"Zama 44" front plates colours for round or square box

Dizajn: Luca Merletti

### Metal Metal



**44PK22ALS**  
Brušeni aluminijum  
Natural aluminium



**44PK22AO**  
Srebrna mat  
Matt silver



**44PK22B**  
Sjajnobela RAL 9010  
Ral 9010 white



**44PK22BMC**  
Sjajnobela  
Micalized polished white



**44PK22GF**  
Grafit  
Graphite



**44PK22GSM**  
Tamnosiva metalik  
Metallic dark grey

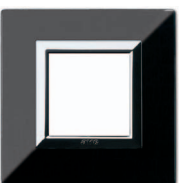

**44PK22NAL**  
Sjajnocrna  
Polished absolute Black



**44PK22NCS**  
Brušeni niki  
Brushed nickel



**44PK22OT**  
Mesing sjajni  
Polished brass



**44PK22PERS**  
Bojiva  
(personalizujuća)  
Treated surface (paintable)



Izmenljivi unutrašnji okviri  
za maske Zama 44 od  
1, 2, 2+2, 2+2+2 modula  
**Interchangeable inner  
frames** for Zama 44 front  
plates  
1, 2, 2+2, 2+2+2 modules



**44P32B**  
 Sjajnobela RAL 9010  
 RAL 9010 white



**44P32SA**  
 Boja peska RAL 1013  
 RAL 1013 sand



**44P32M**  
 Boja mermera  
 Marble



**44P32PS**  
 Boja breskve  
 poluprovodna  
 Opaline peach  
 semi-transparent



**44P32AP**  
 Narandžasta  
 poluprovodna  
 Opaline orange  
 semi-transparent



**44P32GD**  
 Boja žada  
 poluprovodna  
 Opaline jade  
 semi-transparent



**44P32A0**  
 Srebrna mat  
 Matt silver



**44P32GSL**  
 Sjajna tamnosiva  
 Polished dark grey



**44P32CHO**  
 Šampanj mat  
 Matt champagne



**44P32GSM**  
 Tamnosiva metalik  
 Metallic dark grey



**44P32RD**  
 Koren ruže  
 Matt briarwood



**44P320T**  
 Mesing sjajni  
 Polished brass



**44P32BLC**  
 Sjajnobela RAL 9010 - hromirani okvir  
 RAL 9010 white - chrome inner frame



**44P32NAL**  
 Sjajnocrna - hromirani okvir  
 Absolut black - chrome inner frame



**44P32ALS**  
 Brušeni aluminijum - hromirani okvir  
 Natural Aluminium - chrome inner frame



# Maske

## Front Plates

Boje maski "Vera 44" za pravougaone kutije  
"Vera 44" front plates colours for rectangular box

Dizajn: B. Dall'Eco

### Staklo Glass



**44PV3BL**  
Sjajnobela  
Clear white



**44PV3GO**  
Srebrnosiva mat  
Frosted silver grey

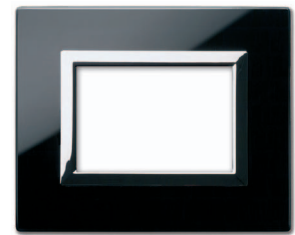

**44PV3NAL**  
Sjajnocrna  
Clear absolute black



**44PV3RPL**  
Sjajnocrvena  
Clear Pompeian red



**44PV3VO**  
Vodenezelena  
Frosted water green



**Izmenljivi unutrašnji okviri**  
za maske 44 od 3, 4, 7,  
3+3, 6+6 modula  
**Interchangeable inner frames**  
for Vera 44 front plates 3, 4, 7,  
3+3, 6+6 modules

### Aluminijum Aluminium

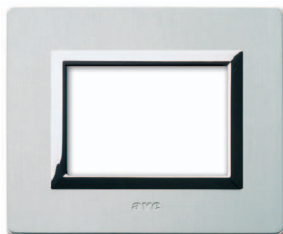

**44PA3ALS**  
Brušeni aluminijum  
Natural brushed aluminium



**44PA3ANS**  
Tamni brušeni aluminijum  
Anthracite brushed aluminium

Horizontalna i vertikalna montaža  
maski 3, 4, 7, 3+3 modula  
Horizontal and Vertical front plates  
Installation 3, 4, 7, 3+3 modules

Na primer 2503MG + BLAS35  
In the example 2503MG + BLAS35

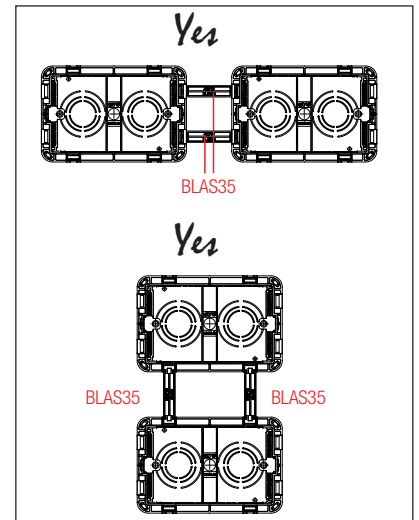

Vidi i šemu koja je data za maske  
"Personal 44"  
See also the scheme in "Personal 44" front plates

### Drvo Wood



**44PL3RS**  
Izbeljeni hrast  
Whitened oak



**44PL3WG**  
Wenge  
Wenge

Boje maski "Zama 44" za pravougaonu kutiju  
 "Zama 44" front plates colours for rectangular box

Dizajn: Luca Merletti

Metal Metal

133



**44P93ALS**  
 Brušeni aluminijum  
*Natural aluminium*



**44P93AO**  
 Srebrna mat  
*Matt silver*

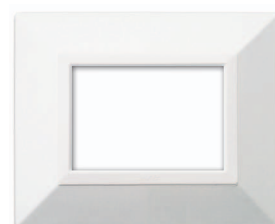

**44P93B**  
 Sjajnobela RAL 9010  
*RAL 9010 white*



**44P93BMC**  
 Sjajnobela  
*Micalized polished white*



**44P93GF**  
 Grafit  
*Graphite*



**44P93GSM**  
 Tamnosiva metalik  
*Metallic dark grey*



**44P93NAL**  
 Sjajnocrna  
*Polished absolute black*



**44P93NCS**  
 Brušeni niki  
*Brushed nickel*



**44P930T**  
 Mesing sjajni  
*Polished brass*



**Izmenljivi unutrašnji okviri**  
 za maske Zama 44 od 3, 4, 7,  
 3+3, 6+6 modula  
**Interchangeable inner frames**  
 for Zama 44 front plates Zama 44  
 da 3, 4, 7, 3+3, 6+6 modules

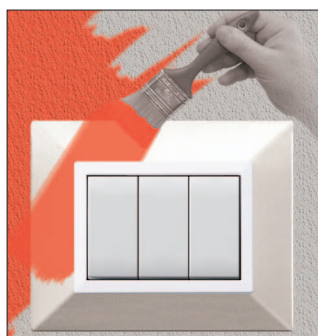

**44P93PERS**  
 Bojiva (personalizujuća)  
*Treated surface (paintable)*





# Maske

## Front Plates

Boje maski "Personal 44" za pravougaone kutije  
 "Personal 44" front plates colours for rectangular box

Dizajn: Luca Merletti

Plastika Plastic



**44P03ALS**  
 Brušeni aluminijum  
 Natural aluminium



**44P03B**  
 Sjajnobela RAL 9010  
 RAL 9010 polished white



**44P03GRL**  
 Sjajna tamnosiva  
 Polished dark grey



**44P03AB**  
 Narandžasta sjajna  
 Bright orange



**44P03BEL**  
 Bež sjajna  
 Polished beige



**44P03CE**  
 Svetloplava  
 Light blue



**44P03AZB**  
 Azurno plava  
 Bright light blue

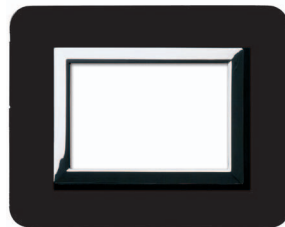

**44P03NAL**  
 Sjajnocrna  
 Polished absolute black



**44P03RPL**  
 Sjajnocrvena  
 Polished Pompeian red

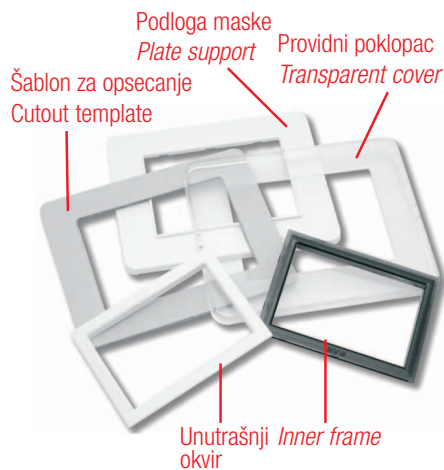

**44P03TR**  
 Providna personalizujuća maska (rastavljena)  
 Transparent customizable front plates (to assemble)



**Izmenljivi unutrašnji okvir**  
 za maske Personal 44  
 od 3, 4, 7, 3+3 modula  
**Interchangeable inner frames**  
 for Personal 44 front plates  
 3, 4, 7,  
 3+3 modules

**Horizontalna i vertikalna montaža maski**  
 Horizontal and Vertical front plates Installation

Na primer 2503MG + BLAS25  
 In the example 2503MG + BLAS25

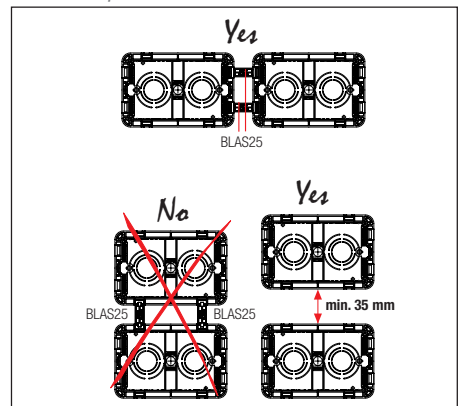

Vidi i šemu koja je data za maske "Vera 44"  
 See also the scheme in "Vera 44" front plates



**44PY03B**  
 Sjajnobela RAL 9010  
*RAL 9010 white*



**44PY03SA**  
 Boja peska RAL 1013  
*RAL 1013 sand*



**44PY03M**  
 Boja mermere  
*Marble*



**44PY03PS**  
 Boja breskve - poluprovodna  
*Opaline peach - semi-transparent*



**44PY03AP**  
 Narandžasta - poluprovodna  
*Opaline orange - semi-transparent*



**44PY03GD**  
 Boja žada - poluprovodna  
*Opaline jade - semi-transparent*



**44PY03AO**  
 Srebrna mat  
*Matt silver*



**44PY03GSL**  
 Sjajna tamnosiva  
*Polished dark grey*



**44PY03CHO**  
 Šampanj mat  
*Matt champagne*



**44PY03GSM**  
 Tamnosiva metalik  
*Metallic dark grey*



**44PY03RD**  
 Koren ruže  
*Matt briarwood*



**44PY030T**  
 Mesing sjajni  
*Polished brass*



**44PY03BLC**  
 Sjajnobela RAL 9010 - hromirani okvir  
*RAL 9010 white - chrome inner frame*



**44PY03NAL**  
 Sjajnocrna - hromirani okvir  
*Absolute black - chrome inner frame*



**44PY03ALS**  
 Brušeni aluminijum - hromirani okvir  
*Natural aluminium - chrome inner frame*



Sistema 45



# Maske

## Front Plates



Maske "Vera 44" za okruglu ili kvadratnu kutiju  
"Vera 44" front plates for round or square box

136

1 MODUL	1 MODULE	Kod Code	Boja Colour	Unutrašnji okvir Inner frame	Info	€
---------	----------	----------	-------------	------------------------------	------	---



### Staklo Glass

44PV21BL	Sjajnobela Clear white	Sjajnobela Ral 9010 Ral 9010 white	1	1
44PV21GO	Srebrnosiva mat Frosted silver grey	Sjajna tamnosiva Polished dark grey	1	1
44PV21NAL	Sjajnocrna Clear absolute black	Hrom Chrome	1	1
44PV21RPL	Sjajno crvena Clear Pompeian red	Sjajna tamnosiva Polished dark grey	1	1
44PV21VO	Vodenezelena Frosted water green	Sjajnobela Ral 9010 Ral 9010 white	1	1

### Aluminijum Aluminium

44PA21ALS	Brušeni aluminijum Natural brushed aluminium	Hrom Chrome	1	1
44PA21ANS	Tamni brušeni aluminijum Anthracite brushed aluminium	Hrom Chrome	1	1

### Drvo Wood

44PL21RS	Izbeljeni hrast Whitened oak	Hrom Chrome	1	1
44PL21WG	Wenge Wenge	Sjajna tamnosiva Polished dark grey	1	1

Koristi se sa armaturom  
To be used with

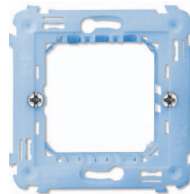

44A02  
44A02SG  
44A02VT

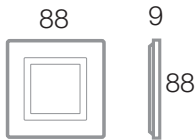

Staklo  
Glass

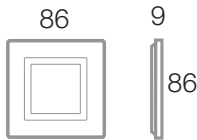

Aluminijum i drvo  
Aluminium and Wood

### Izmenljivi unutrašnji okviri Spare inner frames

Kod Code	Boja Colour	Info	€
----------	-------------	------	---



44CRV21B	Sjajnobela Ral 9010 Ral 9010 white	2	50
44CRV21N	Sjajna tamnosiva Polished dark grey	2	50
44CRV21CR	Hrom Chrome	2	50

### Spoljašnji okvir Finishing ring

Kod Code	Boja Colour	Info	€
----------	-------------	------	---

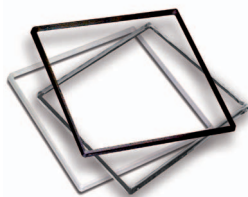

44RNG22B	Sjajnobela Ral 9010 Ral 9010 white	2	50
44RNG22N	Sjajna tamnosiva Polished dark grey	2	50



Za raspoloživost kontaktirajte  
Ave distributere  
For availability please contact  
sales dept.



Dostupni dok se ne  
rasprodaju zalihe  
Available until stock out



Proizvod za pravougaone  
kutije britanskog standarda  
Product for British standard  
rectangular box



Proizvod za  
izvoz  
For Export  
only

## Maske "Vera 44" za okruglu ili kvadratnu kutiju "Vera 44" front plates for round or square box

137



### Vetro Glass

Kod Code	Boja Colour	Unutrašnji okvir Inner frame	Info	€
44PV22BL	Sjajnobela Clear white	Sjajnobela Ral 9010 Ral 9010 white	1	1
44PV22GO	Srebrnosiva mat Frosted silver grey	Sjajna tamnosiva Polished dark grey	1	1
44PV22NAL	Sjajnocrna Clear absolute black	Hrom Chrome	1	1
44PV22RPL	Sjajno crvena Clear Pompeian red	Sjajna tamnosiva Polished dark grey	1	1
44PV22VO	Vodnozelena Frosted water green	Sjajnobela Ral 9010 Ral 9010 white	1	1

### Aluminijum Aluminium

44PA22ALS	Brušeni aluminijum Natural brushed aluminium	Hrom Chrome	1	1
44PA22ANS	Tamni brušeni aluminijum Anthracite brushed aluminium	Hrom Chrome	1	1

### Drvo Wood

44PL22RS	Izbeljeni hrast Whitened oak	Hrom Chrome	1	1
44PL22WG	Wenge Wenge	Sjajna tamnosiva Polished dark grey	1	1

Koristi se sa armaturom  
To be used with

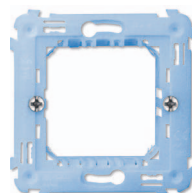

44A02  
44A02SG  
44A02VT

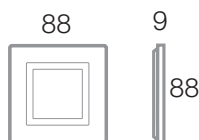

Staklo  
Glass

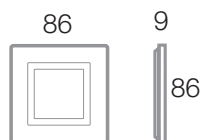

Aluminijum i drvo  
Aluminium and Wood

## Izmenljivi unutrašnji okviri Spare inner frames

Kod Code	Boja Colour	Info	€
44CRV22B	Sjajnobela Ral 9010 Ral 9010 white	2	50
44CRV22N	Sjajna tamnosiva Polished dark grey	2	50
44CRV22CR	Hrom Chrome	2	50

## Spoljašnji okvir Finishing ring

Kod Code	Boja Colour	Info	€
44RNG22B	Sjajnobela Ral 9010 Ral 9010 white	2	50
44RNG22N	Sjajna tamnosiva Polished dark grey	2	50

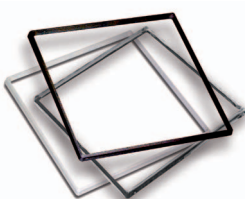



# Maske

## Front Plates



Maske "Vera 44" za okruglu ili kvadratnu kutiju  
"Vera 44" front plates for round or square box

138

4(2+2) MODULA 4(2+2) MODULES **Kod Code** **Boja Colour** **Unutrašnji okvir Inner frame** **Info** **€**



### Staklo Glass

44PV24BL	Sjajnobela Clear white	Sjajnobela Ral 9010 Ral 9010 white	1	1
44PV24GO	Srebrnosiva mat Frosted silver grey	Sjajna tamnosiva Polished dark grey	1	1
44PV24NAL	Sjajnocrna Clear absolute black	Hrom Chrome	1	1
44PV24RPL	Sjajno crvena Clear Pompeian red	Sjajna tamnosiva Polished dark grey	1	1
44PV24VO	Vodenezelena Frosted water green	Sjajnobela Ral 9010 Ral 9010 white	1	1

### Aluminijum Aluminium

44PA24ALS	Brušeni aluminijum Natural brushed aluminium	Hrom Chrome	1	1
44PA24ANS	Tamni brušeni aluminijum Anthracite brushed aluminium	Hrom Chrome	1	1

### Drvo Wood

44PL24RS	Izbeljeni hrast Whitened oak	Hrom Chrome	1	1
44PL24WG	Wenge Wenge	Sjajna tamnosiva Polished dark grey	1	1

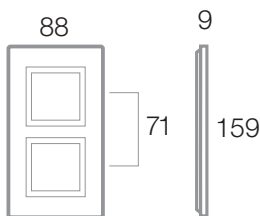

Staklo  
Glass

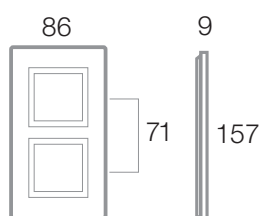

Aluminijum i drvo  
Aluminium and Wood

Koristi se sa armaturom  
To be used with

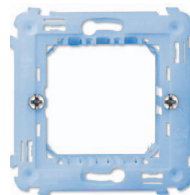

n° 2 44A02  
n° 2 44A02SG  
n° 2 44A02VT

### Izmenljivi unutrašnji okviri Spare inner frames

**Kod Code** **Boja Colour** **Info** **€**



44CRV22B	Sjajnobela Ral 9010 Ral 9010 white	2	50
44CRV22N	Sjajna tamnosiva Polished dark grey	2	50
44CRV22CR	Hrom Chrome	2	50



Za raspoloživost kontaktirajte  
Ave distributere  
For availability please contact  
sales dept.



Dostupni dok se ne  
rasprodaju zalihe  
Available until stock out



Proizvod za pravougaone  
kutije britanskog standarda  
Product for British standard  
rectangular box



Proizvod za  
izvoz  
For Export  
only

## Maske "Vera 44" za okrugle ili kvadratne kutije "Vera 44" front plates for round or square box

6(2+2+2) MODULA 6(2+2+2) MODULES **Kod Code** **Boja Colour** **Unutrašnji okvir Inner frame** **Info** €

139



### Staklo Glass

44PV26BL	Sjajnobela <i>Clear white</i>	Sjajnobela Ral 9010 <i>Ral 9010 white</i>	1	1
44PV26G0	Srebrnosiva mat <i>Frosted silver grey</i>	Sjajna tamnosiva <i>Polished dark grey</i>	1	1
44PV26NAL	Sjajnocrna <i>Clear absolute black</i>	Hrom <i>Chrome</i>	1	1
44PV26RPL	Sjajno crvena <i>Clear Pompeian red</i>	Sjajna tamnosiva <i>Polished dark grey</i>	1	1
44PV26VO	Vodnozeleno <i>Frosted water green</i>	Sjajnobela Ral 9010 <i>Ral 9010 white</i>	1	1

### Aluminijum Aluminium

44PA26ALS	Brušeni aluminijum <i>Natural brushed aluminium</i>	Hrom <i>Chrome</i>	1	1
44PA26ANS	Tamni brušeni aluminijum <i>Anthracite brushed aluminium</i>	Hrom <i>Chrome</i>	1	1

### Drvo Wood

44PL26RS	Izbeljeni hrast <i>Whitened oak</i>	Hrom <i>Chrome</i>	1	1
44PL26WG	Wenge <i>Wenge</i>	Sjajna tamnosiva <i>Polished dark grey</i>	1	1

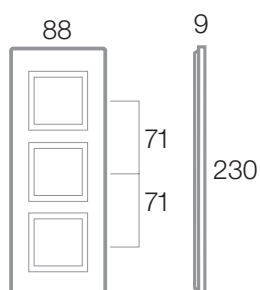

Staklo  
Glass

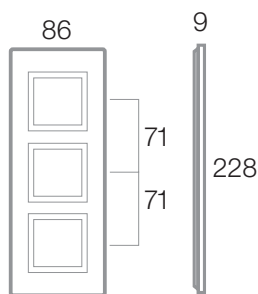

Aluminijum i drvo  
Aluminium and Wood

Koristi se sa armaturom  
To be used with

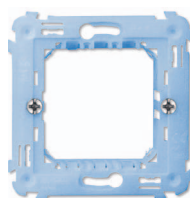

n° 3 44A02  
n° 3 44A02SG  
n° 3 44A02VT

## Izmenljivi unutrašnji okviri Spare inner frames

**Kod Code** **Boja Colour** **Info** €



44CRV22B	Sjajnobela Ral 9010 <i>Ral 9010 white</i>	2	50
44CRV22N	Sjajna tamnosiva <i>Polished dark grey</i>	2	50
44CRV22CR	Hrom <i>Chrome</i>	2	50



# Maske

## Front Plates



### Maske "Vera 44" za okruglu ili kvadratnu kutiju

#### "Vera 44" front plates for round or square box

140

8(2+2+2+2) MODULA 8(2+2+2+2) MODULES

Kod Code

Boja Colour

Unutrašnji okvir Inner frame

Info

€



#### Staklo Glass

44PV28BL	Sjajnobela Clear white	Sjajnobela Ral 9010 Ral 9010 white	1	1
44PV28GO	Srebrnosiva mat Frosted silver grey	Sjajna tamnosiva Polished dark grey	1	1
44PV28NAL	Sjajnocrna Clear absolute black	Hrom Chrome	1	1
44PV28RPL	Sjajno crvena Clear Pompeian red	Sjajna tamnosiva Polished dark grey	1	1
44PV28VO	Vodnozeleno Frosted water green	Sjajnobela Ral 9010 Ral 9010 white	1	1

#### Aluminijum Aluminium

44PA28ALS	Brušeni aluminijum Natural brushed aluminium	Hrom Chrome	1	1
44PA28ANS	Tamni brušeni aluminijum Anthracite brushed aluminium	Hrom Chrome	1	1

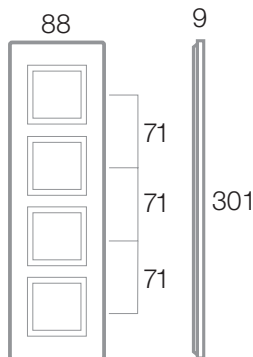

Staklo  
Glass

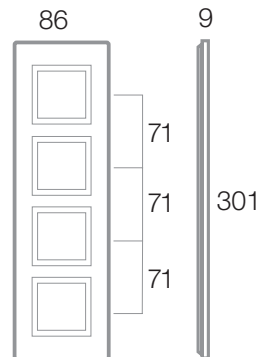

Aluminijum i drvo  
Aluminium and Wood

Koristi se sa armaturom  
To be used with

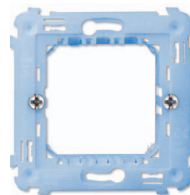

n° 4 44A02  
n° 4 44A02SG  
n° 4 44A02VT

#### Izmenljivi unutrašnji okviri Spare inner frames



Kod Code

Boja Colour

Info

€

44CRV22B	Sjajnobela Ral 9010 Ral 9010 white	2	50
44CRV22N	Sjajna tamnosiva Polished dark grey	2	50
44CRV22CR	Hrom Chrome	2	50



Za raspoloživost kontaktirajte  
Ave distributere  
For availability please contact  
sales dept.



Dostupni dok se ne  
rasprodaju zalihe  
Available until stock out



Proizvod za pravougaone  
kutije britanskog standarda  
Product for British standard  
rectangular box



Proizvod za  
izvoz  
For Export  
only

## Maske "Vera 44" za pravougaonu kutiju "Vera 44" front plates for rectangular box

3 MODULA 3 MODULES    Kod Code    Boja Colour    Unutrašnji okvir Inner frame    Info    €

141



### Staklo Glass

44PV3BL	Sjajnobela Clear white	Sjajnobela Ral 9010 Ral 9010 white	1	1
44PV3GO	Srebrnosiva mat Frosted silver grey	Sjajna tamnosiva Polished dark grey	1	1
44PV3NAL	Sjajnocrna Clear absolute black	Hrom Chrome	1	1
44PV3RPL	Sjajno crvena Clear Pompeian red	Sjajna tamnosiva Polished dark grey	1	1
44PV3VO	Vodnozeleno Frosted water green	Sjajnobela Ral 9010 Ral 9010 white	1	1

### Aluminijum Aluminium

44PA3ALS	Brušeni aluminijum Natural brushed aluminium	Hrom Chrome	1	1
44PA3ANS	Tamni brušeni aluminijum Anthracite brushed aluminium	Hrom Chrome	1	1

### Drvo Wood

44PL3RS	Izbeljeni hrast Whitened oak	Hrom Chrome	1	1
44PL3WG	Wenge Wenge	Sjajna tamnosiva Polished dark grey	1	1

Koristi se sa armaturom  
To be used with

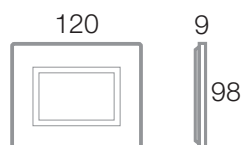

Staklo  
Glass



Aluminijum i drvo  
Aluminium and Wood



44A03

### Izmenljivi unutrašnji okviri Spare inner frames

Kod Code	Boja Colour	Info	€
44CRV3B	Sjajnobela Ral 9010 Ral 9010 white	2	50
44CRV3N	Sjajna tamnosiva Polished dark grey	2	50
44CRV3CR	Hrom Chrome	2	50



### Spoljašnji okvir Finishing ring

Kod Code	Boja Colour	Info	€
44RNG3B	Sjajnobela Ral 9010 Ral 9010 white	2	50
44RNG3N	Sjajna tamnosiva Polished dark grey	2	50







# Maske

## Front Plates



Maske "Vera 44" za pravougaone kutije  
"Vera 44" front plates for rectangular box

142

4 MODULA 4 MODULES



Kod Code	Boja Colour	Unutrašnji okvir Inner frame	Info	€
<b>Vetro Glass</b>				
44PV4BL	Sjajnobela Clear white	Sjajnobela Ral 9010 Ral 9010 white	1	1
44PV4GO	Srebrnosiva mat Frosted silver grey	Sjajna tamnosiva Polished dark grey	1	1
44PV4NAL	Sjajnocrna Clear absolute black	Hrom Chrome	1	1
44PV4RPL	Sjajno crvena Clear Pompeian red	Sjajna tamnosiva Polished dark grey	1	1
44PV4VO	Vodenezelena Frosted water green	Sjajnobela Ral 9010 Ral 9010 white	1	1

### Aluminijum Aluminium

44PA4ALS	Brušeni aluminijum Natural brushed aluminium	Hrom Chrome	1	1
44PA4ANS	Tamni brušeni aluminijum Anthracite brushed aluminium	Hrom Chrome	1	1

### Drvo Wood

44PL4RS	Izbeljeni hrast Whitened oak	Hrom Chrome	1	1
44PL4WG	Wenge Wenge	Sjajna tamnosiva Polished dark grey	1	1

Koristi se sa armaturom  
To be used with



Staklo  
Glass



Aluminijum i drvo  
Aluminium and Wood

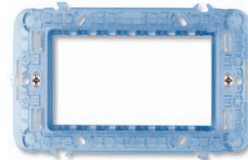

44A04

### Izmenljivi unutrašnji okviri Spare inner frames

Kod Code	Boja Colour	Info	€
44CRV4B	Sjajnobela Ral 9010 Ral 9010 white	2	50
44CRV4N	Sjajna tamnosiva Polished dark grey	2	50
44CRV4CR	Hrom Chrome	2	50

### Spoljašnji okvir Finishing ring

Kod Code	Boja Colour	Info	€
44RNG4B	Sjajnobela Ral 9010 Ral 9010 white	2	50
44RNG4N	Sjajna tamnosiva Polished dark grey	2	50



Za raspoloživost kontaktirajte  
Ave distributere  
For availability please contact  
sales dept.



Dostupni dok se ne  
rasprodaju zalihe  
Available until stock out



Proizvod za pravougaone  
kutije britanskog standarda  
Product for British standard  
rectangular box



Proizvod za izvoz  
For Export  
only

## Maske "Vera 44" za pravougaonu kutiju "Vera 44" front plates for rectangular box

7 MODULA 7 MODULES	Kod Code	Boja Colour	Unutrašnji okvir Inner frame	Info	€
--------------------	----------	-------------	------------------------------	------	---

143



### Staklo Glass

44PV7BL	Sjajnobela Clear white	Sjajnobela Ral 9010 Ral 9010 white	1	1
44PV7GO	Srebrnosiva mat Frosted silver grey	Sjajna tamnosiva Polished dark grey	1	1
44PV7NAL	Sjajnocrna Clear absolute black	Hrom Chrome	1	1
44PV7RPL	Sjajno crvena Clear Pompeian red	Sjajna tamnosiva Polished dark grey	1	1
44PV7VO	Vodnozeleno Frosted water green	Sjajnobela Ral 9010 Ral 9010 white	1	1

### Aluminijum Aluminium

44PA7ALS	Brušeni aluminijum Natural brushed aluminium	Hrom Chrome	1	1
44PA7ANS	Tamni brušeni aluminijum Anthracite brushed aluminium	Hrom Chrome	1	1

### Drvo Wood

44PL7RS	Izbeljeni hrast Whitened oak	Hrom Chrome	1	1
44PL7WG	Wenge Wenge	Sjajna tamnosiva Polished dark grey	1	1

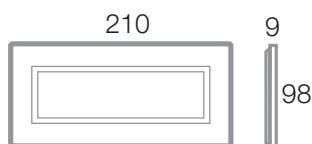

Staklo  
Glass

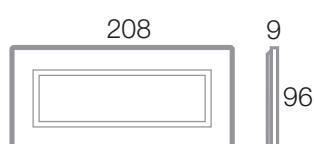

Aluminijum i drvo  
Aluminium and Wood

Koristi se sa armaturom  
To be used with



44A07

### Izmenljivi unutrašnji okvir Spare inner frames

	Kod Code	Colour	Info	€
	44CRV7B	Sjajnobela Ral 9010 Ral 9010 white	2	30
	44CRV7N	Sjajna tamnosiva Polished dark grey	2	30
	44CRV7CR	Hrom Chrome	2	30



# Maske

## Front Plates



### Maske "Vera 44" za kutiju BL02P

"Vera 44" front plates for BL02P box

144

6(3+3) MODULA 6(3+3) MODULES **Kod Code** **Boja Colour** **Unutrašnji okvir Inner frame** **Info** **€**

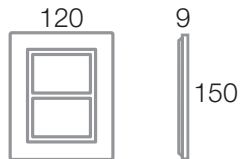

Staklo Glass

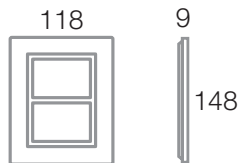
Aluminijum i drvo  
Aluminium and WoodKoristi se sa armaturom  
To be used with  
44A33**Staklo Glass**

44PV33BL	Sjajnobela Clear white	Sjajnobela Ral 9010 Ral 9010 white	1	1
44PV33GO	Srebrnosiva mat Frosted silver grey	Sjajna tamnosiva Polished dark grey	1	1
44PV33NAL	Sjajnocrna Clear absolute black	Hrom Chrome	1	1
44PV33RPL	Sjajno crvena Clear Pompeian red	Sjajna tamnosiva Polished dark grey	1	1
44PV33VO	Vodenezelena Frosted water green	Sjajnobela Ral 9010 Ral 9010 white	1	1

**Aluminijum Aluminium**

44PA33ALS	Brušeni aluminijum Natural brushed aluminium	Hrom Chrome	1	1
44PA33ANS	Tamni brušeni aluminijum Anthracite brushed aluminium	Hrom Chrome	1	1

**Drvo Wood**

44PL33RS	Izbeljeni hrast Whitened oak	Hrom Chrome	1	1
44PL33WG	Wenge Wenge	Sjajna tamnosiva Polished dark grey	1	1

**Izmenljivi unutrašnji okviri Spare inner frames**

**Kod Code** **Boja Colour** **Info** **€**



44CRV33B	Sjajnobela Ral 9010 Ral 9010 white	2	50
44CRV33N	Sjajna tamnosiva Polished dark grey	2	50
44CRV33CR	Hrom Chrome	2	50
44CRV33CR/AP	Hrom - verzija bez prečke, koristi se za zvučnike 441AP01 ili 442AP01 Chrome - version without central cross bar to be used with 441AP01 or 442AP01 speakers	2	50

### Maske "Vera 44" za kutiju BL05P i BL05CG

"Vera 44" front plates for BL05P and BL05CG boxes

12(6+6) MODULA 12(6+6) MODULES **Kod Code** **Boja Colour** **Info** **€**

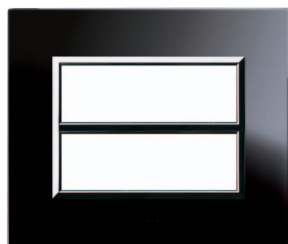
Koristi se sa armaturom  
To be used with  
44A12**Staklo Glass**

44PV12BL	Sjajnobela Clear white	Sjajnobela Ral 9010 Ral 9010 white	1	1
44PV12NAL	Sjajnocrna Clear absolute black	Hrom Chrome	1	1

**Aluminijum Aluminium**

44PA12ALS	Brušeni aluminijum Natural brushed aluminium	Hrom Chrome	1	1
44PA12ANS	Tamni brušeni aluminijum Anthracite brushed aluminium	Hrom Chrome	1	1

Za raspoloživost kontaktirajte  
Ave distributere  
For availability please contact  
sales dept.Dostupni dok se ne  
rasprodaju zalihe  
Available until stock out# Proizvod za pravougaone  
kutije britanskog standarda  
Product for British standard  
rectangular boxProizvod za  
izvoz  
For Export  
only

## Metalne maske "Zama 44" za okruglu ili kvadratnu kutiju "Zama 44" metal front plates for round or square box

1 MODUL	1 MODULE	Kod Code	Boja Colour	Unutrašnji okvir Inner frame	Info	€
	44PK21ALS	Brušeni aluminijum Natural aluminium	Hrom Chrome	1	15	
	44PK21AO	Srebrna mat Matt silver	Sjajna tamnosiva Polished dark grey	1	15	
	44PK21B	Sjajnobela Ral 9010 Ral 9010 white	Sjajnobela 9010 Ral 9010 white	<b>Novo</b>	1	15
	44PK21BMC	Sjajnobela Micalized polished white	Sjajnobela 9010 Ral 9010 white	1	15	
	44PK21GF	Grafit Graphite	Sjajna tamnosiva Polished dark grey	1	15	
	44PK21GSM	Tamnosaiva metalik Metallic dark grey	Hrom Chrome	1	15	
	44PK21NAL	Sjajnocrna Polished Absolute black	Hrom Chrome	1	15	
	44PK21NGS	Brušeni niki Brushed nickel	Sjajna tamnosiva Polished dark grey	1	15	
	44PK21OT	Mesing sjajni Polished brass	Hrom Chrome	1	15	
	44PK21PERS	Bojiva (personalizujuća) Treated surface (paintable)	Sjajnobela 9010 (uključena) Sjajna tamnosiva (uključena) RAL 9010 white (included) Polished dark grey (included)	1	15	

**Napomena:** ✓ 44PK21PERS ima specijalnu podlogu koja omogućava bojenje maske bilo kojom bojom/farbom na vodenoj bazi za zatvorene ili otvorene prostore. Ne smeju se koristiti boje i razredivači na alkoholnoj ili nitro bazi.

✓ Masku obojite pre nego što je postavite na armaturu i pre nego što postavite unutrašnji okvir.

✓ 44PK21PERS is specially treated to be paintable with any common water-based paint or enamel for indoor and outdoor. Do not use alcohol-based nor nitro-based paints or catalysts.

✓ Paint the front plate before hooking the inner frame and before mounting it.

Koristi se sa armaturom  
To be used with

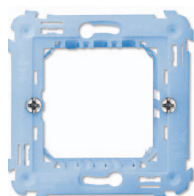
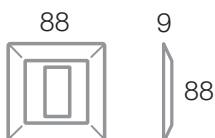

44A02  
44A02SG  
44A02VT

## Izmenljivi unutrašnji okviri Spare inner frames

	Kod Code	Boja Colour	Info	€
	44CRK21B	Sjajnobela Ral 9010 Ral 9010 white	2	50
	44CRK21N	Sjajna tamnosiva Polished dark grey	2	50
	44CRK21CR	Hrom Chrome	2	50



# Maske

## Front Plates



Metalne maske "Zama 44" za okruglu ili kvadratnu kutiju  
"Zama 44" metal front plates for round or square box

146

2 MODULA 2 MODULES



Kod Code	Boja Colour	Unutrašnji okvir Inner frame	Info	€
44PK22ALS	Brušeni aluminijum Natural aluminium	Hrom Chrome		1 15
44PK22AO	Srebrna mat Matt silver	Sjajna tamnosiva Polished dark grey		1 15
44PK22B	Sjajnobela Ral 9010 Ral 9010 white	Sjajnobela Ral 9010 Ral 9010 white	<b>Novo</b>	1 15
44PK22BMC	Sjajnobela Micalized polished white	Sjajnobela Ral 9010 Ral 9010 white		1 15
44PK22GF	Grafit Graphite	Sjajna tamnosiva Polished dark grey		1 15
44PK22GSM	Tamnosiva metalik Metallic dark grey	Hrom Chrome		1 15
44PK22NAL	Sjajnocrna Polished Absolute black	Hrom Chrome		1 15
44PK22NCS	Brušeni niki Brushed nickel	Sjajna tamnosiva Polished dark grey		1 15
44PK22OT	Mesing sjajni Polished brass	Hrom Chrome		1 15
44PK22PERS	Bojiva (personalizujuća) Treated surface (paintable)	Sjajnobela Ral 9010 (uključena) Sjajna tamnosiva (uključena) RAL 9010 white (included) Polished dark grey (included)		1 15

- Napomena:** ✓ 44PK22PERS ima specijalnu podlogu koja omogućava bojenje maske bilo kojom bojom/farbom na vodenoj bazi za zatvorene ili otvorene prostore. Ne smeju se koristiti boje i razređivači na alkoholnoj ili nitro bazi.  
✓ Masku obojite pre nego što je postavite na armaturu i pre nego što postavite unutrašnji okvir.  
✓ 44PK22PERS is specially treated to be paintable with any common water-based paint or enamel for indoor and outdoor. Do not use alcohol-based nor nitro-based paints or catalysts.  
✓ Paint the front plate before hooking the inner frame and before mounting it.

Koristi se sa armaturom  
To be used with

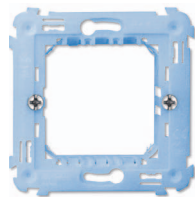
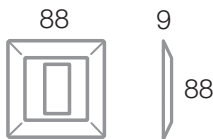

44A02  
44A02SG  
44A02VT

### Izmenljivi unutrašnji okviri Spare inner frames



Kod Code	Boja Colour	Info	€
44CRK22B	Sjajnobela Ral 9010 Ral 9010 white		2 50
44CRK22N	Sjajna tamnosiva Polished dark grey		2 50
44CRK22CR	Hrom Chrome		2 50



Za raspoloživost kontaktirajte  
Ave distributere  
For availability please contact  
sales dept.



Dostupni dok se ne  
rasprodaju zalihe  
Available until stock out



Proizvod za pravougaone  
kutije britanskog standarda  
Product for British standard  
rectangular box



Proizvod za  
izvoz  
For Export  
only

## Metalne maske "Zama 44" za okruglu ili kvadratnu kutiju "Zama 44" metal front plates for round or square box

147



4(2+2) MODULA 4(2+2) MODULES	Kod Code	Boja Colour	Unutrašnji okvir Inner frame	Info	€
	44PK24ALS	Brušeni aluminijum Natural aluminium	Hrom Chrome		1 10
	44PK24AO	Srebrna mat Matt silver	Sjajna tamnosiva Polished dark grey		1 10
	44PK24B	Sjajnobela Ral 9010 Ral 9010 white	Sjajnobela Ral 9010 Ral 9010 white	<b>Novo</b>	1 15
	44PK24BMC	Sjajnobela Micalized polished white	Sjajnobela Ral 9010 Ral 9010 white		1 10
	44PK24GF	Grafit Graphite	Sjajna tamnosiva Polished dark grey		1 10
	44PK24GSM	Tamnosiva metalik Metallic dark grey	Hrom Chrome		1 10
	44PK24NAL	Sjajnocrna Polished Absolute black	Hrom Chrome		1 10
	44PK24NCS	Brušeni nikel Brushed nickel	Sjajna tamnosiva Polished dark grey		1 10
	44PK24OT	Mesing sjajni Polished brass	Hrom Chrome		1 10
	44PK24PERS	Bojiva (personalizujuća) Treated surface (paintable)	Sjajnobela Ral 9010 (uključena) Sjajna tamnosiva (uključena) RAL 9010 white (included) Polished dark grey (included)		1 10

88

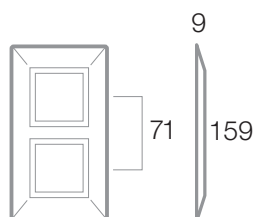

- Napomena:** ✓ 44PK24PERS ima specijalnu podlogu koja omogućava bojenje maske bilo kojom bojom/farbom na vodenoj bazi za zatvorene ili otvorene prostore. Ne smeju se koristiti boje i razredivači na alkoholnoj ili nitro bazi.  
 ✓ Masku obojite pre nego što je postavite na armaturu i pre nego što postavite unutrašnji okvir.  
 ✓ 44PK24PERS is specially treated to be paintable with any common water-based paint or enamel for indoor and outdoor. Do not use alcohol-based nor nitro-based paints or catalysts.  
 ✓ Paint the front plate before hooking the inner frame and before mounting it.

### Način instaliranja Installation solution

Koristi se sa armaturom  
To be used with

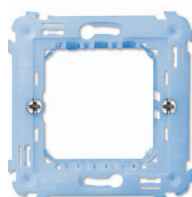

n° 2 44A02  
n° 2 44A02SG  
n° 2 44A02VT



Kutije  
Boxes

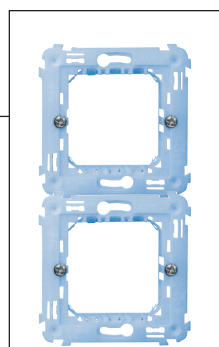

Armature koje se mogu spajati  
Frames that can be coupled



Maska  
Front plate

### Izmenljivi unutrašnji okviri Spare inner frames



Kod Code	Boja Colour	Info	€
44CRK22B	Sjajnobela Ral 9010 Ral 9010 white		2 50
44CRK22N	Sjajna tamnosiva Polished dark grey		2 50
44CRK22CR	Hrom Chrome		2 50

Min. pakovanje kom.  
Min. Packaging pcs

Stand. pakovanje kom.  
Std. Packaging pcs



# Maske

## Front Plates



Metalne maske "Zama 44" za okruglu ili kvadratnu kutiju  
"Zama 44" metal front plates for round or square box

148

6(2+2+2) MODULA 6(2+2+2) MODULES Kod Code Boja Colour Unutrašnji okvir Inner frame Info €



44PK26ALS	Brušeni aluminijum Natural aluminium	Hrom Chrome	1	5
44PK26AO	Srebrna mat Matt silver	Sjajna tamnosiva Polished dark grey	1	5
44PK26B	Sjajnobela Ral 9010 Ral 9010 white	Sjajnobela Ral 9010 Ral 9010 white	<b>Novo</b>	1 15
44PK26BMC	Sjajnobela Micalized polished white	Sjajnobela Ral 9010 Ral 9010 white	1	5
44PK26GF	Grafit Graphite	Sjajna tamnosiva Polished dark grey	1	5
44PK26GSM	Tamnosa metalik Metallic dark grey	Hrom Chrome	1	5
44PK26NAL	Sjajnocrna Polished Absolute black	Hrom Chrome	1	5
44PK26NCS	Brušeni niki Brushed nickel	Sjajna tamnosiva Polished dark grey	1	5
44PK26OT	Mesing sjajni Polished brass	Hrom Chrome	1	5
44PK26PERS	Bojiva (personalizujuća) Treated surface (paintable)	Sjajnobela Ral 9010 (uključena) Sjajna tamnosiva (uključena) RAL 9010 white (included) Polished dark grey (included)	1	5

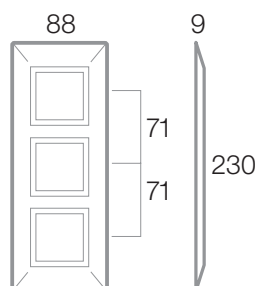

- Napomena:** ✓ 44PK26PERS ima specijalnu podlogu koja omogućava bojenje maske bilo kojom bojom/farbom na vodenoj bazi za zatvorene ili otvorene prostore. Ne smeju se koristiti boje i razređivači na alkoholnoj ili nitro bazi.  
✓ Masku obojite pre nego što je postavite na armaturu i pre nego što postavite unutrašnji okvir.  
✓ 44PK26PERS is specially treated to be paintable with any common water-based paint or enamel for indoor and outdoor. Do not use alcohol-based nor nitro-based paints or catalysts.  
✓ Paint the front plate before hooking the inner frame and before mounting it.

### Način instaliranja Installation solution

Koristi se sa armaturom  
To be used with

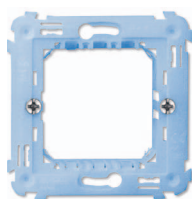

n° 3 44A02  
n° 3 44A02SG  
n° 3 44A02VT

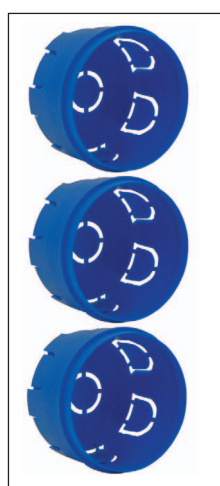

Kutije  
Boxes

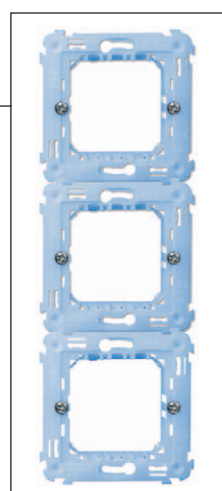

Armature koje se mogu spajati  
Frames that can be coupled



Maska Front plate

### Izmenljivi unutrašnji okviri Spare inner frames

Kod Code	Boja Colour	Info	€
44CRK22B	Sjajnobela Ral 9010 Ral 9010 white	2	50
44CRK22N	Sjajna tamnosiva Polished dark grey	2	50
44CRK22CR	Hrom Chrome	2	50



Za raspoloživost kontaktirajte  
Ave distributere  
For availability please contact  
sales dept.



Dostupni dok se ne  
rasprodaju zalihe  
Available until stock out



Proizvod za pravougaone  
kutije britanskog standarda  
Product for British standard  
rectangular box



Proizvod za  
izvoz  
For Export  
only

## Metalne maske "Zama 44" za pravougaonu kutiju "Zama 44" metal front plates for rectangular box

3 MODULA 3 MODULES	Kod Code	Boja Colour	Unutrašnji okvir Inner frame	Info	€
	44P93ALS	Brušeni aluminijum Natural aluminium	Hrom Chrome		1 12
	44P93AO	Srebrna mat Matt silver	Sjajna tamnosiva Polished dark grey		1 12
	44P93B	Sjajnobela Ral 9010 Ral 9010 white	Sjajnobela Ral 9010 Ral 9010 white	<b>Novo</b>	1 12
	44P93BMC	Sjajnobela Micalized polished white	Sjajnobela Ral 9010 Ral 9010 white		1 12
	44P93GF	Grafit Graphite	Sjajna tamnosiva Polished dark grey		1 12
	44P93GSM	Tamnosiva metalik Metallic dark grey	Hrom Chrome		1 12
	44P93NAL	Sjajnocrna Polished Absolute black	Hrom Chrome		1 12
	44P93NCS	Brušeni nikel Brushed nickel	Sjajna tamnosiva Polished dark grey		1 12
	44P93OT	Mesing sjajni Polished brass	Hrom Chrome		1 12
	44P93PERS	Bojiva (personalizujuća) Treated surface (paintable)	Sjajnobela Ral 9010 (uključena) Sjajna tamnosiva (uključena) RAL 9010 white (included) Polished dark grey (included)		1 12

- Napomena:** ✓ 44P93PERS ima specijalnu podlogu koja omogućava bojenje maske bilo kojom bojom/farbom na vodenoj bazi za zatvorene ili otvorene prostore. Ne smeju se koristiti boje i razređivači na alkoholnoj ili nitro bazi.  
 ✓ Masku obojite pre nego što je postavite na armaturu i pre nego što postavite unutrašnji okvir.  
 ✓ 44P93PERS is specially treated to be paintable with any common water-based paint or enamel for indoor and outdoor. Do not use alcohol-based nor nitro-based paints or catalysts.  
 ✓ Paint the front plate before hooking the inner frame and before mounting it.

Koristi se sa armaturom  
To be used with

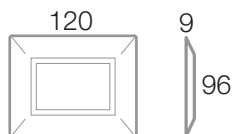

44A03

### Izmenljivi unutrašnji okviri Spare inner frames

	Kod Code	Boja Colour	Info	€
	44CR3B	Sjajnobela Ral 9010 Ral 9010 white		2 50
	44CR3N	Sjajna tamnosiva Polished dark grey		2 50
	44CR3CR	Hrom Chrome		2 50







# Maske

## Front Plates



### Metalne maske "Zama 44" za pravougaonu kutiju "Zama 44" metal front plates for rectangular box

150

4 MODULA 4 MODULES



Kod Code	Boja Colour	Unutrašnji okvir Inner frame	Info	€
44P94ALS	Brušeni aluminijum Natural aluminium	Hrom Chrome		1 10
44P94AO	Srebrna mat Matt silver	Sjajna tamnosiva Polished dark grey		1 10
44P94B	Sjajnobela Ral 9010 Ral 9010 white	Sjajnobela Ral 9010 Ral 9010 white	<b>Novo</b>	1 12
44P94BMC	Sjajnobela Micalized polished white	Sjajnobela Ral 9010 Ral 9010 white		1 10
44P94GF	Grafit Graphite	Sjajna tamnosiva Polished dark grey		1 10
44P94GSM	Tamnosiva metalik Metallic dark grey	Hrom Chrome		1 10
44P94NAL	Sjajnocrna Polished Absolute black	Hrom Chrome		1 10
44P94NCS	Brušeni niki Brushed nickel	Sjajna tamnosiva Polished dark grey		1 10
44P94OT	Mesing sjajni Polished brass	Hrom Chrome		1 10
44P94PERS	Bojiva (personalizujuća) Treated surface (paintable)	Sjajnobela Ral 9010 (uključena) Sjajna tamnosiva (uključena) RAL 9010 white (included) Polished dark grey (included)		1 10

**Napomena:** ✓ 44P94PERS ima specijalnu podlogu koja omogućava bojenje maske bilo kojom bojom/farbom na vodenoj bazi za zatvorene ili otvorene prostore. Ne smeju se koristiti boje i razređivači na alkoholnoj ili nitro bazi.

✓ Masku obojite pre nego što je postavite na armaturu i pre nego što postavite unutrašnji okvir.

✓ 44P94PERS is specially treated to be paintable with any common water-based paint or enamel for indoor and outdoor. Do not use alcohol-based nor nitro-based paints or catalysts.

✓ Paint the front plate before hooking the inner frame and before mounting it.

Koristi se armaturom  
To be used with

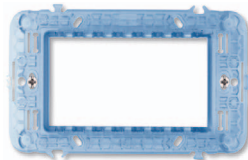
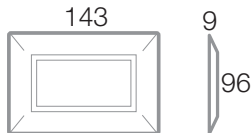

44A04

### Izmenljivi unutrašnji okviri Spare inner frames



Kod Code	Boja Colour	Info	€
44CR4B	Sjajnobela Ral 9010 Ral 9010 white		2 50
44CR4N	Sjajna tamnosiva Polished dark grey		2 50
44CR4CR	Hrom Chrome		2 50



Za raspoloživost kontaktirajte  
Ave distributere  
For availability please contact  
sales dept.



Dostupni dok se ne  
rasprodaju zalihe  
Available until stock out



Proizvod za pravougaone  
kutije britanskog standarda  
Product for British standard  
rectangular box



Proizvod za  
izvoz  
For Export  
only

## Metalne maske "Zama 44" za pravougaonu kutiju "Zama 44" metal front plates for rectangular box

7 MODULA 7 MODULES	Kod Code	Boja Colour	Unutrašnji okvir Inner frame	Info	€
	44P97ALS	Brušeni aluminijum Natural aluminium	Hrom Chrome		1 5
	44P97AO	Srebrna mat Matt silver	Sjajna tamnosiva Polished dark grey		1 5
	44P97B	Sjajnobela Ral 9010 Ral 9010 white	Sjajnobela Ral 9010 Ral 9010 white	<b>Novo</b>	1 12
	44P97BMC	Sjajnobela Micalized polished white	Sjajnobela Ral 9010 Ral 9010 white		1 5
	44P97GF	Grafit Graphite	Sjajna tamnosiva Polished dark grey		1 5
	44P97GSM	Tamnosiva metalik Metallic dark grey	Hrom Chrome		1 5
	44P97NAL	Sjajnocrna Polished Absolute black	Hrom Chrome		1 5
	44P97NCS	Brušeni nikel Brushed nickel	Sjajna tamnosiva Polished dark grey		1 5
	44P97OT	Mesing sjajni Polished brass	Hrom Chrome		1 5
	44P97PERS	Bojiva (personalizujuća) Treated surface (paintable)	Sjajnobela Ral 9010 (uključena) Sjajna tamnosiva (uključena) RAL 9010 white (included) Polished dark grey (included)		1 5

- Napomena:** ✓ 44P97PERS ima specijalnu podlogu koja omogućava bojenje maske bilo kojom bojom/farbom na vodenoj bazi za zatvorene ili otvorene prostore. Ne smeju se koristiti boje i razređivači na alkoholnoj ili nitro bazi.
- ✓ Masku obojite pre nego što je postavite na armaturu i pre nego što postavite unutrašnji okvir.
- ✓ 44P97PERS is specially treated to be paintable with any common water-based paint or enamel for indoor and outdoor. Do not use alcohol-based nor nitro-based paints or catalysts.
- ✓ Paint the front plate before hooking the inner frame and before mounting it.

Koristi se sa armaturom  
To be used with

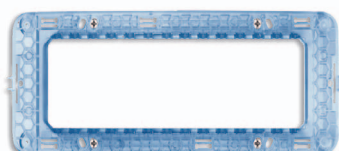
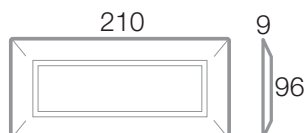

44A07

## Izmenljivi unutrašnji okviri Spare inner frames

	Kod Code	Boja Colour	Info	€
	44CR7B	Sjajnobela Ral 9010 Ral 9010 white		2 30
	44CR7N	Sjajna tamnosiva Polished dark grey		2 30
	44CR7CR	Hrom Chrome		2 30

151



Sistema 45



# Maske

## Front Plates



### Metalne maske "Zama 44" za kutiju BL02P "Zama 44" metal front plates for BL02P box

152

6(3+3) MODULA 6(3+3) MODULES	Kod Code	Boja Colour	Unutrašnji okvir Inner frame	Info	€
	44P933ALS	Brušeni aluminijum <i>Natural aluminium</i>	Hrom <i>Chrome</i>		1 1
	44P933AO	Srebrna mat <i>Matt silver</i>	Sjajna tamnosiva <i>Polished dark grey</i>		1 1
	44P933B	Sjajnobela Ral 9010 <i>RAL 9010 white</i>	Sjajnobela Ral 9010 <i>RAL 9010 white</i>	<b>Novo</b>	1 1
	44P933BMC	Sjajnobela <i>Micalized polished white</i>	Sjajnobela Ral 9010 <i>RAL 9010 white</i>		1 1
	44P933GF	Grafit <i>Graphite</i>	Sjajna tamnosiva <i>Polished dark grey</i>		1 1
	44P933GSM	Tamosiva metalik <i>Metallic dark grey</i>	Hrom <i>Chrome</i>		1 1
	44P933NAL	Sjajnocrna <i>Polished Absolute black</i>	Hrom <i>Chrome</i>		1 1
	44P933NCS	Brušeni niki <i>Brushed nickel</i>	Sjajna tamnosiva <i>Polished dark grey</i>		1 1
	44P933OT	Mesing sjajni <i>Polished brass</i>	Hrom <i>Chrome</i>		1 1
	44P933PERS	Bojiva (personalizujuća) <i>Treated surface (paintable)</i>	Sjajnobela Ral 9010 (uključena) Sjajna tamnosiva (uključena) <i>RAL 9010 white (included)</i> <i>Polished dark grey (included)</i>		1 1

**Napomena:** ✓ 44P933PERS ima specijalnu podlogu koja omogućava bojenje maske bilo kojom bojom/farborom na vodenoj bazi za zatvorene ili otvorene prostore. Ne smeju se koristiti boje i razređivači na alkoholnoj ili nitro bazi.

✓ Masku obojite pre nego što je postavite na armaturu i pre nego što postavite unutrašnji okvir.

✓ 44P933PERS is specially treated to be paintable with any common water-based paint or enamel for indoor and outdoor. Do not use alcohol-based nor nitro-based paints or catalysts.

✓ Paint the front plate before hooking the inner frame and before mounting it.

Koristi se sa armaturom  
To be used with

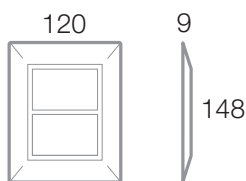

44A33

### Izmenljivi unutrašnji okvir Spare inner frames

	Kod Code	Boja Colour	Info	€
	44CR33B	Sjajnobela Ral 9010 <i>Ral 9010 white</i>		2 50
	44CR33N	Sjajna tamnosiva <i>Polished dark grey</i>		2 50
	44CR33CR	Hrom <i>Chrome</i>		2 50
	44CR33CR/AP	Hrom - verzija bez prečke, koristi se za zvučnike 441AP01 ili 442AP01 <i>Chrome - version without central cross bar to be used with 441AP01 or 442AP01 speakers</i>		2 50



Za raspoloživost kontaktirajte Ave distributere  
For availability please contact sales dept.



Dostupni dok se ne rasprodaju zalihe  
Available until stock out



Proizvod za pravougaone kutije britanskog standarda  
Product for British standard rectangular box



Proizvod za izvoz  
For Export only

## Metalne maske "Zama 44" za kutije BL05P i BL05CG "Zama 44" metal front plates for BL05P and BL05CG boxes

12(6+6) MODULA 12(6+6) MODULES	Kod Code	Boja Colour	Unutrašnji okvir Inner frame	Info	€
	44P912ALS	Brušeni aluminijum <i>Natural aluminium</i>	Hrom <i>Chrome</i>		1 1
	44P912AO	Srebrna mat <i>Matt silver</i>	Sjajna tamnosiva <i>Polished dark grey</i>		1 1
	44P912B	Sjajnobela Ral 9010 <i>RAL 9010 white</i>	Sjajnobela Ral 9010 <i>RAL 9010 white</i>	<b>Novo</b>	1 1
	44P912BMC	Sjajnobela <i>Micalized polished white</i>	Sjajnobela Ral 9010 <i>RAL 9010 white</i>		1 1
	44P912GSM	Tamnosiva metalik <i>Metallic dark grey</i>	Hrom <i>Chrome</i>		1 1
	44P912NAL	Sjajnocrna <i>Polished Absolute black</i>	Hrom <i>Chrome</i>		1 1
	44P912PERS	Bojiva (personalizujuća) <i>Treated surface (paintable)</i>	Sjajnobela Ral 9010 (uključena) Sjajna tamnosiva (uključena) <i>RAL 9010 white (included)</i> <i>Polished dark grey (included)</i>		1 1

- Napomena:** ✓ 44P912PERS ima specijalnu podlogu koja omogućava bojenje maske bilo kojom bojom/farbom na vodenoj bazi za zatvorene ili otvorene prostore. Ne smeju se koristiti boje i razređivači na alkoholnoj ili nitro bazi.  
 ✓ Masku obojite pre nego što je postavite na armaturu i pre nego što postavite unutrašnji okvir.  
 ✓ 44P912PERS is specially treated to be paintable with any common water-based paint or enamel for indoor and outdoor. Do not use alcohol-based nor nitro-based paints or catalysts.  
 ✓ Paint the front plate before hooking the inner frame and before mounting it.

Koristi se sa armaturom  
To be used with

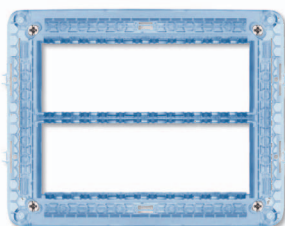
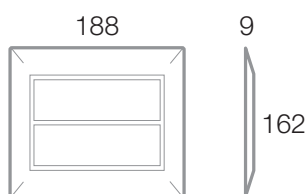

44A12

### Izmenljivi unutrašnji okviri Spare inner frames

	Kod Code	Boja Colour	Info	€
	44CR12B	Sjajnobela Ral 9010 <i>Ral 9010 white</i>		2 14
	44CR12N	Sjajna tamnosiva <i>Polished dark grey</i>		2 14
	44CR12CR	Hrom <i>Chrome</i>		2 14





# Maske

## Front Plates



### Maske "Personal 44" za pravougaonu kutiju

"Personal 44" front plates for rectangular box

154

3 MODULA 3 MODULES



Kod Code	Boja Colour	Unutrašnji okvir Inner frame	Info	€
44P03AB	Narandžasta sjajna Bright orange	Sjajnobela Ral 9010 Ral 9010 white	1	12
44P03ALS	Brušeni aluminijum Natural aluminium	Hrom Chrome	1	12
44P03AZB	Azurnoplava Bright light blue	Sjajnobela Ral 9010 Ral 9010 white	1	12
44P03B	Sjajnobela Ral 9010 Ral 9010 polished white	Sjajnobela Ral 9010 Ral 9010 white	1	12
44P03BEL	Bež sjajna Polished beige	Sjajnobela Ral 9010 Ral 9010 white	1	12
44P03CE	Svetloplava Light blue	Sjajnobela Ral 9010 Ral 9010 white	1	12
44P03GRL	Sjajna tamnosiva Polished dark grey	Sjajnobela Ral 9010 Ral 9010 white	1	12
44P03NAL	Sjajnocrna Absolute black	Hrom Chrome	1	12
44P03RPL	Sjajnocrvena Pompeian red	Sjajna tamnosiva Polished dark grey	1	12
44P03TR	Providna (personalizujuća) - rastavljena (vidi sl. ispod) Transparent customisable - to be assembled (see the fig. below)	Sjajnobela Ral 9010 (uključena) Sjajna tamnosiva (uključena) Ral 9010 white (included) Polished dark grey (included)	1	12

- Napomena:** ✓ 44P03TR za razliku od 44P03B isporučuje se rastavljena kako bi korisnik mogao da je personalizuje po svojoj želji. Ova maska isporučuje se u kompletu sa duplim unutrašnjim okvirom (sjajnobeli RAL9010 i sjajno tamnosivi) kao i sa šablonom za opsecanje slike ili tapete (vidi sliku ispod)
- ✓ 44P03B je iste boje kao i 44P03TR
- ✓ 44P03TR differently from 44P03B, has to be assembled in order to allow the customer to personalize it. Two inner frames (RAL9010 and polished dark grey), and the cutout template for wallpaper are included (see the figure below)
- ✓ 44P03B has the same coloration as 44P03TR



#### Način isporuke 44P03TR Conditions of supply 44P03TR

Koristi se sa armaturom  
To be used with



44A03

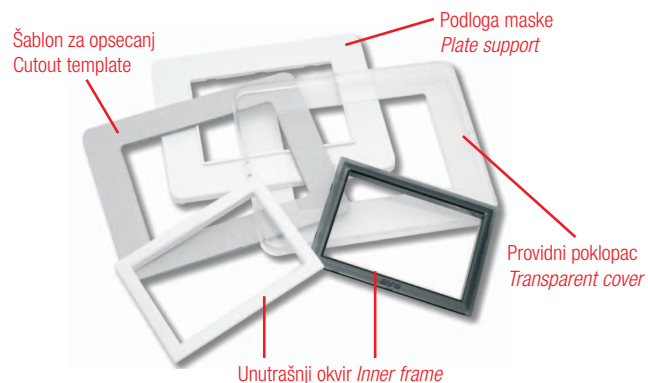

#### Izmenljivi unutrašnji okviri Spare inner frames

Kod Code	Boja Colour	Info	€
44CR3B	Sjajnobela Ral 9010 Ral 9010 white	2	50
44CR3N	Sjajna tamnosiva Polished dark grey	2	50
44CR3CR	Hrom Chrome	2	50



Za raspoloživost kontaktirajte  
Ave distributere  
For availability please contact  
sales dept.



Dostupni dok se ne  
rasprodaju zalihe  
Available until stock out



Proizvod za pravougaone  
kutije britanskog standarda  
Product for British standard  
rectangular box



Proizvod za  
izvoz  
For Export  
only

## Maske "Personal 44" za pravougaonu kutiju "Personal 44" front plates for rectangular box

4 MODULA 4 MODULES	Kod Code	Boja Colour	Unutrašnji okvir Inner frame	Info	€
	44P04AB	Narandžasta sjajna <i>Bright orange</i>	Sjajnobela Ral 9010 <i>Ral 9010 white</i>	1	10
	44P04ALS	Brušeni aluminijum <i>Natural aluminium</i>	Hrom <i>Chrome</i>	1	10
	44P04AZB	Azurnoplava <i>Bright light blue</i>	Sjajnobela Ral 9010 <i>Ral 9010 white</i>	1	10
	44P04B	Sjajnobela Ral 9010 <i>Ral 9010 polished white</i>	Sjajnobela Ral 9010 <i>Ral 9010 white</i>	1	10
	44P04BEL	Bež sjajna <i>Polished beige</i>	Sjajnobela Ral 9010 <i>Ral 9010 white</i>	1	10
	44P04CE	Svetloplava <i>Light blue</i>	Sjajnobela Ral 9010 <i>Ral 9010 white</i>	1	10
	44P04GRL	Sjajna tamnosiva <i>Polished dark grey</i>	Sjajnobela Ral 9010 <i>Ral 9010 white</i>	1	10
	44P04NAL	Sjajnocrna <i>Absolute black</i>	Hrom <i>Chrome</i>	1	10
	44P04RPL	Sjajnocrvena <i>Pompeian red</i>	Sjajna tamnosiva <i>Polished dark grey</i>	1	10

155



Sistema 45

Koristi se sa armaturom  
To be used with

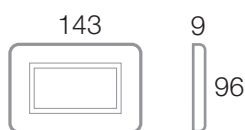

44A04

### Izmenljivi unutrašnji okviri Spare inner frames

	Kod Code	Boja Colour	Info	€
	44CR4B	Sjajnobela Ral 9010 <i>Ral 9010 white</i>	2	50
	44CR4N	Sjajna tamnosiva <i>Polished dark grey</i>	2	50
	44CR4CR	Hrom <i>Chrome</i>	2	50



# Maske

## Front Plates



Maske "Personal 44" za pravougaonu kutiju  
"Personal 44" front plates for rectangular box

156

7 MODULA 7 MODULES



Kod Code	Boja Colour	Unutrašnji okvir Inner frame	Info	€
44P07AB	Narandžasta sjajna <i>Bright orange</i>	Sjajnobela Ral 9010 <i>Ral 9010 white</i>	1	5
44P07ALS	Brušeni aluminijum <i>Natural aluminium</i>	Hrom <i>Chrome</i>	1	5
44P07AZB	Azurnoplava <i>Bright light blue</i>	Sjajnobela Ral 9010 <i>Ral 9010 white</i>	1	5
44P07B	Sjajnobela Ral 9010 <i>Ral 9010 polished white</i>	Sjajnobela Ral 9010 <i>Ral 9010 white</i>	1	5
44P07BEL	Bež sjajna <i>Polished beige</i>	Sjajnobela Ral 9010 <i>Ral 9010 white</i>	1	5
44P07CE	Svetloplava <i>Light blue</i>	Sjajnobela Ral 9010 <i>Ral 9010 white</i>	1	5
44P07GRL	Sjajna tamnosiva <i>Polished dark grey</i>	Sjajnobela Ral 9010 <i>Ral 9010 white</i>	1	5
44P07NAL	Sjajnocrna <i>Absolute black</i>	Hrom <i>Chrome</i>	1	5
44P07RPL	Sjajnocrvena <i>Pompeian red</i>	Sjajna tamnosiva <i>Polished dark grey</i>	1	5

Koristi se sa armaturom  
*To be used with*



44A07

### Izmenljivi unutrašnji okviri *Spare inner frames*



Kod Code	Boja Colour	Info	€
44CR7B	Sjajnobela Ral 9010 <i>Ral 9010 white</i>	2	30
44CR7N	Sjajna tamnosiva <i>Polished dark grey</i>	2	30
44CR7CR	Hrom <i>Chrome</i>	2	30



Za raspoloživost kontaktirajte  
Ave distributere  
For availability please contact  
sales dept.



Dostupni dok se ne  
rasprodaju zalihe  
Available until stock out



Proizvod za pravougaone  
kutije britanskog standarda  
Product for British standard  
rectangular box



Proizvod za  
izvoz  
For Export  
only

Maske "Personal 44" za kutiju BL02P  
"Personal 44" front plates for BL02P box

6(3+3) MODULIA 6(3+3) MODULES	Kod Code	Boja Colour	Unutrašnji okvir Inner frame	Info	€
	44P033AB	Narandžasta sjajna <i>Bright orange</i>	Sjajnobela Ral 9010 <i>Ral 9010 white</i>	1	5
	44P033ALS	Brušeni aluminijum <i>Natural aluminium</i>	Hrom <i>Chrome</i>	1	5
	44P033AZB	Azurnoplava <i>Bright light blue</i>	Sjajnobela Ral 9010 <i>Ral 9010 white</i>	1	5
	44P033B	Sjajnobela Ral 9010 <i>Ral 9010 polished white</i>	Sjajnobela Ral 9010 <i>Ral 9010 white</i>	1	5
	44P033BEL	Bež sjajna <i>Polished beige</i>	Sjajnobela Ral 9010 <i>Ral 9010 white</i>	1	5
	44P033CE	Svetloplava <i>Light blue</i>	Sjajnobela Ral 9010 <i>Ral 9010 white</i>	1	5
	44P033GRL	Sjajna tamnosiva <i>Polished dark grey</i>	Sjajnobela Ral 9010 <i>Ral 9010 white</i>	1	5
	44P033NAL	Sjajnocrna <i>Absolute black</i>	Hrom <i>Chrome</i>	1	5
	44P033RPL	Sjajnocrvena <i>Pompeian red</i>	Sjajna tamnosiva <i>Polished dark grey</i>	1	5

157



Sistema 45

Koristi se sa armaturom  
*To be used with*

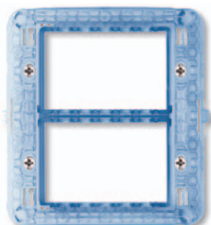
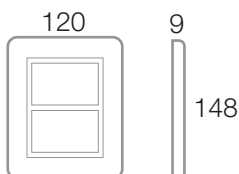

44A33

Izmenljivi unutrašnji okviri *Spare inner frames*

	Kod Code	Boja Colour	Info	€
	44CR33B	Sjajnobela Ral 9010 <i>Ral 9010 white</i>	2	50
	44CR33N	Sjajna tamnosiva <i>Polished dark grey</i>	2	50
	44CR33CR	Hrom <i>Chrome</i>	2	50
	44CR33CR/AP	Hrom - verzija bez prečke, koristi se za zvučnike 441AP01 ili 442AP01 <i>Chrome - version without central cross bar to be used with 441AP01 or 442AP01 speakers</i>	2	50





# Maske

## Front Plates

Promotivni materijal i oprema  
Promotional accessories and instruments

158



SWPERSONAL44



PERSONAL/3M



PERSONAL/VM

Kod Code	Opis Description	Info	€
SWPERSONAL44	Softver za personalizovanje maski "Personal 44" Software to customize "Personal 44" plates	-	--
PERSONAL/3M	Komplet od 30 kartica za personalizaciju - 3 modula Set of 30 customizable cards - 3 modules	1	1
PERSONAL/VM	Komplet od 30 kartica za personalizaciju - 4 modula, 7 modula, 6(3+3) modula Set of 30 customizable cards - 4 modules, 7 modules, 6(3+3) modules	1	1
VALIGETTA/S44	Funkcionalan kofer sa uzorcima Sistem 44 - serije Domus Touch, Life Touch i Allumia Touch Working sample case System 44 - Domus Touch, Life Touch and Allumia Touch series	1	1
VALIGETTA/NEW	Standardni kofer sa uzorcima Sistem 44 - serije Domus Touch, Life Touch i Allumia Touch Sample case System 44 - Domus Touch, Life Touch and Allumia Touch	1	1
VALIGETTA/BASE	Standardni kofer sa uzorcima Sistem 44 - serije Domus Touch i Allumia Touch Sample case - Domus Touch and Allumia Touch	1	1



VALIGETTA/S44



VALIGETTA/NEW



VALIGETTA/BASE

### Primeri personalizacije Examples for customization

Podloga maske  
Plate support

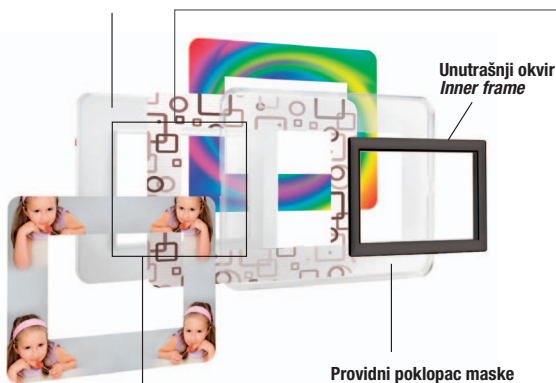

Kartice za personalizaciju  
Customizable cards



Primer personalizacije sa tapetama  
Example of customization with wallpaper



Za raspoloživost kontaktirajte  
Ave distributere  
For availability please contact  
sales dept.



Dostupni dok se ne  
rasprodaju zalihe  
Available until stock out



Proizvod za pravougaone  
kutije britanskog standarda  
Product for British standard  
rectangular box



Proizvod za  
izvoz  
For Export  
only

Maske "Tecnopolimero 44" 80x80 mm za okruglu ili kvadratnu kutiju  
 "44 moulded" 80x80 mm front plates for square or round box

1 MODUL	1 MODULE	Kod Code	Boja Colour	Info	€
	44P31AO	Srebrna mat <i>Matt silver</i>	1	30	
	44P31AP	Narandžasta - poluprovidna <i>Opaline orange - semi-transparent</i>	1	30	
	44P31B	Sjajnobela Ral 9010 <i>Ral 9010 white</i>	1	30	
	44P31CHO	Šampanj mat <i>Matt champagne</i>	1	30	
	44P31GD	Boja žada poluprovidna <i>Opaline jade - semi-transparent</i>	1	30	
	44P31GSL	Sjajna tamnosiva (boja LIFE 44) <i>Polished dark grey (LIFE 44 colour)</i>	1	30	
	44P31GSM	Tamnosiva metalik <i>Metallic dark grey</i>	1	30	
	44P31M	Boja mermera <i>Marble</i>	1	30	
	44P31OT	Mesing sjajni <i>Polished brass</i>	1	30	
	44P31PS	Boja breskve - poluprovidna <i>Opaline peach - semi-transparent</i>	1	30	
	44P31RD	Koren ruže <i>Matt briarwood</i>	1	30	
	44P31SA	Boja peska 1013 <i>Ral 1013 sand</i>	1	30	

159



Sistema 45

Koristi se sa armaturom  
 To be used with

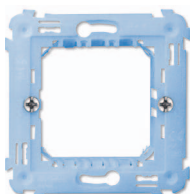
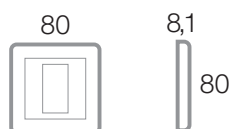

44A02  
 44A02SG  
 44A02VT



# Maske

## Front Plates



Maske "Tecnopolimero 44" 80x80 mm za okruglu ili kvadratnu kutiju  
 "44 moulded" 80x80 mm front plates for square or round box

160

2 MODULA 2 MODULES



Kod Code	Boja Colour	Info	€
44P32ALS	Brušeni aluminijum - hromirani unutrašnji okvir <i>Natural aluminium - chrome inner frame</i>	1	30
44P32AO	Srebrna mat <i>Matt silver</i>	1	30
44P32AP	Narandžasta - poluprovodna <i>Opaline orange - semi-transparent</i>	1	30
44P32B	Sjajnobela Ral 9010 <i>Ral 9010 white</i>	1	30
44P32BLC	Sjajnobela Ral 9010 - hromirani unutrašnji okvir <i>Ral 9010 white - chrome inner frame</i>	1	30
44P32CHO	Šampanj mat <i>Matt champagne</i>	1	30
44P32GD	Boja žada - poluprovodna <i>Opaline jade - semi-transparent</i>	1	30
44P32GSL	Sjajna tamnosiva (boja LIFE 44) <i>Polished dark grey (LIFE 44 colour)</i>	1	30
44P32GSM	Tamnosiva metalik <i>Metallic dark grey</i>	1	30
44P32M	Boja mermera <i>Marble</i>	1	30
44P32NAL	Sjajnocrna - hromiran unutrašnji okvir <i>Absolute black - chrome inner frame</i>	1	30
44P32OT	Mesing sjajni <i>Polished brass</i>	1	30
44P32PS	Boja breskve - poluprovodna <i>Opaline peach - semi-transparent</i>	1	30
44P32RD	Koren ruže <i>Matt briarwood</i>	1	30
44P32SA	Boja peska Ral 1013 <i>Ral 1013 sand</i>	1	30

Koristi se sa armaturom  
 To be used with

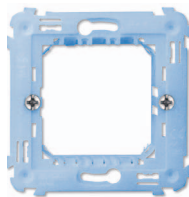

44A02  
 44A02SG  
 44A02VT



Za raspoloživost kontaktirajte  
 Ave distributere  
 For availability please contact  
 sales dept.



Dostupni dok se ne  
 rasprodaju zalihе  
 Available until stock out





Proizvod za pravougaone  
 kutije britanskog standarda  
 Product for British standard  
 rectangular box

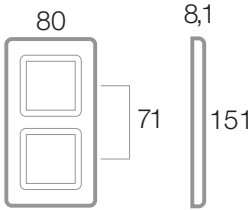

Proizvod za  
 izvoz  
 For Export  
 only

## Maske "Tecnopolimero 44" za okruglu ili kvadratnu kutiju "44 moulded" front plates for square or round box

4(2+2) MODULA 4(2+2) MODULES	Kod Code	Boja Colour	Info	€
    <p>Koristi se sa armaturom To be used with</p>   <p>n° 2 44A02 n° 2 44A02SG n° 2 44A02VT</p>	44P34ALS	Brušeni aluminijum - hromirani unutrašnji okvir <i>Natural aluminium - chrome inner frame</i>	1	30
	44P34A0	Srebrna mat <i>Matt silver</i>	1	15
	44P34AP	Narandžasta - poluprovidna <i>Opaline orange - semi-transparent</i>	1	15
	44P34B	Sjajnobela Ral 9010 <i>Ral 9010 white</i>	1	15
	44P34BLC	Sjajnobela Ral 9010 - hromirani unutrašnji okvir <i>Ral 9010 white - chrome inner frame</i>	1	30
	44P34CHO	Šampanj mat <i>Matt champagne</i>	1	15
	44P34GD	Boja žada - poluprovidna <i>Opaline jade - semi-transparent</i>	1	15
	44P34GSL	Sjajna tamnosiva (boja LIFE 44) <i>Polished dark grey (LIFE 44 colour)</i>	1	15
	44P34GSM	Tamnosaiva metalik <i>Metallic dark grey</i>	1	15
	44P34M	Boja mermera <i>Marble</i>	1	15
	44P34NAL	Sjajnocrna - hromiran unutrašnji okvir <i>Absolute black - chrome inner frame</i>	1	30
	44P34OT	Mesing sjajni <i>Polished brass</i>	1	15
	44P34PS	Boja breskve - poluprovidna <i>Opaline peach - semi-transparent</i>	1	15
	44P34RD	Koren ruže <i>Matt briarwood</i>	1	15
	44P34SA	Boja peska Ral 1013 <i>Ral 1013 sand</i>	1	15

161



Sistema 45

### Način instaliranja Installation solution

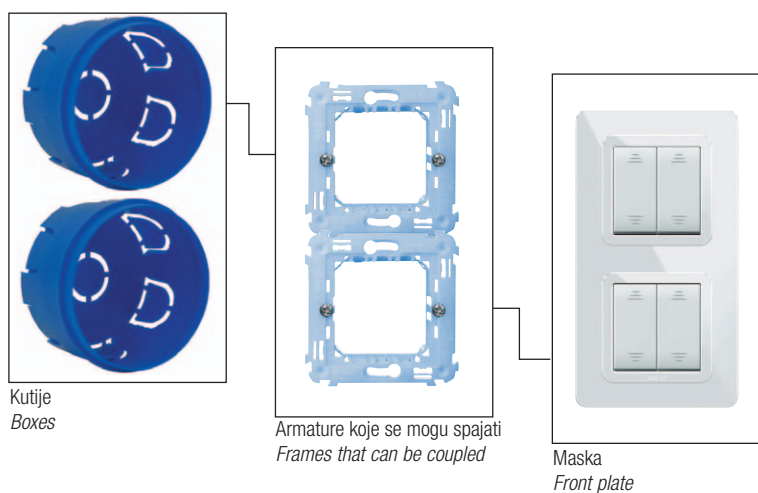
 Min. pakovanje kom.  
Min. Packaging pcs

 Stand. pakovanje kom.  
Std. Packaging pcs



# Maske

## Front Plates



### Maske "Tecnopolimero 44" za okruglu ili kvadratnu kutiju

#### "44 moulded" front plates for square or round box

162

6(2+2+2) MODULA 6(2+2+2) MODULES

Kod Code	Boja Colour	Info	€
44P36ALS	Brušeni aluminijum - hromirani unutrašnji okvir <i>Natural aluminium - chrome inner frame</i>	1	10
44P36A0	Srebrna mat <i>Matt silver</i>	1	10
44P36AP	Narandžasta - poluprovodna <i>Opaline orange - semi-transparent</i>	1	10
44P36B	Sjajnobela Ral 9010 <i>Ral 9010 white</i>	1	10
44P36BLC	Sjajnobela Ral 9010 - hromirani unutrašnji okvir <i>Ral 9010 white - chrome inner frame</i>	1	30
44P36CHO	Šampanj mat <i>Matt champagne</i>	1	10
44P36GD	Boja žada - poluprovodna <i>Opaline jade - semi-transparent</i>	1	10
44P36GSL	Sjajna tamnosiva (boja LIFE 44) <i>Polished dark grey (LIFE 44 colour)</i>	1	10
44P36GSM	Tamnosa metalik <i>Metallic dark grey</i>	1	10
44P36M	Boja mermera <i>Marble</i>	1	10
44P36NAL	Sjajnocrna - hromiran unutrašnji okvir <i>Absolute black - chrome inner frame</i>	1	10
44P36OT	Mesing sjajni <i>Polished brass</i>	1	10
44P36PS	Boja breskve - poluprovodna <i>Opaline peach - semi-transparent</i>	1	10
44P36RD	Koren ruže <i>Matt briarwood</i>	1	10
44P36SA	Boja peska Ral 1013 <i>Ral 1013 sand</i>	1	10

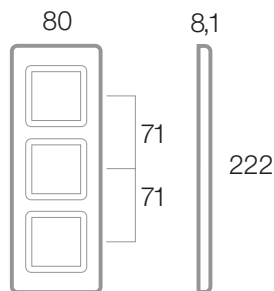

Koristi se sa armaturom  
*To be used with*

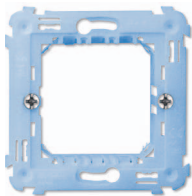

n° 3 44A02  
n° 3 44A02SG  
n° 3 44A02VT

### Način instaliranja Installation solution



Kutije  
*Boxes*

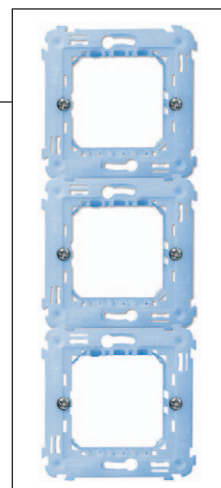

Armature koje se mogu spajati  
*Frames that can be coupled*



Maska Front plate



Za raspoloživost kontaktirajte  
Ave distributere  
For availability please contact  
sales dept.



Dostupni dok se ne  
rasprodaju zalihe  
Available until stock out



Proizvod za pravougaone  
kutije britanskog standarda  
Product for British standard  
rectangular box



Proizvod za  
izvoz  
For Export  
only

## Maske "Tecnopolimero 44" 88x88 mm za okruglu ili kvadratnu kutiju "44 moulded" 88x88 mm front plates for square or round box

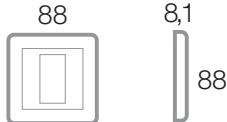
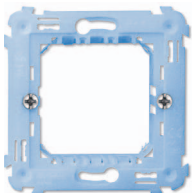
1 MODUL	1 MODULE	Kod Code	Boja Colour	Info	€
  Koristi se sa armaturom <i>To be used with</i>  44A02 44A02SG 44A02VT	44PY31A0	Srebrna mat <i>Matt silver</i>	1	30	
	44PY31AP	Narandžasta - poluprovodna <i>Opaline orange - semi-transparent</i>	1	30	
	44PY31B	Sjajnobela Ral 9010 <i>Ral 9010 white</i>	1	30	
	44PY31CHO	Šampanj mat <i>Matt champagne</i>	1	30	
	44PY31GD	Boja žada - poluprovodna <i>Opaline jade - semi-transparent</i>	1	30	
	44PY31GSL	Sjajna tamnosiva (boja LIFE 44) <i>Polished dark grey (LIFE 44 colour)</i>	1	30	
	44PY31GSM	Tamnosaiva metalik <i>Metallic dark grey</i>	1	30	
	44PY31M	Boja mermera <i>Marble</i>	1	30	
	44PY31OT	Mesing sjajni <i>Polished brass</i>	1	30	
	44PY31PS	Boja breskve - poluprovodna <i>Opaline peach - semi-transparent</i>	1	30	
	44PY31RD	Koren ruže <i>Matt briarwood</i>	1	30	
	44PY31SA	Boja peska Ral 1013 <i>Ral 1013 sand</i>	1	30	

163



Sistema 45

## Maske "Tecnopolimero 44" 88x88 mm za okruglu ili kvadratnu kutiju "44 moulded" 88x88 mm front plates for square or round box

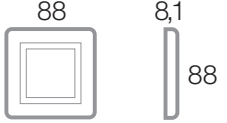
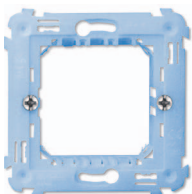
2 MODULA	2 MODULES	Kod Code	Boja Colour	Info	€
  Koristi se sa armaturom <i>To be used with</i>  44A02 44A02SG 44A02VT	44PY32A0	Srebrna mat <i>Matt silver</i>	1	30	
	44PY32AP	Narandžasta - poluprovodna <i>Opaline orange - semi-transparent</i>	1	30	
	44PY32B	Sjajnobela Ral 9010 <i>Ral 9010 white</i>	1	30	
	44PY32CHO	Šampanj mat <i>Matt champagne</i>	1	30	
	44PY32GD	Boja žada - poluprovodna <i>Opaline jade - semi-transparent</i>	1	30	
	44PY32GSL	Sjajna tamnosiva (boja LIFE 44) <i>Polished dark grey (LIFE 44 colour)</i>	1	30	
	44PY32GSM	Tamnosaiva metalik <i>Metallic dark grey</i>	1	30	
	44PY32M	Boja mermera <i>Marble</i>	1	30	
	44PY32OT	Mesing sjajni <i>Polished brass</i>	1	30	
	44PY32PS	Boja breskve - poluprovodna <i>Opaline peach - semi-transparent</i>	1	30	
	44PY32RD	Koren ruže <i>Matt briarwood</i>	1	30	
	44PY32SA	Boja peska Ral 1013 <i>Ral 1013 sand</i>	1	30	

 Min. pakovanje kom.  
Min. Packaging pcs

 Stand. pakovanje kom.  
Std. Packaging pcs





# Maske

## Front Plates

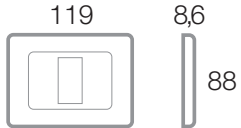

### Maske "Tecnopolimero 44" za pravougaonu kutiju "44 moulded" front plates for rectangular box

164

1 MODUL	1 MODULE	Kod Code	Boja Colour	Info	€
  <p>Koristi se sa armaturom To be used with</p> 	44PY01A0	Srebrna mat Matt silver	1	25	
	44PY01AP	Narandžasta - poluprovodna Opaline orange - semi-transparent	1	25	
	44PY01B	Sjajnobela Ral 9010 Ral 9010 white	1	25	
	44PY01CHO	Šampanj mat Matt champagne	1	25	
	44PY01GD	Boja žada - poluprovodna Opaline jade - semi-transparent	1	25	
	44PY01GSL	Sjajna tamnosiva (boja LIFE 44) Polished dark grey (LIFE 44 colour)	1	25	
	44PY01GSM	Tamnosiva metalik Metallic dark grey	1	25	
	44PY01M	Boja mermera Marble	1	25	
	44PY01OT	Mesing sjajni Polished brass	1	25	
	44PY01PS	Boja breskve - poluprovodna Opaline peach - semi-transparent	1	25	
	44PY01RD	Koren ruže Matt briarwood	1	25	
	44PY01SA	Boja peska Ral 1013 Ral 1013 sand	1	25	

44A03

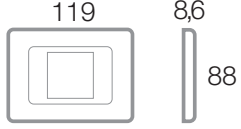
### Maske "Tecnopolimero 44" za pravougaonu kutiju "44 moulded" front plates for rectangular box

2 MODULA	2 MODULES	Kod Code	Boja Colour	Info	€
  <p>Koristi se sa armaturom To be used with</p> 	44PY02A0	Srebrna mat Matt silver	1	25	
	44PY02AP	Narandžasta - poluprovodna Opaline orange - semi-transparent	1	25	
	44PY02B	Sjajnobela Ral 9010 Ral 9010 white	1	25	
	44PY02CHO	Šampanj mat Matt champagne	1	25	
	44PY02GD	Boja žada - poluprovodna Opaline jade - semi-transparent	1	25	
	44PY02GSL	Sjajna tamnosiva (boja LIFE 44) Polished dark grey (LIFE 44 colour)	1	25	
	44PY02GSM	Tamnosiva metalik Metallic dark grey	1	25	
	44PY02M	Boja mermera Marble	1	25	
	44PY02OT	Mesing sjajni Polished brass	1	25	
	44PY02PS	Boja breskve - poluprovodna Opaline peach - semi-transparent	1	25	
	44PY02RD	Koren ruže Matt briarwood	1	25	
	44PY02SA	Boja peska Ral 1013 Ral 1013 sand	1	25	

44A03



Za raspoloživost kontaktirajte  
Ave distributere  
For availability please contact  
sales dept.



Dostupni dok se ne  
rasprodaju zalihe  
Available until stock out



Proizvod za pravougaone  
kutije britanskog standarda  
Product for British standard  
rectangular box



Proizvod za  
izvoz  
For Export  
only

## Maske "Tecnopolimero 44" za pravougaonu kutiju "44 moulded" front plates for rectangular box

3 MODULA 3 MODULES	Kod Code	Boja Colour	Info	€
	44PY03ALS	Brušeni aluminijum - hromirani unutrašnji okvir <i>Natural aluminium - chrome inner frame</i>		1 25
	44PY03AO	Srebrna mat <i>Matt silver</i>		1 25
	44PY03AP	Narandžasta - poluprovidna <i>Opaline orange - semi-transparent</i>		1 25
	44PY03B	Sjajnobela Ral 9010 <i>Ral 9010 white</i>		1 25
	44PY03BLC	Sjajnobela Ral 9010 - hromirani unutrašnji okvir <i>Ral 9010 white - chrome inner frame</i>		1 25
	44PY03CHO	Šampanj mat <i>Matt champagne</i>		1 25
	44PY03GD	Boja žada - poluprovidna <i>Opaline jade - semi-transparent</i>		1 25
	44PY03GSL	Sjajna tamnosiva (boja LIFE 44) <i>Polished dark grey (LIFE 44 colour)</i>		1 25
	44PY03GSM	Tamnosiva metalik <i>Metallic dark grey</i>		1 25
	44PY03M	Boja mermera <i>Marble</i>		1 25
	44PY03NAL	Sjajnocrna - hromiran unutrašnji okvir <i>Absolute Black - chrome inner frame</i>		1 25
	44PY03OT	Mesing sjajni <i>Polished brass</i>		1 25
	44PY03PS	Boja breskve - poluprovidna <i>Opaline peach - semi-transparent</i>		1 25
	44PY03RD	Koren ruže <i>Matt briarwood</i>		1 25
	44PY03SA	Boja peska Ral 1013 <i>Ral 1013 sand</i>		1 25

165



Sistema 45

Koristi se sa armaturom  
*To be used with*

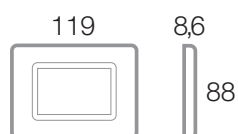

44A03





# Maske

## Front Plates

### Maske "Tecnopolimero 44" za pravougaonu kutiju "44 moulded" front plates for rectangular box

166

4 MODULA 4 MODULES



Kod Code	Boja Colour	Info	€
44PY04ALS	Brušeni aluminijum - hromirani unutrašnji okvir <i>Natural aluminium - chrome inner frame</i>	1	20
44PY04AO	Srebrna mat <i>Matt silver</i>	1	20
44PY04AP	Narandžasta - poluprovodna <i>Opaline orange - semi-transparent</i>	1	20
44PY04B	Sjajnobela Ral 9010 <i>Ral 9010 white</i>	1	20
44PY04BLC	Sjajnobela Ral 9010 - hromirani unutrašnji okvir <i>Ral 9010 white - chrome inner frame</i>	1	20
44PY04CHO	Šampanj mat <i>Matt champagne</i>	1	20
44PY04GD	Boja žada - poluprovodna <i>Opaline jade - semi-transparent</i>	1	20
44PY04GSL	Sjajna tamnosiva (boja LIFE 44) <i>Polished dark grey (LIFE 44 colour)</i>	1	20
44PY04GSM	Tamnosiva metalik <i>Metallic dark grey</i>	1	20
44PY04M	Boja mermera <i>Marble</i>	1	20
44PY04NAL	Sjajnocrna - hromiran unutrašnji okvir <i>Absolute Black - chrome inner frame</i>	1	20
44PY04OT	Mesing sjajni <i>Polished brass</i>	1	20
44PY04PS	Boja breskve - poluprovodna <i>Opaline peach - semi-transparent</i>	1	20
44PY04RD	Koren ruže <i>Matt briarwood</i>	1	20
44PY04SA	Boja peska Ral 1013 <i>Ral 1013 sand</i>	1	20

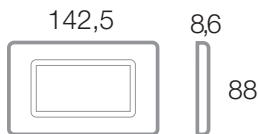

Koristi se sa armaturom  
*To be used with*

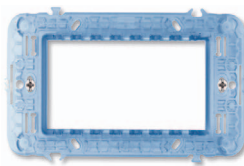

44A04



Za raspoloživost kontaktirajte  
Ave distributere  
For availability please contact  
sales dept.



Dostupni dok se ne  
rasprodaju zalihe  
Available until stock out



Proizvod za pravougaone  
kutije britanskog standarda  
Product for British standard  
rectangular box



Proizvod za  
izvoz  
For Export  
only

## Maske "Tecnopolimero 44" za pravougaonu kutiju "44 moulded" front plates for rectangular box

7 MODULA 7 MODULES	Kod Code	Boja Colour	Info	€
	44PY07ALS	Brušeni aluminijum - hromirani unutrašnji okvir <i>Natural aluminium - chrome inner frame</i>		1 15
	44PY07AO	Srebrna mat <i>Matt silver</i>		1 15
	44PY07AP	Narandžasta - poluprovidna <i>Opaline orange - semi-transparent</i>		1 15
	44PY07B	Sjajnobela Ral 9010 <i>Ral 9010 white</i>		1 15
	44PY07BLC	Sjajnobela Ral 9010 - hromirani unutrašnji okvir <i>Ral 9010 white - chrome inner frame</i>		1 15
	44PY07CHO	Šampanj mat <i>Matt champagne</i>		1 15
	44PY07GD	Boja žada - poluprovidna <i>Opaline jade - semi-transparent</i>		1 15
	44PY07GSL	Sjajna tamnosiva (boja LIFE 44) <i>Polished dark grey (LIFE 44 colour)</i>		1 15
	44PY07GSM	Tamnosa metalik <i>Metallic dark grey</i>		1 15
	44PY07M	Boja mermera <i>Marble</i>		1 15
	44PY07NAL	Sjajnocrna - hromiran unutrašnji okvir <i>Absolute Black - chrome inner frame</i>		1 15
	44PY07OT	Mesing sjajni <i>Polished brass</i>		1 15
	44PY07PS	Boja breskve - poluprovidna <i>Opaline peach - semi-transparent</i>		1 15
	44PY07RD	Koren ruže <i>Matt briarwood</i>		1 15
	44PY07SA	Boja peska Ral 1013 <i>Ral 1013 sand</i>		1 15

167



Sistema 45

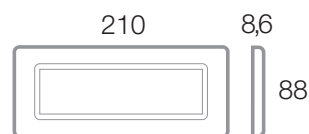

Koristi se sa armaturom  
To be used with



44A07



# Maske

## Front Plates

### Maske "Tecnopolimero 44" za kutiju BL02P "44 moulded" front plates for BL02P box

168

6(3+3) MODULA 6(3+3) MODULES	Kod Code	Boja Colour	Info	€
	44PY033A0	Srebrna mat <i>Matt silver</i>	1	5
	44PY033B	Sjajnobela Ral 9010 <i>Ral 9010 white</i>	1	5
	44PY033CHO	Šampanj mat <i>Matt champagne</i>	1	5
	44PY033GSL	Sjajna tamnosiva (boja LIFE 44) <i>Polished dark grey (LIFE 44 colour)</i>	1	5
	44PY033M	Boja mermera <i>Marble</i>	1	5
	44PY033SA	Boja peska Ral 1013 <i>Ral 1013 sand</i>	1	5

Koristi se sa armaturom  
*To be used with*

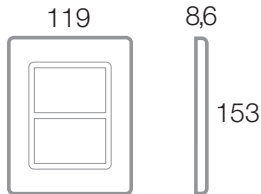

44A33

### Maske "Tecnopolimero 44" za kutiju BL05P i BL05CG "44 moulded" front plates for BL05P and BL05CG box

12(6+6) MODULA 12(6+6) MODULES	Kod Code	Boja Colour	Info	€
	44PY012A0	Srebrna mat <i>Matt silver</i>	1	5
	44PY012B	Sjajnobela Ral 9010 <i>Ral 9010 white</i>	1	5
	44PY012CHO	Šampanj mat <i>Matt champagne</i>	1	5
	44PY012GSL	Sjajna tamnosiva (boja LIFE 44) <i>Polished dark grey (LIFE 44 colour)</i>	1	5
	44PY012M	Boja mermera <i>Marble</i>	1	5
	44PY012SA	Boja peska Ral 1013 <i>Ral 1013 sand</i>	1	5

Koristi se sa armaturom  
*To be used with*

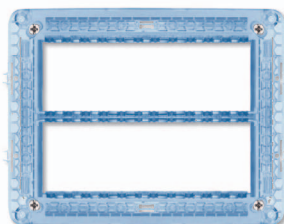
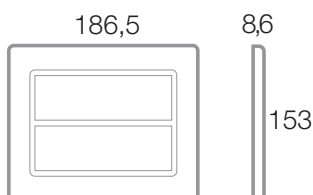

44A12



Za raspoloživost kontaktirajte  
Ave distributere  
For availability please contact  
sales dept.



Dostupni dok se ne  
rasprodaju zalihe  
Available until stock out



Proizvod za pravougaone  
kutije britanskog standarda  
Product for British standard  
rectangular box



Proizvod za  
izvoz  
For Export  
only

## Maske "Tecnopolimero 44" za panele i profile "44 moulded" front plates for section bars

169



1 MODUL	1 MODULE	Kod Code	Opis Description	Info	€
		44PF1AO	Srebrna mat <i>Matt silver</i>	1	50
		44PF1B	Sjajnobela Ral 9010 <i>Ral 9010 white</i>	1	50
		44PF1CHO	Šampanj mat <i>Matt champagne</i>	1	50
		44PF1GSL	Sjajna tamnosiva (boja LIFE 44) <i>Polished dark grey (LIFE 44 colour)</i>	1	50
		44PF1M	Boja mermera <i>Marble</i>	1	50
		44PF1SA	Boja peska Ral 1013 <i>Ral 1013 sand</i>	1	50

Koristi se sa armaturom  
*To be used with*

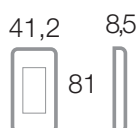

44A01

2(1+1) MODULA	2(1+1) MODULES	Kod Code	Boja Colour	Info	€
		44PF2AO	Srebrna mat <i>Matt silver</i>	1	30
		44PF2B	Sjajnobela Ral 9010 <i>Ral 9010 white</i>	1	30
		44PF2CHO	Šampanj mat <i>Matt champagne</i>	1	30
		44PF2GSL	Sjajna tamnosiva (boja LIFE 44) <i>Polished dark grey (LIFE 44 colour)</i>	1	30
		44PF2M	Boja mermera <i>Marble</i>	1	30
		44PF2SA	Boja peska Ral 1013 <i>Ral 1013 sand</i>	1	30

Koristi se sa armaturom  
*To be used with*

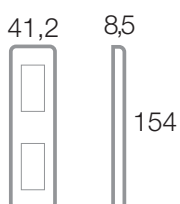

44A01

+

44A01



# Armature i kućišta

## Frames and Enclosures



### Armature za okrugle i kvadratne kutije

#### Frames for round and square boxes

170

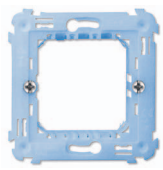
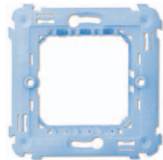
44A02  
44A02VT

44A02SG

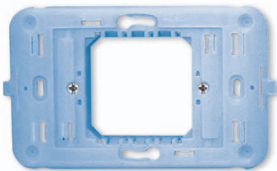

44A002

Kod Code	Opis Description	Info	€
44A02	Armatura za 1-2 modula za okruglu kutiju Ø 60 mm - sa bočnim žabicama - moguće je - vertikalno ili horizontalno spajanje pomoću šrafova na međusobnom rastojanju od 71 mm 1-2 modules frame for round box Ø 60 mm - couplable with centre distance 71 mm - with lateral clips	50	50
44A02SG	Armatura za 1-2 modula za okruglu kutiju - bez žabica i šrafova - moguće je vertikalno ili horizontalno spajanje pomoću šrafova na međusobnom rastojanju od 71 mm - može se montirati na kutije sa rastojanjem između šrafova od 60 mm ili 56x56 mm 1-2 modules frame for round box - without clips and without screws - couplable with centre distance 71mm - can be installed on boxes with centre distance of 60 mm or 56x56 mm	30	30
44A02VT	Armatura za 1-2 modula za okruglu ili kvadratnu kutiju - sa šrafovim zakačenim na armaturu - može se montirati na kutije sa rastojanjem između šrafova od 60 mm ili 56x56 mm 1-2 modules frame for round or square box - with screws hooked to the frame - can be installed on boxes with centre distance of 60 mm or 56x56 mm	30	30
44A002	Armatura za 1-2 modula za okruglu kutiju Ø 60 mm - sa bočnim žabicama - za pravougaone maske sa 1 ili 2 centralna modula 1-2 modules frame for round box Ø 60 mm - with clips - for rectangular front plates with 1 or 2 central modules	10	10

#### Modularnost - spajanje (u mm) Modularity (mm)

#### Sistem spajanja Coupling System

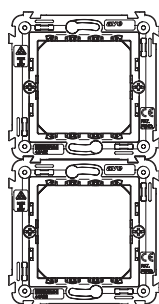
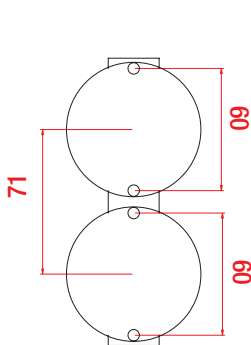
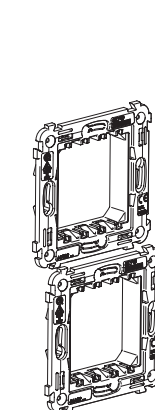
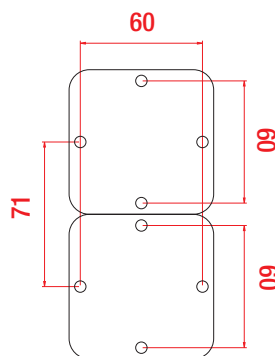
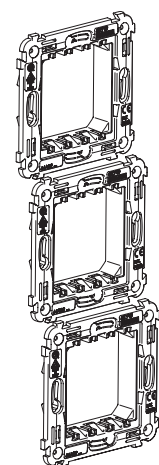
2 armature 44A02  
2 44A02 frames2 armature 44A02  
2 44A02 frames3 armature 44A02  
3 44A02 frames

#### Šablon za pravljenje otvora (in mm) Cutout Template (mm)

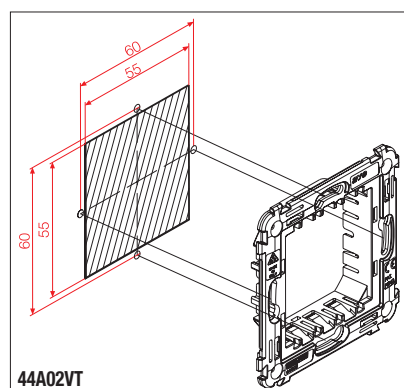

44A02VT

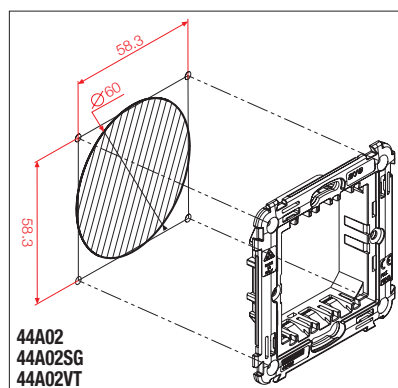
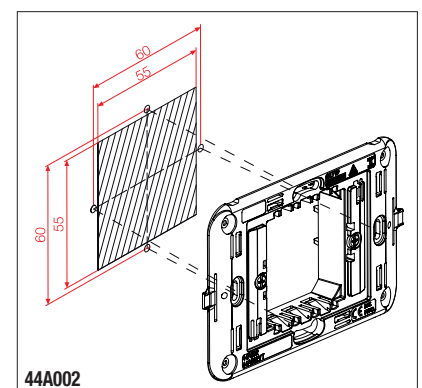
44A02  
44A02SG  
44A02VT

44A002



Za raspoloživost kontaktirajte Ave distributere  
For availability please contact sales dept.



Dostupni dok se ne rasprodaju zalihe  
Available until stock out



Proizvod za pravougaone kutije britanskog standarda  
Product for British standard rectangular box



Proizvod za izvoz  
For Export only

## Armature za pravougaone kutije Frames for rectangular boxes

	Kod Code	Opis Description	Info	€
	44A03	Armatura za 3 modula za kutije 2503MG, 253CG i 253GB - sa šrafovim <i>3 modules frame for 2503MG, 253CG and 253GB boxes - with screws</i>		120 120
44A03	44A002VT	Armatura za 1-2 centralna modula za kutije 2503MG, 253CG, 253GB i za okrugle ili kvadratne kutije sa rastojanjem između šrafova od 60 mm ili 56x56 mm - sa šrafovim - za pravougaone maske sa 1 ili 2 centralna modula <i>1-2 central modules frame for 2503MG, 253CG, 253GB boxes and round or square boxes with centre distance of 60 mm or 56x56 mm - with screws - for rectangular front plates 1 or 2 central modules</i>		10 10
	44A/45B	Armatura adapter za 3 modula iz Sistema 44 za maske iz Sistema 45 - bela boja RAL 9010 - za kutije 2503MG, 253CG i 253GB - sa šrafovim <i>3 modules frame for S45 front plates - RAL 9010 white colour - for 2503MG, 253CG and 253GB boxes - with screws</i>		10 10
44A002VT	44A/45B2	Armatura adapter za 1-2 modula iz Sistema 44 za pravougaone maske iz Sistema 45 sa 1 ili 2 c modula - bela boja RAL 9010 - za kutije 2503MG, 253CG, 253GB i za okrugle ili kvadratne kutije sa rastojanjem između šrafova od 60 mm ili 56x56 mm - sa šrafovim <i>1-2 modules frame for S45 rectangular front plates with 1 or 2 central modules - colour RAL 9010 white - for 2503MG, 253CG, 253GB boxes and round or square boxes with centre distance of 60 mm or 56x56 mm - with screws</i>		10 10
	44A/45B			
	44A/45B2			



Armatura adapter 44A/45B sa maskom Spring Sistema 45  
Frame 44A/45B with Spring System 45 plate

### Šablon za pravljenje otvora (u mm) Cutout Template (mm)

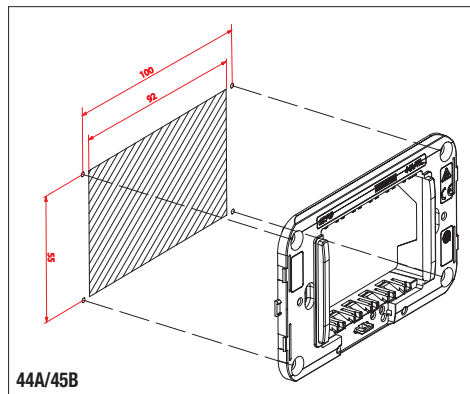
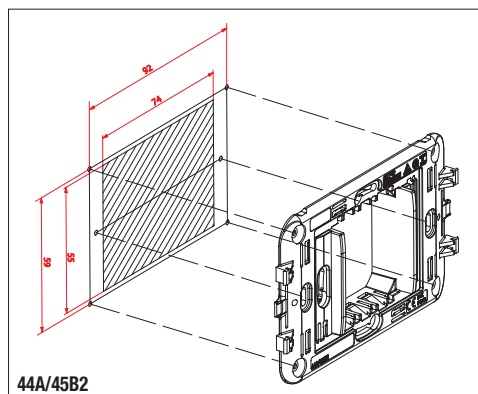
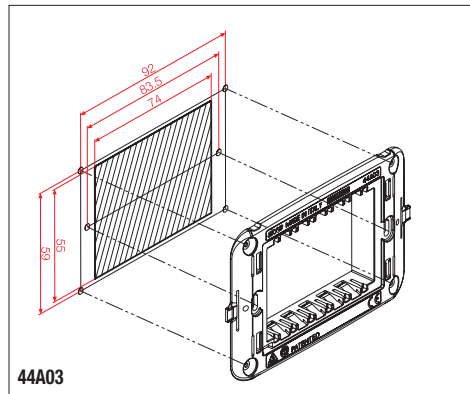
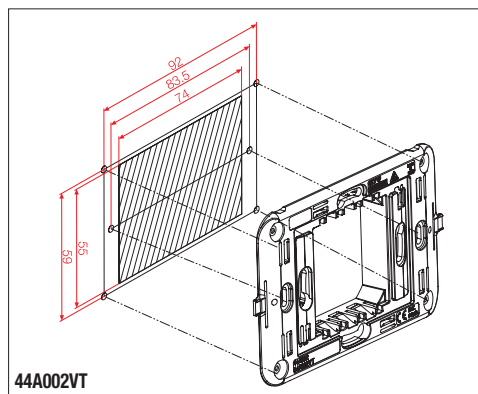



# Armature i kućišta

## Frames and Enclosures

### Armature za pravougaone kutije Frames for rectangular boxes



172

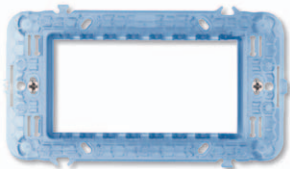

44A04

Kod Code	Opis Description	Info	€
44A04	Armatura za 4 modula za kutiju 2504 i 254CG - sa šrafovim 4 modules frame for 2504 and 254CG boxes - with screws	15	15
44A07	Armatura za 7 modula za kutiju 2506 i 256CG - sa šrafovim 7 modules frame for 2506 and 256CG boxes - with screws	8	8



44A07

#### Šablon za pravljenje otvora (u mm) Cutout Template (mm)

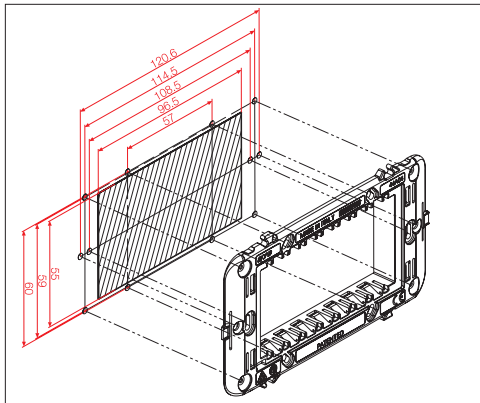

44A04

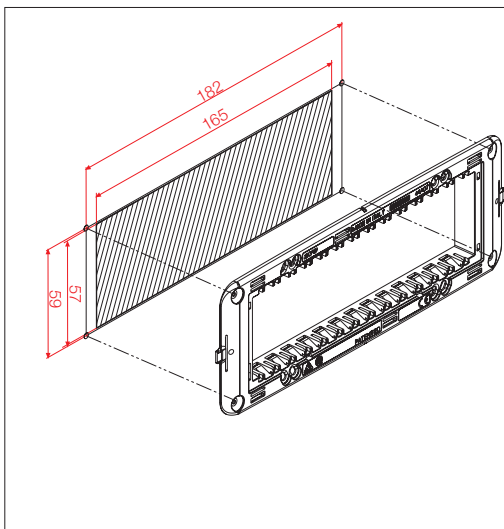

44A07

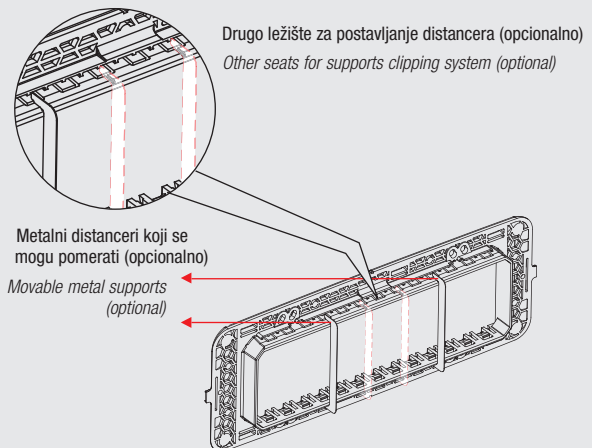

Za raspoloživost kontaktirajte  
Ave distributere  
For availability please contact  
sales dept.



Dostupni dok se ne  
rasprodaju zalihe  
Available until stock out



Proizvod za pravougaone  
kutije britanskog standarda  
Product for British standard  
rectangular box



Proizvod za  
izvoz  
For Export  
only

## Armatura za kutiju BL02P Frame for BL02P box

173

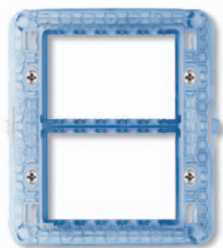

44A33

Kod Code	Opis Description	Info	€
44A33	Armatura 6(3+3) modula za kutiju BL02P - separator se može ukloniti - sa šrafovim 6(3+3) modules frame for BL02P box - removable separator - with screws	8	8

Šablon za pravljenje otvora (u mm) Cutout Template (mm)

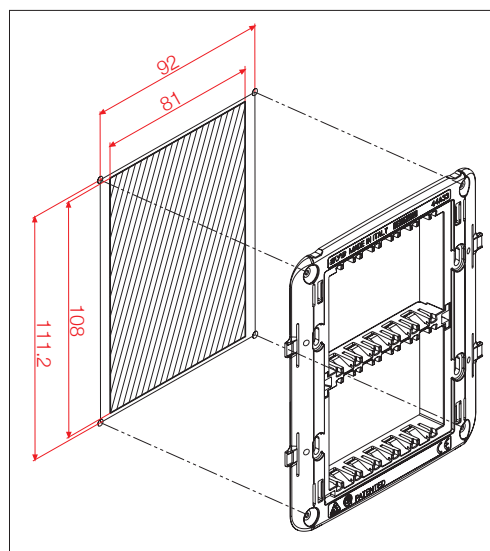

44A33

## Armatura za kutiju BL05P i BL05CG Frame for BL05P and BL05CG box



44A12

Kod Code	Opis Description	Info	€
44A12	Armatura za 12(6+6) modula za kutiju BL05P i BL05CG - separator se može ukloniti - sa šrafovim 12(6+6) modules frame for BL05P and BL05CG box - removable separator - with screws	1	1

Šablon za pravljenje otvora (in mm) Cutout Template (mm)

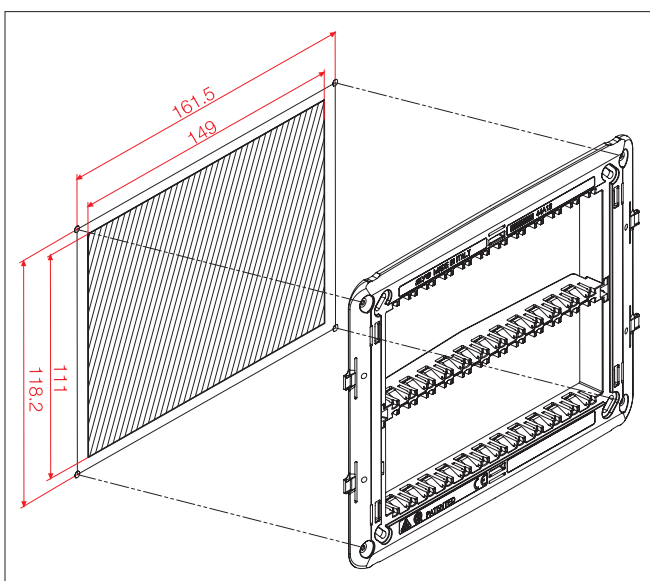

44A12



Sistema 45

Min. pakovanje kom.  
Min. Packaging pcs

Stand. pakovanje kom.  
Std. Packaging pcs





# Armature i kućišta

## Frames and Enclosures



### Armatura za panele i profile

#### Frame for section bars

174



44A01



Mogu se spajati  
Coupling possibility

44A01

+

44A01

Kod	Code	Opis	Description	Info	€
44A01		Armatura za 1 modul za panele/profile koja se može vertikalno spajati - sa šrafovim	1 module frame for section bars couplable in vertical - with screws	10	10

#### Šablon za pravljenje otvora (u mm) Cutout Template (mm)

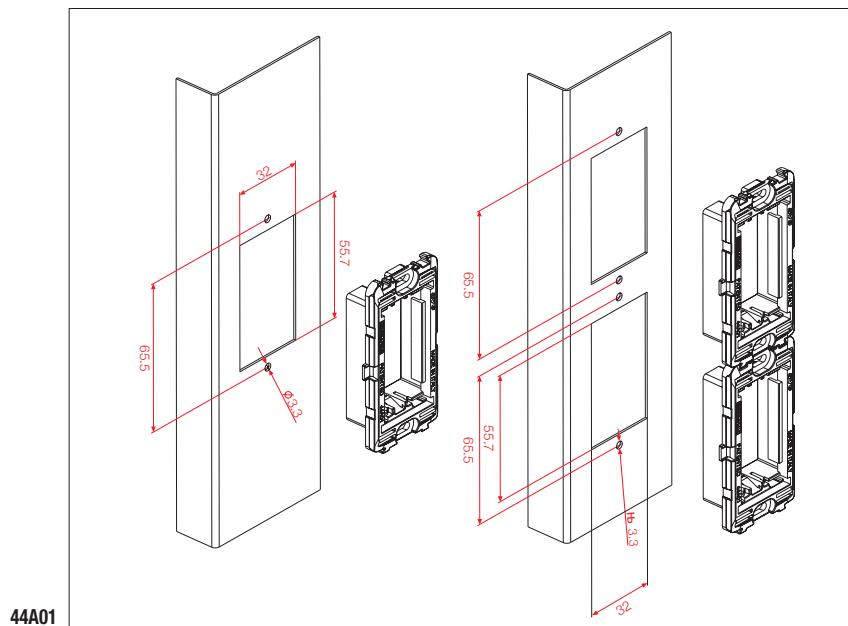

#### Dodatna oprema Accessories

Kod	Code	Opis	Description	Info	€
442PP		Providni poklopac za zaštitu prilikom krećenja - može se postaviti na armaturu 44A03	Transparent protection cover for painting - suitable for frame 44A03	50	50
VL0922		Šraf dužine 35 mm za fiksiranje armature na ugradnu kutiju	Long screw 35 mm to fix frames onto boxes set below plaster level	10	100
VL0923		Šraf dužine 48 mm za fiksiranje armature na ugradnu kutiju	Long screw 48 mm to fix frames onto boxes set below plaster level	100	100

442PP



VL0922



VL0923



Za raspoloživost kontaktirajte  
Ave distributere  
For availability please contact  
sales dept.



Dostupni dok se ne  
rasprodaju zalihe  
Available until stock out



Proizvod za pravougaone  
kutije britanskog standarda  
Product for British standard  
rectangular box



Proizvod za  
izvoz  
For Export  
only

## Nadgradno kućište IP40 za kanalice RAL 9010 bele boje RAL 9010 self-supporting enclosures IP40 for mini trunkings

175



44QC01



44QC02



44QC03

Kod Code	Opis Description	Info	€
44QC01	Nadgradno kućište IP40 za 1 modul S44 - za kanalice dimenzija od 20x10 mm do 30x18 mm - - montaža baze i poklopca pomoću 2 šrafa <i>1 module S44 - for mini trunkings from 20x10 mm to 30x18 mm - fixing of base/cover with 2 screws</i>	24	24
44QC02	Nadgradno kućište IP40 za 2 modula S44 - za kanalice dimenzija od 20x10 mm do 30x18 mm - - montaža baze i poklopca pomoću 2 šrafa <i>2 modules S44 - for mini trunkings from 20x10 mm to 30x18 mm - fixing of base/cover with 2 screws</i>	24	24
44QC03	Nadgradno kućište IP40 za 3 modula S44 - za kanalice dimenzija od 20x10 mm do 30x18 mm - - montaža baze i poklopca pomoću 2 šrafa <i>3 modules S44 - for mini trunkings from 20x10 mm to 30x18 mm - fixing of base/cover with 2 screws</i>	20	20

**Napomena:** postavljanje i skidanje uređaja vrši se sa zadnje strane poklopca  
**Note:** devices coupling and removal from the rear part

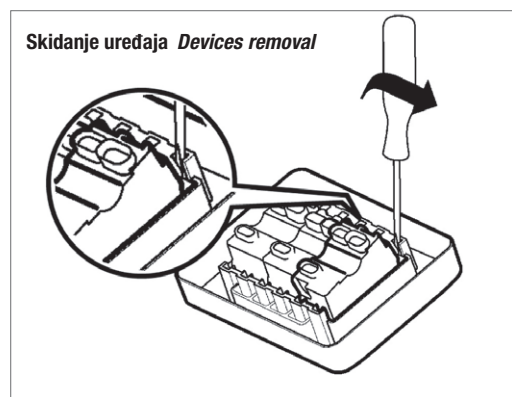

Dimenzije (u mm)

Dimensions (mm)

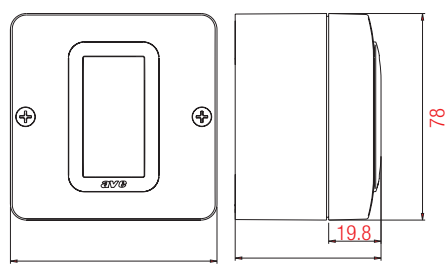

44QC01

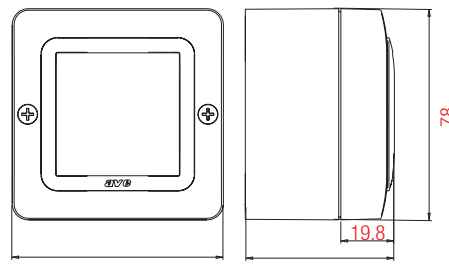

44QC02

Dimenzije (u mm)

Dimensions (mm)

Izgled sa zadnje strane Rear View

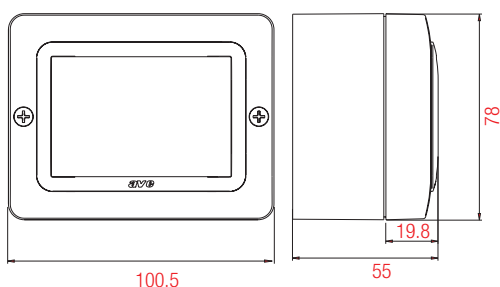

44QC03

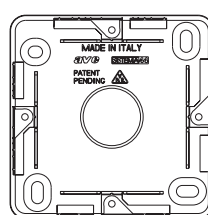

44QC01 - 44QC02

Min. pakovanje kom.  
Min. Packaging pcs

Stand. pakovanje kom.  
Std. Packaging pcs



# Armature i kućišta

## Frames and Enclosures



### Univerzalne kutije IP40 za kanalice RAL 9010 bele boje

#### RAL 9010 Universal boxes IP40 for mini trunkings

176



44SC03

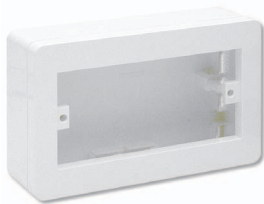

44SC04

Kod Code	Opis Description	Info	€
44SC03	Univerzalna nadgradna kutija IP40 za 3 modula - koristi se sa standardnom armaturom za 3 modula (rastojanje između šrafova 83,5 mm) - za kanalice dimezija od 20x10 mm do 30x18 mm <i>3 modules - to be used with standard 3 module frames (centre distance 83,5 mm) for trunking from 20x10 mm to 30x18 mm</i>	1	20
44SC04	Univerzalna nadgradna kutija IP40 za 4 modula - koristi se sa standardnom armaturom za 4 modula (rastojanje između šrafova 108 mm) - za kanalice od 20x10 mm do 30x18 mm <i>4 modules - to be used with standard 4 module frames (centre distance 108 mm) for trunking from 20x10 mm to 30x18 mm</i>	1	15

**Napomena:** pogodne su i za maske iz Sistema 45

**Note:** suitable also for System 45 front plates

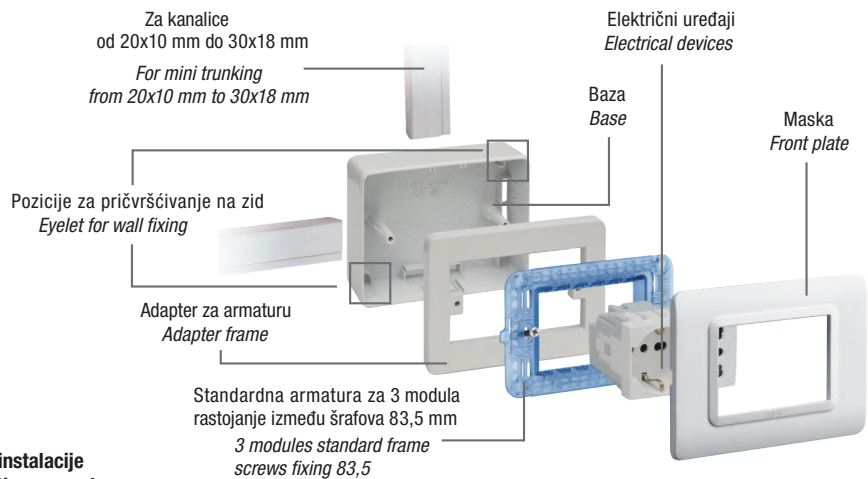

**Primer instalacije**  
**Installation example**

### Dotatna oprema za kućišta i kanalice

### Accessory for enclosures and boxes for mini trunkings

Kod Code	Opis Description	Info	€
45MM03	Priključak za uzemljenje <i>Earth terminal</i>	0,60 500	500



45MM03

### Dimenzije (u mm)

### Dimensions (mm)

### Izgled sa zadnje strane Rear View

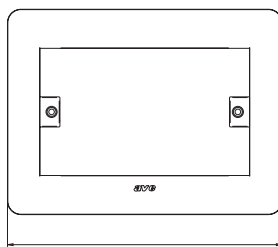

44SC03

123



46.5

76

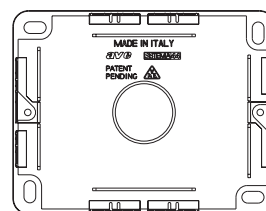

44SC03

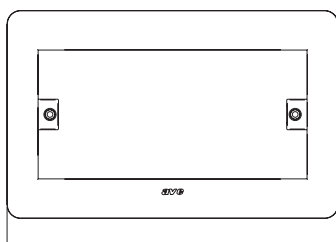

44SC04

146.5



46.5

92

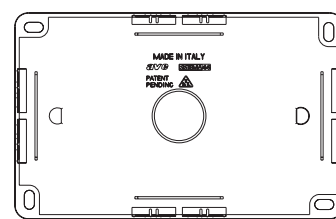

44SC04



Za raspoloživost kontaktirajte  
Ave distributere  
For availability please contact  
sales dept.



Dostupni dok se ne  
rasprodaju zalihe  
Available until stock out



Proizvod za pravougaone  
kutije britanskog standarda  
Product for British standard  
rectangular box



Proizvod za  
izvoz  
For Export  
only

## Kutija IP40 za maske "Vera 44", RAL9010 bele boje RAL 9010 boxes IP40 for "Vera 44" front plates

Kod Code	Opis Description	Info	€
44S33	Nadgradna kutija za 3+3 modula smanjene dubine - može se koristiti sa armaturom 44A33 - kompletirati sa maskom "Vera 44" 44PV33..., 44PA33..., 44PL33... - boja RAL9010  <i>Wall mounted 3+3 modules with reduced depth - to be used with 44A33 - to be completed with "Vera 44" plates 44PV33..., 44PA33..., 44PL33... - colour RAL9010</i>	1	1

44S33

### Dimenzije (u mm) Dimensions (mm)

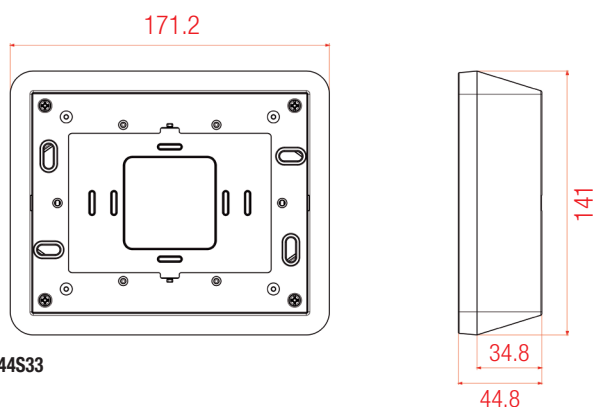

44S33

### Nosači za DIN EN 50022 šinu Supports for DIN EN 50022 rail

Kod Code	Opis Description	Info	€
53/44	Nosač za 1 modul S44 za postavljanje na DIN EN 50022 šinu - veličina 1,5 Din modul od 17,5 mm - boja RAL7035  <i>1 module adapter to install S44 on DIN EN 50022 rail - takes 1,5 DIN modules of 17,5 mm - colour RAL7035</i>	20	20
53/44/2	Nosač za 2 modula S44 za postavljanje na DIN EN 50022 šinu - veličina 3 modula DIN od 17,5 mm - boja RAL7035  <i>3 modules adapter to install S44 on DIN EN 50022 rail - takes 3 DIN modules of 17,5 mm - colour RAL7035</i>	8	8

53/44



53/44/2

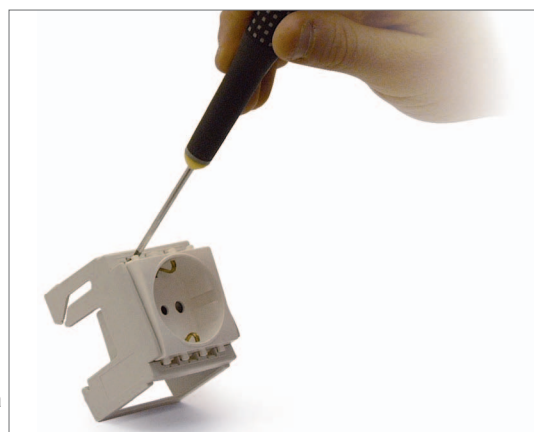

Skidanje uređaja  
Devices removal

Min. pakovanje kom.  
Min. Packaging pcs

Stand. pakovanje kom.  
Std. Packaging pcs



# Armature i kućišta

## Frames and Enclosures



### Samonoseće maske otporne na vodu IP55 sa silikonskim poklopcem

#### IP55 splashproof front plates with soft membrane cover - self-supporting

178



44SP02B

Sistem blokiranja otvorenog poklopa  
OPEN BLOCK  
Locking system of the door open

Kod Code	Opis Description	Info	€
44SP02B	Maska 2 modula S44 - fiksiranje pomoću bočnih žabica na okruglu kutiju Ø 60 mm - bela boja RAL9010 2 modules front plate - to be fixed by lateral clips on round box Ø 60mm - RAL 9010 white colour	<b>Novo</b>	2 2



44SP02GSL

Sistem blokiranja otvorenog poklopa  
OPEN BLOCK  
Locking system of the door open

44SP02GSL	Maska 2 modula S44 - fiksiranje pomoću bočnih žabica na okruglu kutiju Ø 60 mm - sjajna tamnosiva boja 2 modules front plate - to be fixed by lateral clips on round box Ø 60mm - polished dark grey	<b>Novo</b>	2 2
-----------	---	-------------	-----



44SP03B

Sistem blokiranja otvorenog poklopa  
OPEN BLOCK  
Locking system of the door open

44SP03B	Maska 3 modula S44 - fiksiranje pomoću šrafova na pravougaonu kutiju za 3 modula - bela boja RAL9010 3 modules front plate - to be fixed by screws on standard 3 modules rectangular box - RAL 9010 white colour	<b>Novo</b>	1 6
---------	---	-------------	-----



44SP03GSL

Sistem blokiranja otvorenog poklopa  
OPEN BLOCK  
Locking system of the door open

44SP03GSL	Maska 3 modula S44 - fiksiranje pomoću šrafova na pravougaonu kutiju za 3 modula - sjajna tamnosiva boja 3 modules front plate - to be fixed by screws on standard 3 modules rectangular box - polished dark grey	<b>Novo</b>	1 6
-----------	--	-------------	-----



44SP04B

Sistem blokiranja otvorenog poklopa  
OPEN BLOCK  
Locking system of the door open

44SP04B	Maska 4 modula S44 - fiksiranje pomoću šrafova na pravougaonu kutiju za 4 modula - bela boja RAL9010 4 modules front plate - to be fixed by screws on standard 4 modules rectangular box - RAL 9010 white colour	<b>Novo</b>	1 1
---------	---	-------------	-----



44SP04GSL

Sistem blokiranja otvorenog poklopa  
OPEN BLOCK  
Locking system of the door open

44SP04GSL	Maska 4 modula S44 - fiksiranje pomoću šrafova na pravougaonu kutiju za 4 modula - sjajna tamnosiva boja 4 modules front plate - to be fixed by screws on standard 4 modules rectangular box - polished dark grey	<b>Novo</b>	1 1
-----------	--	-------------	-----

**Napomena:** ✓ stepen zaštite IP55 je garantovan na vodootpornim zidovima i pločicama sa neravnim površinama i brazdama do dubine od 2 mm

✓ stepen zaštite IP55 je garantovan uz upotrebu komandnih uređaja i drugih modularnih uređaja koji omogućavaju da poklopac ostane zatvoren za vreme uobičajenog rada

**Notes:** ✓ IP55 protection degree guaranteed on waterproof walls and tiles with irregularities and grooving up to 2 mm depth  
IP55 protection degree guaranteed with control devices or other modular devices which allows the lid closure in ordinary performing conditions



Za raspoloživost kontaktirajte Ave distributere  
For availability please contact sales dept.



Dostupni dok se ne rasprodaju zalihe  
Available until stock out



Proizvod za pravougaone kutije britanskog standarda  
Product for British standard rectangular box



Proizvod za izvoz  
For Export only

Pogodne su za sve module nove serije Sistema 44 (Domus Touch, Life Touch i Allumia Touch)  
 Suitable for every S44 module (Domus Touch, Life Touch and Allumia Touch)



Sistema 45



Poklopac sa "sočivima" za identifikaciju svetlosnih indikatora na modulima  
 Membrane with lenses for identification of illuminated devices



- ✓ Veliki otvor za prste radi lakšeg podizanja poklopcu
- ✓ Ležište za šraf za blokadu otvaranja
- ✓ Wide opening for fingers to ease opening
- ✓ Seat for anti-opening block screw

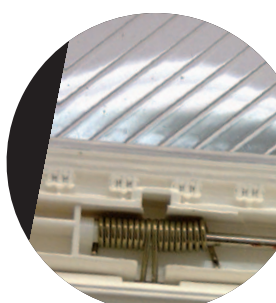

Tačke fiksiranja poklopcu za ram ojačane pomoću metalne šarke  
 Fixing points between lid and frame strenghten by metallic hinge



Mogućnost blokiranja poklopcu u otvorenom položaju  
 Possibility to block the lid in open position

160°  
 Ugao otvaranja poklopcu iznosi više od 160°  
 Opening angle of the lid over 160°



# Armature i kućišta

## Frames and Enclosures



Nadgradna kućišta otporna na vodu IP55 RAL 7035 sive boje - sa silikonskim poklopcem  
IP55 wall mounted boxes RAL 7035 with soft membrane cover - self-supporting

180



44ST01

Sistem blokiranja otvorenog poklopa  
OPEN BLOCK  
Locking system of the door open



44ST02

Sistem blokiranja otvorenog poklopa  
OPEN BLOCK  
Locking system of the door open



44ST03

Sistem blokiranja otvorenog poklopa  
OPEN BLOCK  
Locking system of the door open



44ST04

Sistem blokiranja otvorenog poklopa  
OPEN BLOCK  
Locking system of the door open

Kod Code	Opis Description	Info	€
44ST01	Nadgradno kućište otporno na vodu IP55 - 1 modul S44 1 module S44	<b>Novo</b>	24 24
44ST02	Nadgradno kućište otporno na vodu IP55 - 2 modula S44 2 modules S44	<b>Novo</b>	24 24
44ST03	Nadgradno kućište otporno na vodu IP55 - 3 modula S44 3 modules S44	<b>Novo</b>	20 20
44ST04	Nadgradno kućište otporno na vodu IP55 - 4 modula S44 4 modules S44	<b>Novo</b>	20 20
44ST080R	Nadgradno kućište otporno na vodu IP55 - 8 (4+4) modula S44 8 (4+4) modules S44	<b>Novo</b>	1 6
45ST99	Nadgradna razvodna kutija Wall mounted junction box		1 20
45ST99C	Poklopac IP55 ra razvodne kutije - postavlja se na bazu kutija sa IP40 zaštitom 45Q44, 45Q44V, 45Q48V, 45Q480R, 45Q4120R ili IP55 45ST04, 45ST080R IP55 junction box lid - to be fixed on IP40 enclosures codes 45Q44, 45Q44V, 45Q48V, 45Q480R, 45Q4120R or IP55 code 45ST04, 45ST080R		1 10

**Napomena:** stepen zaštite IP55 je garantovan uz upotrebu komandnih uređaja i drugih modularnih uređaja koji omogućavaju da poklopac ostane zatvoren za vreme uobičajenog rada

**Note:** IP55 protection degree guaranteed with control devices or other modular devices which allows the lid closure in ordinary performing conditions



45ST99C









44ST080R

Sistem blokiranja otvorenog poklopa  
OPEN BLOCK  
Locking system of the door open



45ST99

### Pribor za nadgradna kućišta IP55 Accessories for IP55 wall mounted enclosures

Cod. Code	Descrizione Description	Info	€
 45RD02	45RD02 Spojnica za kutije - montira se na predviđene otvore Ø 24 mm Box coupler - to be fixed on breakable holes Ø 24mm	10	10
 45PC00	45PC00 Univerzalna uvodnica za cevi/kablove - montira se na predviđene otvore Ø 24 mm Universal threaded conduit entry - to be fixed on breakable holes Ø 24mm	10	10
 45MM03	45MM03 Priključak za uzemljenje Earth terminal	500	500
 45PRC01	45PRC01 Uvodnica za kablove Ø 10/14mm - montira se na predviđene otvore Ø 24mm Cable gland for cables Ø 10/14mm - to be fixed on breakable holes Ø 24mm	10	10
 45PRT20	45PRT20 Uvodnica za cevi Ø 20mm - montira se na predviđene otvore Ø 24mm Tube gland for tubes Ø 20mm - to be fixed on breakable holes Ø 24mm	10	10
 45RD03	45RD03 Spojnica za kutije sa prolazom za kablove - montira se na predviđene otvore Ø 24mm Box coupler for cables passage - to be fixed on breakable holes Ø 24mm	10	10
 45TPST	45TPST Poklopac od izolacionog materijala Ø 13 mm - garantuje stepen zaštite IP55 na kućištima na čijoj bazi je predviđeno ležište za postavljanje šrafa za fiksiranje na zid Screw cover made of insulating material Ø 13 mm suitable to guarantee the IP55 protection degree on the enclosures with seat for the screw to be fixed on the wall	50	50

na upit upon request

**Napomena:** 45TPST minimalna narudžbina 50kom

**Note:** 45TPST minimum quantity 50 pcs



Za raspoloživost kontaktirajte  
Ave distributere  
For availability please contact  
sales dept.



Dostupni dok se ne  
rasprodaju zalihe  
Available until stock out



Proizvod za pravougaone  
kutije britanskog standarda  
Product for British standard  
rectangular box



Proizvod za  
izvoz  
For Export  
only

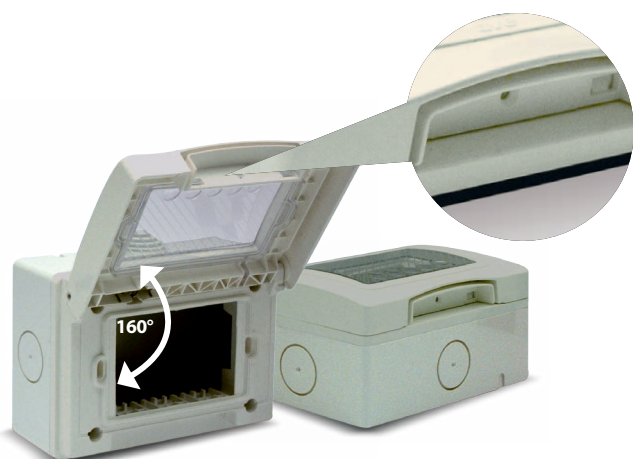

Ugao otvaranja poklopca iznosi više od 160°  
*Opening angle of the lid over 160°*

- ✓ Veliki otvor za prste radi lakšeg podizanja poklopca
- ✓ Ležište za šraf za blokadu otvaranja
- ✓ *Wide opening for fingers to ease opening*
- ✓ *Seat for anti-opening block screw*



Poklopac sa "sočivima" za identifikaciju svetlosnih indikatora na modulima  
*Membrane with lenses for identification of illuminated devices*

Tačke fiksiranja poklopca za ram ojačane pomoću metalne šarke  
*Fixing points between lid and frame strenghten by metallic hinge*

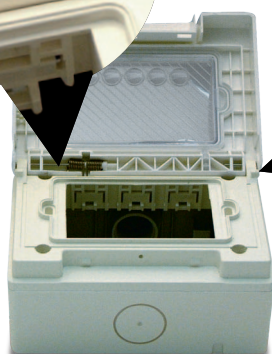
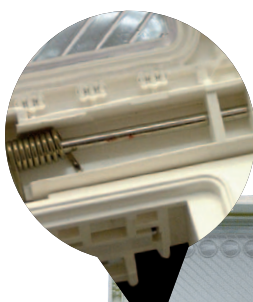

Mogućnost blokiranja poklopca u otvorenom položaju  
*Possibility to block the lid in open position*

**Sistem blokiranja otvorenog poklopca**  
**OPEN BLOCK**  
*Locking system of the door open*

Univerzalna uvodnica za kablove/cevi na gornjoj površini kućišta  
*Universal conduit/cable entry on the upper side of the base*

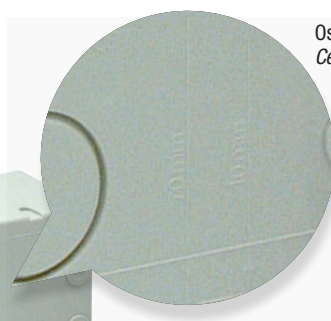

Osovinsko rastojanje za otvore za postavljanje na zid  
*Centre distance for wall mounting*

Površine pripremljene za lakše prosecanje otvora  
*Lightening to ease cutting*

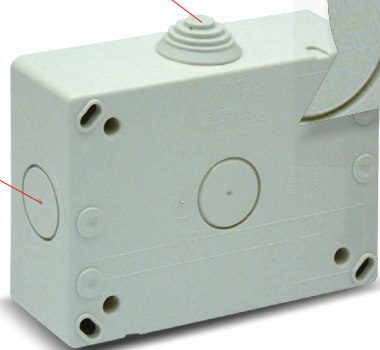

Ležište za priključak za uzemljenje 45MM03  
*Seat for earth terminal code 45MM03*

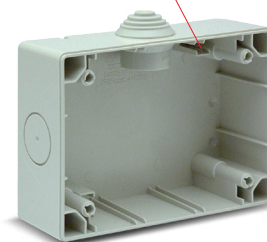





# Šeme montaže kutija, armatura i maski

## Installation diagrams of boxes, frames and front plates



Moguće kombinacije sa okruglom kutijom bez šrafova  
Possible combinations with round boxes without screws

181-a

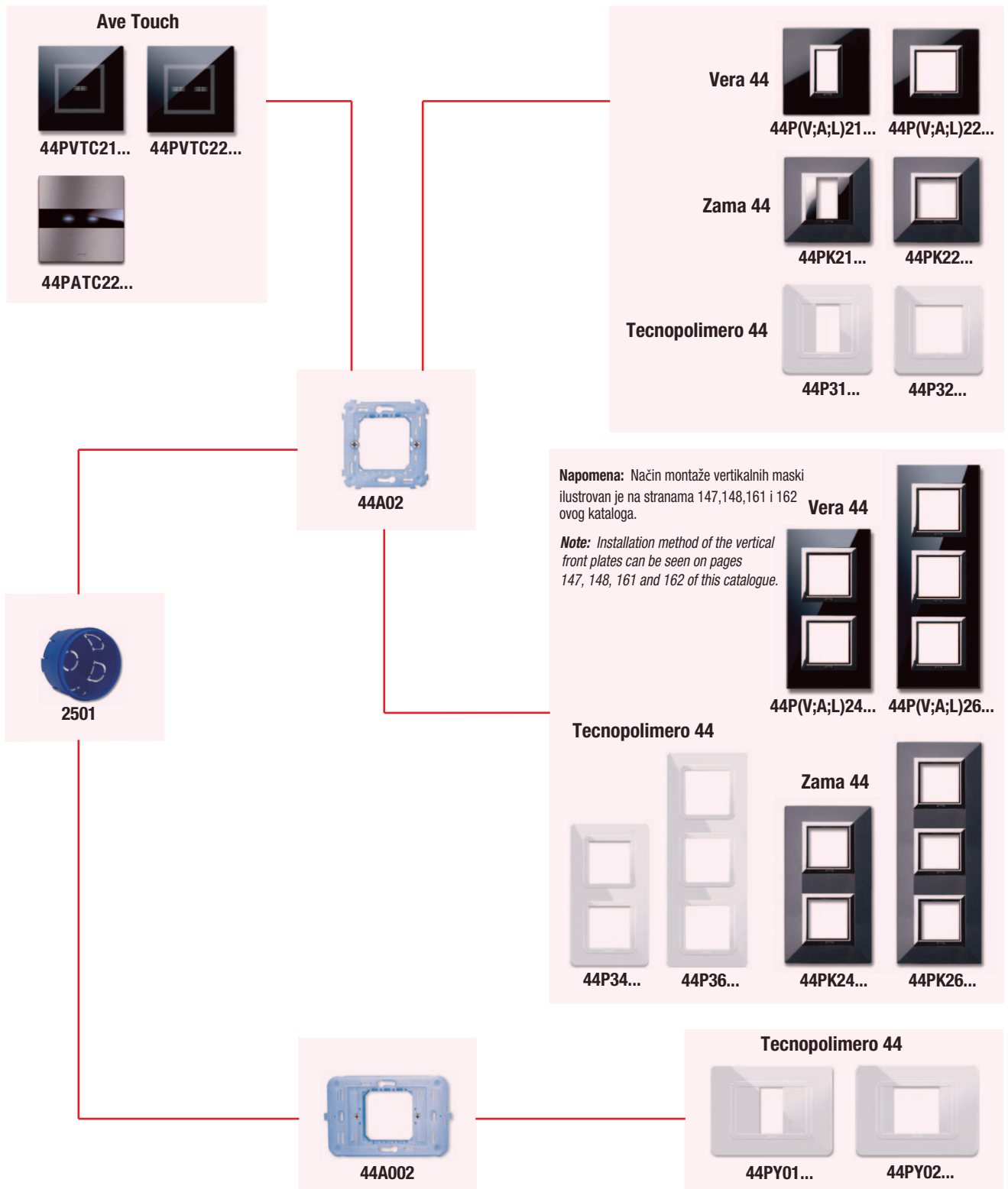

**Napomena:** ✓ Na kraju oznake maske umesto tačkica ubacite odgovarajuću oznaku boje (BL, NAL, ALS, RS, AO, BMC, GSM, B, GSL, OT, CHO itd.).  
✓ Sve raspoložive boje maski možete videti na stranim 14 i 130 - 135.

**Note:** ✓ Insert appropriate color code instead of dots at the end of the front plates code (BL, NAL, ALS, RS, AO, BMC, GSM, B, GSL, OT, CHO etc.).  
✓ All available front plate colors can be seen on pages 14 and 130 - 135.

**Moguće kombinacije sa okruglim i kvadratnim kutijama sa šrafovim**  
Possible combinations with round and square boxes with screws

181-b



Sistema 45

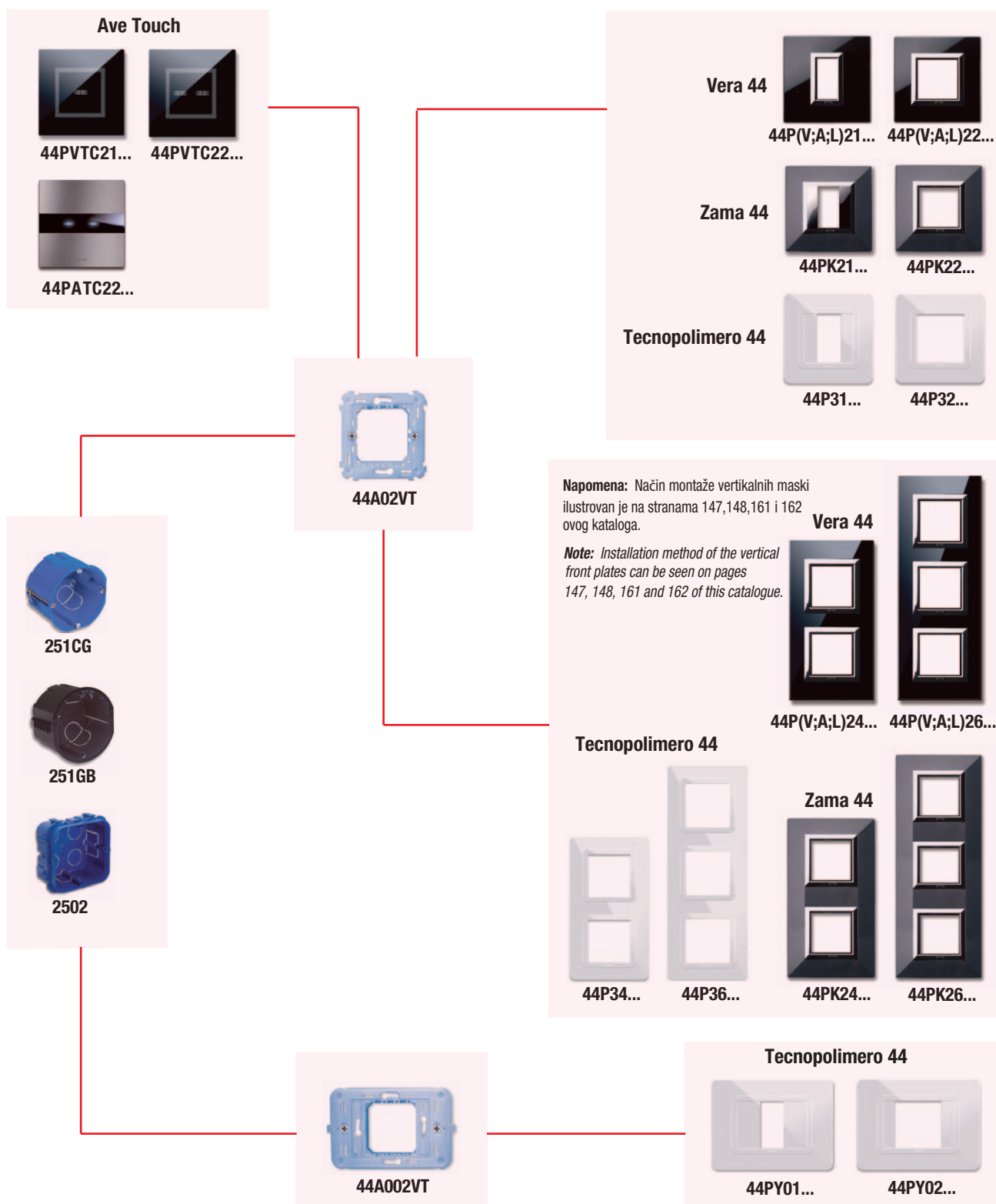

**Napomena:** ✓ Na kraju oznake maske umesto tačkica ubacite odgovarajuću oznaku boje (BL, NAL, ALS, RS, AO, BMC, GSM, B, GSL, OT, CHO itd.).  
✓ Sve raspoložive boje maski možete videti na stranama 14 i 130 - 135.

**Note:** ✓ Insert appropriate color code instead of dots at the end of the front plates code (BL, NAL, ALS, RS, AO, BMC, GSM, B, GSL, OT, CHO etc.).  
✓ All available front plate colors can be seen on pages 14 and 130 - 135.



# Šeme montaže kutija, armatura i maski

## Installation diagrams of boxes, frames and front plates

Moguće kombinacije sa pravougaonim kutijama za 3 modula  
Possible combinations with rectangular 3 modules boxes

181-c

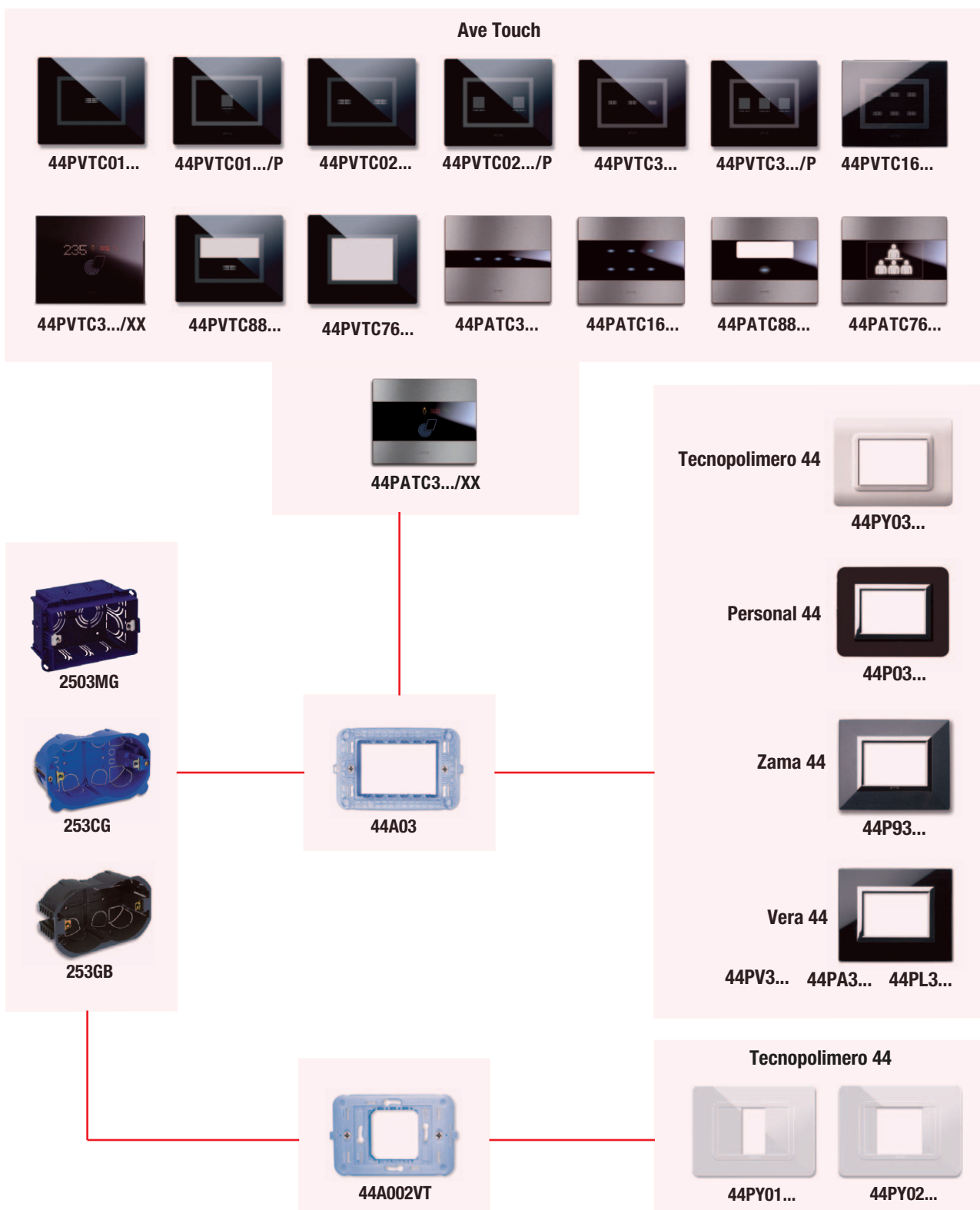

**Napomena:** ✓ Na kraju oznake maske umesto tačkica ubacite odgovarajuću oznaku boje (BL, NAL, ALS, RS, AO, BMC, GSM, B, GSL, OT, CHO itd.).  
✓ Sve raspoložive boje maski možete videti na stranama 14 i 130 - 135.

**Note:** ✓ Insert appropriate color code instead of dots at the end of the front plates code (BL, NAL, ALS, RS, AO, BMC, GSM, B, GSL, OT, CHO etc.).  
✓ All available front plate colors can be seen on pages 14 and 130 - 135.

Moguće kombinacije sa pravougaonim kutijama za 4 modula  
Possible combinations with rectangular 4 modules boxes



Sistema 45

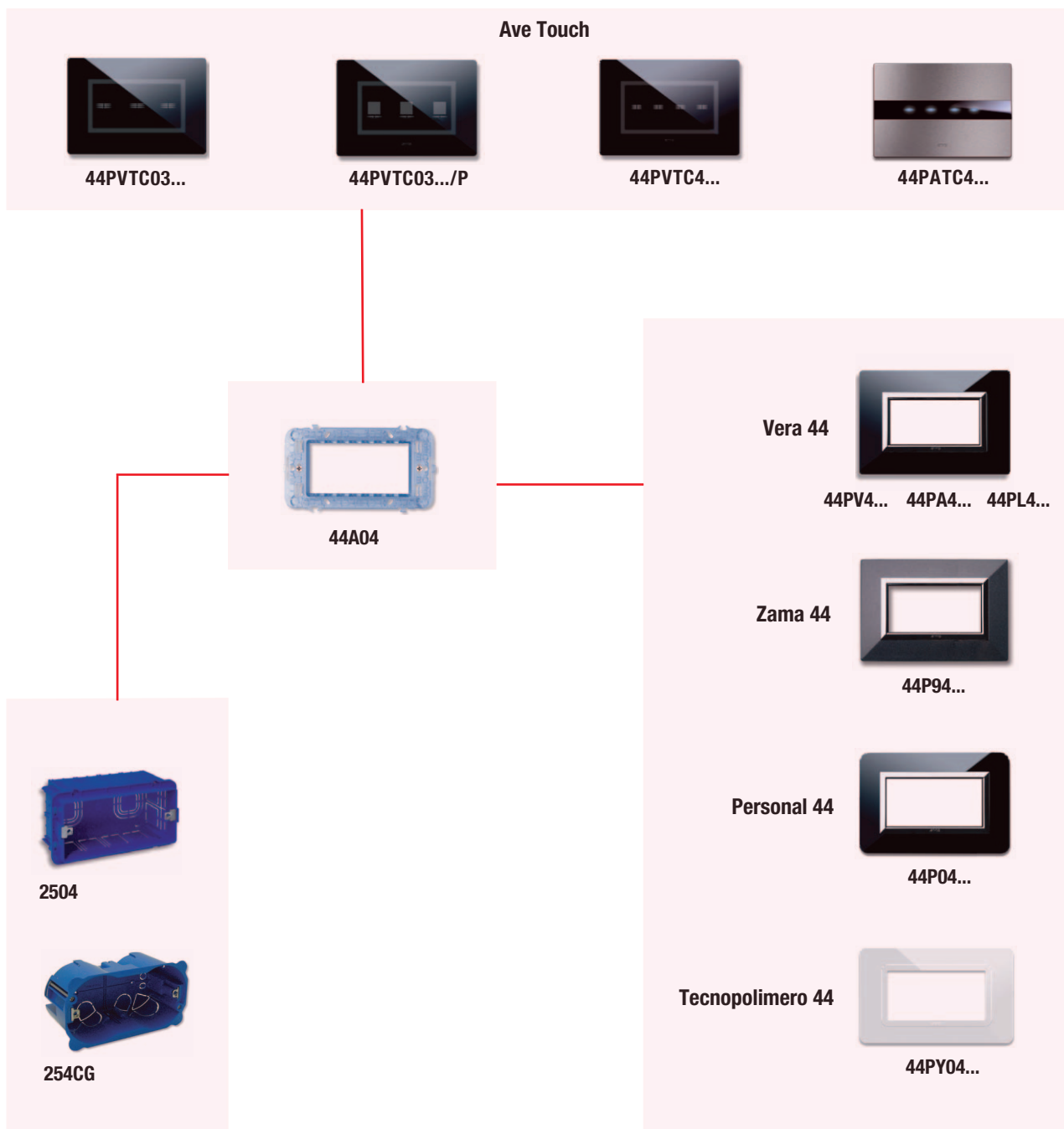

**Napomena:** ✓ Na kraju oznake maske umesto tačkica ubacite odgovarajuću oznaku boje (BL, NAL, ALS, RS, AO, BMC, GSM, B, GSL, OT, CHO itd.).  
✓ Sve raspoložive boje maski možete videti na stranama 14 i 130 - 135.

**Note:** ✓ Insert appropriate color code instead of dots at the end of the front plates code (BL, NAL, ALS, RS, AO, BMC, GSM, B, GSL, OT, CHO etc.).  
✓ All available front plate colors can be seen on pages 14 and 130 - 135.



# Šeme montaže kutija, armatura i maski

## Installation diagrams of boxes, frames and front plates

Moguće kombinacije sa pravougaonim kutijama za 7 modula  
Possible combinations with rectangular 7 modules boxes

181-e

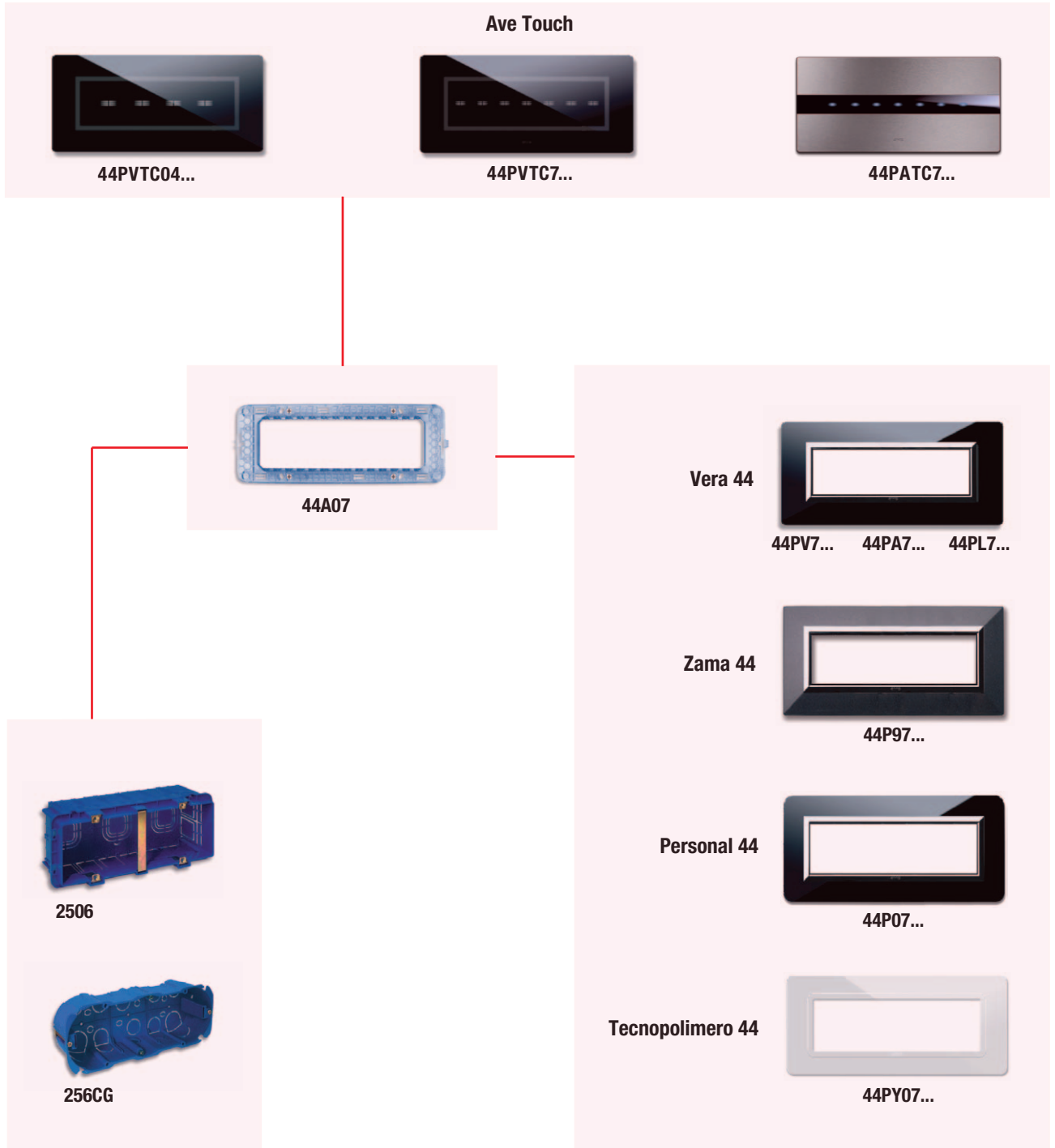

**Napomena:** ✓ Na kraju oznake maske umesto tačkica ubacite odgovarajuću oznaku boje (BL, NAL, ALS, RS, AO, BMC, GSM, B, GSL, OT, CHO itd.).  
✓ Sve raspoložive boje maski možete videti na stranama 14 i 130 - 135.

**Note:** ✓ Insert appropriate color code instead of dots at the end of the front plates code (BL, NAL, ALS, RS, AO, BMC, GSM, B, GSL, OT, CHO etc.).  
✓ All available front plate colors can be seen on pages 14 and 130 - 135.

**Moguće kombinacije sa pravougaonim kutijama za 6 (3+3) modula**  
*Possible combinations with rectangular 6 (3+3) modules boxes*

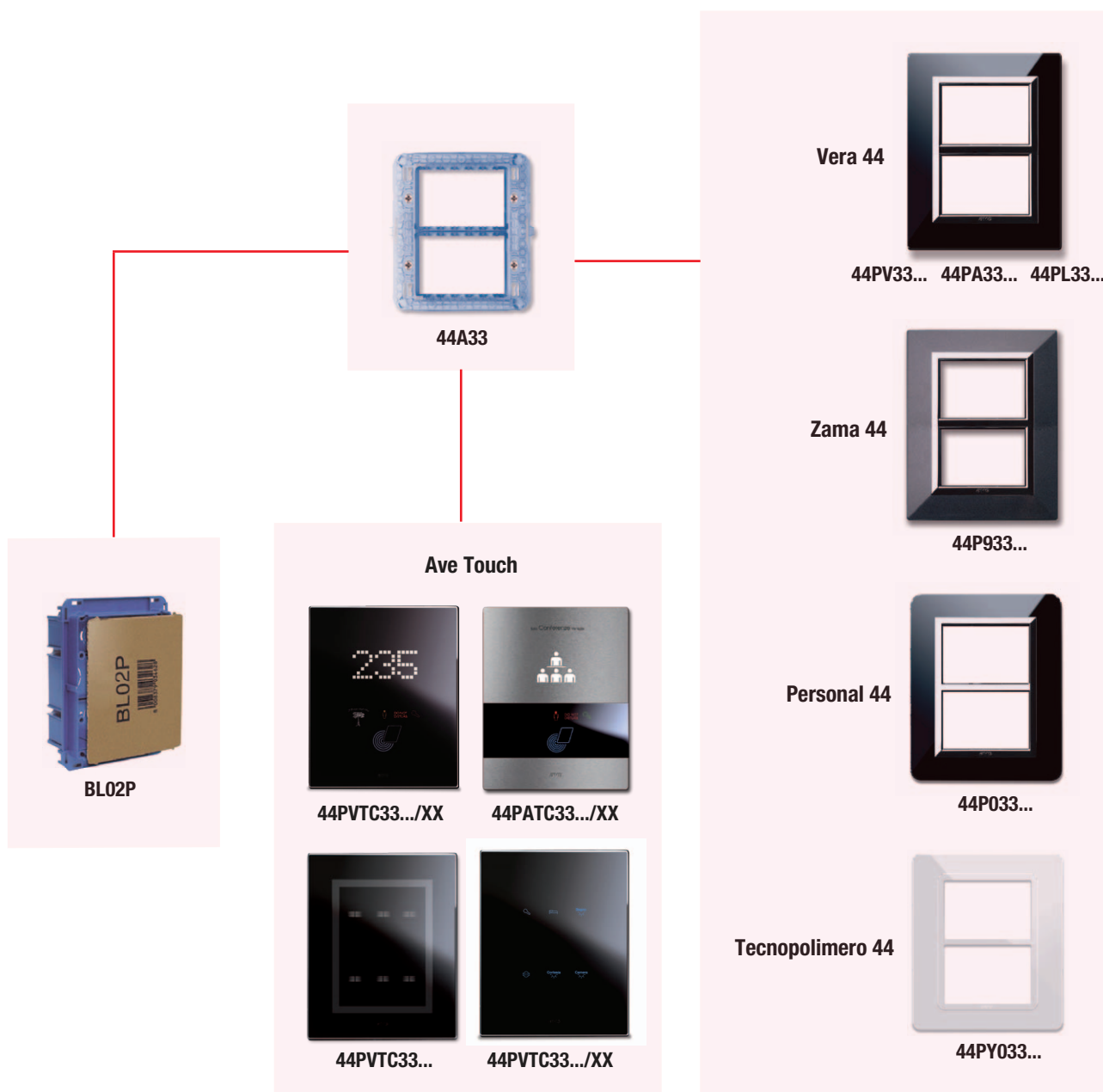

Sistema 45

- Napomena:**
- ✓ Na kraju oznake maske umesto tačkica ubacite odgovarajuću oznaku boje (BL, NAL, ALS, RS, AO, BMC, GSM, B, GSL, OT, CHO itd.).
  - ✓ Sve raspoložive boje maski možete videti na stranama 14 i 130 - 135.
  - ✓ Dodatne informacije o personalizujućim maskama „Ave Touch“ za 6(3+3) modula možete naći na stranama 68 i 69.

- Note:**
- ✓ Insert appropriate color code instead of dots at the end of the front plates code (BL, NAL, ALS, RS, AO, BMC, GSM, B, GSL, OT, CHO etc.).
  - ✓ All available front plate colors can be seen on pages 14 and 130 - 135.
  - ✓ Additional information about personalizaion of 6(3+3) modules “Ave Touch” front plates can be found on pages 68 and 69.



# Šeme montaže kutija, armatura i maski

Installation diagrams of boxes, frames and front plates

Moguće kombinacije sa pravougaonim kutijama za 12 (6+6) modula  
Possible combinations with rectangular 12 (6+6) modules boxes

181-g

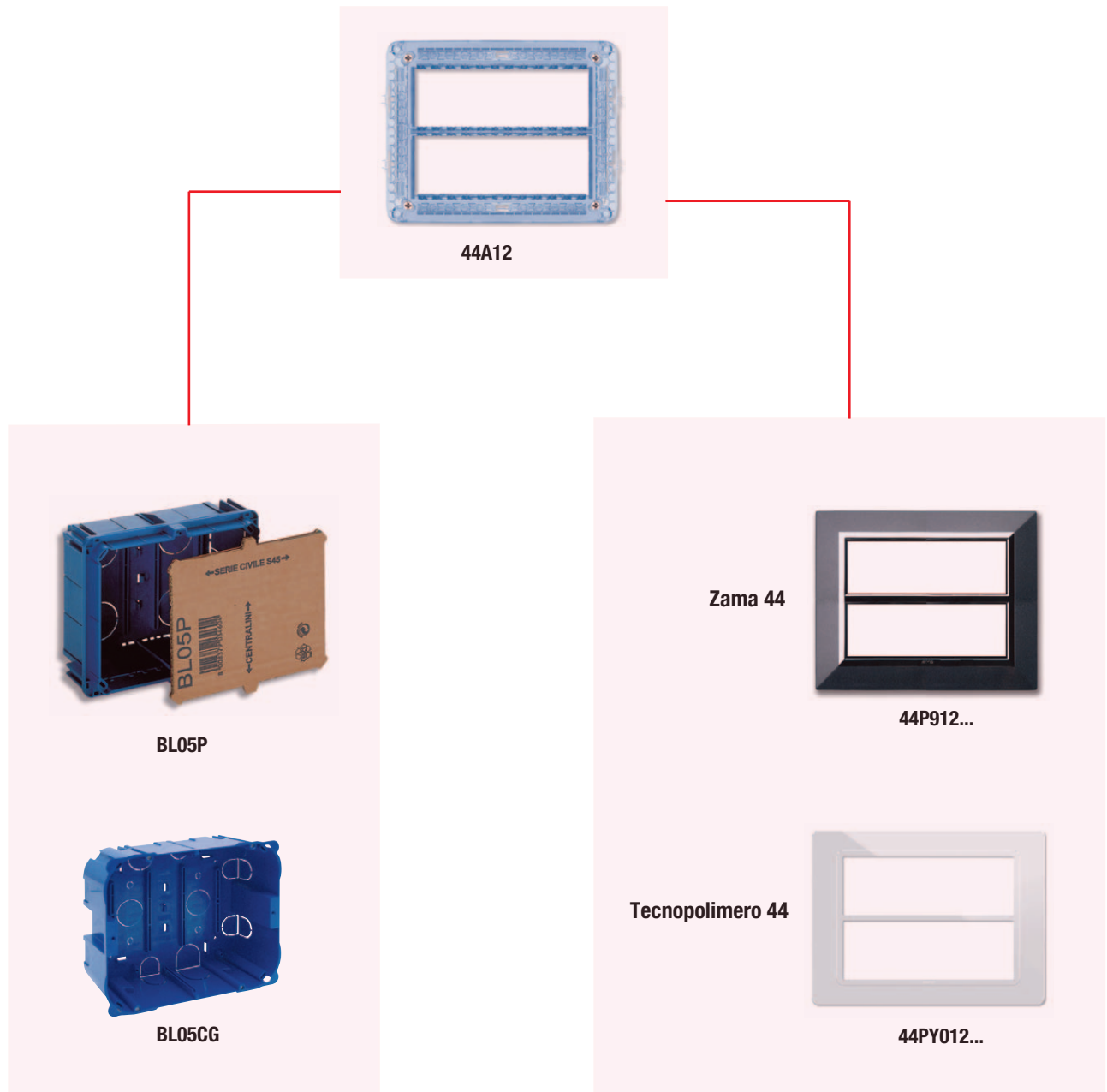

**Napomena:** ✓ Na kraju oznake maske umesto tačkica ubacite odgovarajuću oznaku boje (BL, NAL, ALS, RS, AO, BMC, GSM, B, GSL, OT, CHO itd.).  
✓ Sve raspoložive boje maski možete videti na stranama 130 - 135.

**Note:** ✓ Insert appropriate color code instead of dots at the end of the front plates code (BL, NAL, ALS, RS, AO, BMC, GSM, B, GSL, OT, CHO etc.).  
✓ All available front plate colors can be seen on pages 130 - 135.

**Moguće kombinacije sa specijalnim kutijama za montažu u ravni sa zidom za 3 modula**  
*Possible combinations with special 3 modules boxes for wall-lined instalation*

181-h



Sistema 45

**Ave Touch**



44PVTC01... 44PVTC01.../P 44PVTC02... 44PVTC02.../P 44PVTC3... 44PVTC3.../P 44PVTC16...



44PVT3.../XX 44PVT88... 44PVT76... 44PAT3... 44PAT16... 44PAT88... 44PAT76...



44PAT3.../XX

**Specijalne kutije za montažu „Ave Touch” maski u ravni sa zidom**  
*Special boxes for wall-lined instalation of “Ave Touch” front plates*

**Kutije za brzu montažu**  
*Boxes for rapid instalation*



SFM3

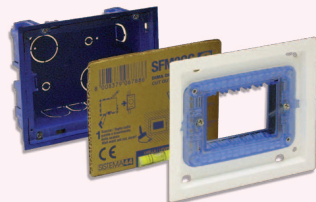

SFM3CG

**Kutije za preciznu montažu**  
*Boxes for high precision instalation*

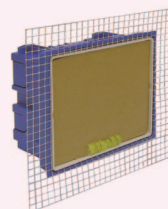

SFM3/HP

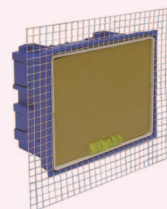

SFM3CG/HP

- Napomena:**
- ✓ Specijalne kutije isporučuju se u kompletu sa kartonskim šablonom, libelom (pričvršćenom na kutiju), ramom i armaturom 44A03 za 3 modula.
  - ✓ Postupak montaže „Ave Touch” maski u ravni sa zidom možete videti na stranama 33 i 35.
  - ✓ Na kraju oznake maske umesto tačkica ubacite odgovarajuću oznaku boje (BL, NAL, GO, RPL, V0). Sve raspoložive boje maski možete videti na strani 14.
- Note:**
- ✓ Special boxes are supplied with template, spirit level (attached to the box), paintable frame and “System 44” 3 module frame.
  - ✓ Wall-lined instalation procedure of “Ave Touch” front plates can be seen on pages 33 and 35.
  - ✓ Insert appropriate color code instead of dots at the end of the front plates code (BL, NAL, GO, RPL, V0). All available front plate colors can be seen on page 14.





Na tržištu se danas sve češće javljaju zahtevi za personalizacijom tipki za prekidače pomoću simbola ili natpisa, ili za personalizacijom maski pomoću simbola za identifikaciju (logotipa) čime se doprinosi kreiranju prestižnog imidža.

Kako bi izašao u susret ovim zahtevima, AVE nudi mogućnost reprodukcije natpisa, simbola, logotipa ili specifičnih oznaka na ceo asortiman maski ili na tipkama svih prekidača. Personalizacija se vrši pomoću tampon štampe ili laserske tehnologije, u zavisnosti od materijala na kome se vrši reprodukcija. Ako se personalizacija vrši pomoću nekog od simbola ili natpisa iz tabele koje su prikazane na narednim stranicama (Tabele 1, 2, 3 i 4) nakon koda proizvoda koji se želi personalizovati, u narudžbini je dovoljno navesti "sa simbolom/natpisom br..." prema numeraciji koja je data u tabeli, i naznačiti poziciju na kojoj simbol ili natpis treba da bude reprodukovani (npr. na sredini, gore, dole i sl.) i to prema šemi koja je prikazana na slikama 1, 1A, 1B, 1C, 1D (Sistem 44) i 2, 2A, 2B, 2C, 2D (Sistem 45). Ukoliko se vrši reprodukcija specifičnih logotipa ili oznaka neophodno je dostaviti film ili štampani otisak onoga što se reprodukuje, u dva ili tri puta većoj razmeri od one koja će biti reprodukovana. Logotipi ili oznake mogu se dostaviti i u elektronskom zapisu (na CD ili DVD) u JPG ili TIF formatu, zajedno sa primerkom za reprodukciju odštampanim na papiru. U tom slučaju, nakon koda proizvoda koji se želi personalizovati, u narudžbini je potrebno naznačiti poziciju na kojoj simbol ili natpis treba da bude reprodukovani (npr. na sredini, gore, dole i sl.) i to prema šemi koja je prikazana na slikama 1, 1A, 1B, 1C, 1D (Sistem 44) i 2, 2A, 2B, 2C, 2D (Sistem 45). Molimo vas da simbole ili natpise koje želite reprodukovati ne šaljete u vidu fotokopije ili faksom.

More and more often today, the market requests the possibility to personalize the front part of the covers with symbols or inscriptions, or the personalization of the front plates with identifying marks. Those marks are necessary to answer to the requirements of prestige and image. In order to face these requirements, Ave offers the possibility to reproduce inscriptions, symbols, logos or special marks on all the range of front plates or on the front part of all the keys. The personalization is realized by tampography press or by laser technology, in accordance with the material which the personalization is requested on.

If you can find the symbol or the inscription in the below charts, you only need to indicate in your order, after the product code to personalize, "with symbol/inscription n°..." according to the numbering shown in the charts, and to indicate the position where you wish the symbol or the inscription has to be reproduced (i.e. in the centre, top, bottom, etc.) according to the plan in fig. 1, 1A, 1B, 1C, 1D (System 44) e 2, 2A, 2B, 2C, 2D (System 45). For special logos or marks it is necessary to supply the film or printed publication of the object to reproduce, realized in a scale two or three times higher than the one to reproduce. The logos or marks can be supplied also on computer support (CD or DVD) in JPG or TIF format, together with a print on paper. In this case in the order, after the code of the product to personalize, simply indicate the position where the brand should be placed (i.e. in the centre, top, bottom, etc.) according to the plan in fig. 1, 1A, 1B, 1C, 1D (System 44) e 2, 2A, 2B, 2C, 2D (System 45). Please do not send the object to reproduce on photocopy or by fax.

**Cene personalizacije MASKI**

*Prices for FRONT PLATES customization*

**Količina**

*Quantity*

**Cena (\*)**

*Price (\*)*

Do 20 kom.

*Until 20 pcs*

Od 21 kom. do 100 kom.

*From 21 pcs to 100 pcs*

Od 101 kom. do 500 kom.

*From 101 pcs to 500 pcs*

Preko 500 kom.

*Over 500 pcs*

**(\*) dodatna cena po komadu**

*(\*) additional charge for every piece*

Obratite se najbližem AVE distributeru

Boje koje nisu na raspolaganju u zalihama, mogu se naručiti.

Za uslove isporuke, molimo vas da kontaktirate Ave distributere.

*The colours that are not available in stock can be supplied upon order.*

*For delivery terms, please contact Ave agencies.*

**Cene personalizacije TIPKI**

*Prices for ROCKERS customization*

**Količina**

*Quantity*

**Cena (\*)**

*Price (\*)*

Do 20 kom.

*Until 20 pcs*

Od 21 kom. do 100 kom.

*From 21 pcs to 100 pcs*

Od 101 kom. do 500 kom.

*From 101 pcs to 500 pcs*

Oltre i 500 pz.

*Over 500 pcs*

**(\*) dodatna cena po komadu**

*(\*) additional charge for every piece*

Please call the nearest AVE distributor

**Primeri personalizacije**

**Customization examples**



**Maska Zama 44**

**Sistem 44**

**Zama 44 front plate**

**System 44**



**Tipka Domus Touch**

**Sistem 44**

**Domus Touch rocker**

**System 44**



**Maska Banquise**

**Sistem 45**

**Banquise front plate**

**System 45**

PERSONALIZACIJA TIPKI SISTEMA 44 SYSTEM 44 ROCKERS CUSTOMIZATION

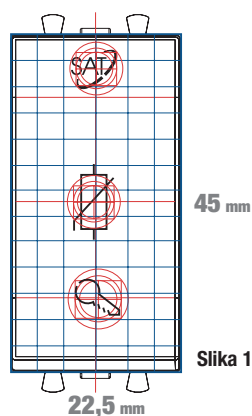

Raspoloživi simboli  
Available symbols

Tabela 1

1	2	3	4	5	6	7	8	9	10	11	12
13	14	15	16	17	18	19	20	21	22	23	24
25	26	27	28	29	30	31	32	33	34	35	36
37	38	39	40	41	42	43	44	45	46	47	48

PERSONALIZACIJA MASKI SISTEMA 44 SYSTEM 44 FRONT PLATES CUSTOMIZATION

VERA 44



Zona za personalizaciju  
Customizable zone

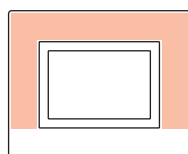

Slika 1A

ZAMA 44



Zona za personalizaciju  
Customizable zone

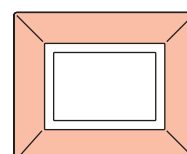

Slika 1B

PERSONAL 44



Zona za personalizaciju  
Customizable zone

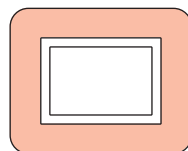

Slika 1C



SPECIJALAN SOFTVER SPECIFIC SOFTWARE  
Besplatno preuzmite sa sajta [www.ave.it](http://www.ave.it) softver za personalizaciju maski Personal.  
Download the free software to customize your Personal front plates from the website [www.ave.it](http://www.ave.it).

TECNOPOLIMERO 44



Zona za personalizaciju  
Customizable zone

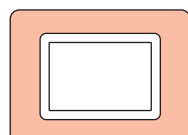

Slika 1D

ŠTAMPA PRINT  
Pomoću softvera odštampajte vaš dezen na perforiranim nalepticama.  
Use the software to print your texture on the pre-punched labels.



Da bi se zahtevala personalizacija maski sa kodovima koji se završavaju na "/XX", koje se obično koriste u hotelima, potrebno je slediti proceduru koja je opisana u nastavku.

Postoje 2 tipa maski koje se mogu personalizovati:

- za 3 modula 44PVTC3.../XX (str. 61 i 332 ovog kataloga)

- za 3+3 modula 44PVTC33.../XX (str. 61, 332 i 333 ovog kataloga)

Ove maske mogu biti personalizovane samo uz pridržavanje određenih pravila koja su navedena u nastavku:

a) logotipi/oznake/simboli/natpisi i sl. mogu se postaviti isključivo unutar zone koja je označena crvenom bojom (zona koja nije osvetljena) i/ili zelenom bojom (osvetljena zona) kao što je prikazano na slikama ispod (3, 3A, 3B, 3C);

b) ispisivanje brojeva soba hotela može se vršiti samo pomoću jednog od dva fonta koji su prikazani ispod i to samo u označenim zonama.

Uz zahtev za personalizacijom treba priložiti i grafičko rešenje, potpisano i overeno od strane naručioca, a koje za štampu priprema odeljene za grafički dizajn kompanije AVE kome se takav zahtev prosleđuje:

1. model i boja maske koja se želi personalizovati;

2. logotipi/oznake/simboli/natpisi i sl. koji se reprodukuju na masku kao i označena zona na kojoj će biti prikazani;

3. broj soba

4. bilo koja druga informacija koja može biti od koristi prilikom stvaranja grafičkom prikaza.

Troškovi

Za cene personalizacije maski obratite se najbližem AVE distributeru.

To require customization of plates with codes ending in "/XX", typically used in hotel plants it is required to proceed according to the following procedure:

There are 2 types of customizable formats:

- 3 modules code 44PVTC3.../XX (page 61 and 332 in this catalogue)

- 3+3 modules code 44PVTC33.../XX (page 61,332 and 333 in this catalogue)

These plates can be customized according to few constraints listed below:

a) logos/brands/symbols/texts etc... can be placed only inside the red dashed area (non illuminated area) and/or inside the green dashed area (illuminated area) as illustrated in figures below (fig. 3, 3A, 3B, 3C)

Attached to the order must be submitted also the graphic sketch, approved and signed with the stamp of the customer, prepared by the graphic dept. of AVE which has to receive with due advance:

1. model and colour of the plate to be customized;

2. possible logos/brands/symbols/texts etc... to be lasered on the plate and the indication of the position on the plate for the same;

3. possible room numbers;

4. whatever other information usefull to prepare the graphic sketch

Costs

For customization prices please call the nearest AVE distributor.

### Vreme izrade:

30 radnih dana od momenta odobranja grafičkog rešenja (koje je potpisao naručilac)

### Production lead time:

30 working days from graphic sketch approval

### Zona za personalizaciju

#### Laser zone

Zona za personalizaciju laserom koja ne svetli  
Not lighttable laser zone

Zona za personalizaciju laserom koja svetli  
Lighttable laser zone

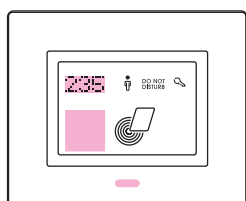

Slika 3

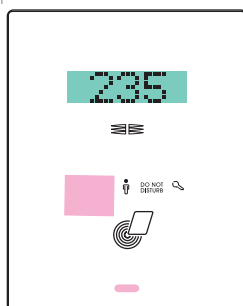

Slika 3A

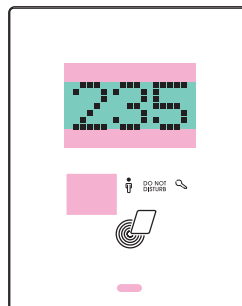

Slika 3B

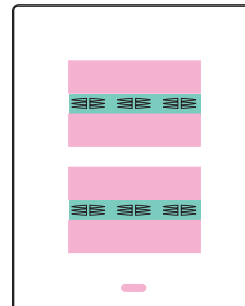

Slika 3C

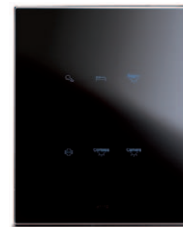
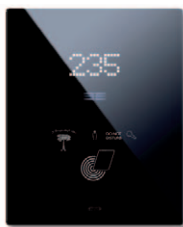

### RASPOLOŽIVI FONTOVI Available fonts

#### Subway Ticker

1 2 3 4 5 6 7 8 9 0

#### Subway Ticker condensed

1 2 3 4 5 6 7 8 9 0

#### Times Regular

1 2 3 4 5 6 7 8 9 0

#### Times condensed

1 2 3 4 5 6 7 8 9 0

## 1) OPŠTE NAPOMENE

Distributer je dužan da pažljivo rukuje ambalažom i da proizvode čuva na odgovarajući način, u prostorijama bez vlage i na temperaturi između -5°C i +40°C.

Distributer je dužan da obavesti svoje kupce o pravilnom načinu čuvanja proizvoda kompanije Ave S.p.A.

Distributer je dužan da proizvode prodaje u originalnoj ambalaži bez oštećenja, i ukoliko nije priloženo uputstvo, da kupca upozna sa instrukcijama za pravilnu upotrebu proizvoda kompanije Ave S.p.A. Ove instrukcije za upotrebu mogu se pronaći u katalogima, tehničkim šemama, brošurama.

Ukoliko distributer otpakuje proizvod pre prodaje, mora proveriti da li je proizvod neoštećen; ukoliko postoji sumnje u ispravnost proizvoda, ne treba ga koristiti već o tome obavestiti stručno lice - distributera.

Proizvodi kompanije AVE S.p.A jesu proizvodi koji zahtevaju instalaciju. Proizvode i dodatnu opremu mora da instalira stručno osoblje. Proizvodi moraju biti instalirani i korišćeni u skladu sa normama koje se primenjuju na različite vrste sistema, uzimajući u obzir i napomene koje su date u katalogu i uputstvima za upotrebu. Pre nego što se instalirani uređaji puste u rad, stručno osoblje mora da ispita tehničku ispravnost objekta, kako bi se utvrdila funkcionalnost i poštovanje bezbednosnih normi koji su propisani važećim zakonom.

Kompanija AVE ne snosi nikakvu odgovornost za nepravilnu upotrebu uređaja, kao i za nepoštovanje propisanih bezbednosnih normi, tehničkih karakteristika i uputstava za upotrebu. Oni proizvod čija upotreba nije u skladu sa normama i tehničkim karakteristikama koje propisuje EU, biće isporučeni kupcu samo ukoliko sam kupac u narudžbini naznači da su proizvodi namenjeni isključivo za upotrebu u zemljama koje nisu članice EU, kao i da su ispunjeni svi bezbednosni uslovi za instalaciju takvih proizvoda.

Kompanija AVE S.p.A zadržava pravo da, bez prethodne najave, unese izmene i poboljša kvalitet proizvoda koji su prikazani u katalogu i u cenovniku, a u cilju stalnog unapređenja proizvodnje, tehničke produktivnosti i povećanja standarda. U službi Tehničke podrške kompanije AVE S.p.A uvek možete dobiti svu potrebnu tehničku

• Ave S.p.A ne preuzima odgovornost za oštećenja ili eventualne povrede nastale usled nepridržavanja instrukcija za upotrebu koje su date u priručniku, usled nepravilne upotrebe, usled nepravilnog rukovanja bilo kojim delom uređaja, kao i usled upotrebe neoriginalnih rezervnih delova.

• Pažljivo pročitajte instrukcije za upotrebu pre nego što instalirate uređaj, dosledno ih sprovedite i pažljivo rukujte uređajem.

• Ambalaža proizvoda (plastiku, polistiren i sl.) se mora čuvati van domašaja dece jer može biti opasna.

• Ovaj proizvod je namenjen samo za upotrebu koja je naznačena u tehničkoj dokumentaciji. Korišćenje ovog proizvoda u bilo koju drugu svrhu može ga oštetiti i/ili može biti opasno.

• Uređaj se ne sme instalirati u uslovima gde postoji mogućnost eksplozije, niti u blizini zapaljivih gasova jer može biti opasno po zdravlje.

• Ukoliko je potrebna bilo kakva popravka, obratite se isključivo tehničkoj službi koja je ovlašćena od strane proizvođača

• Nakon što otpakujete proizvod, proverite njegovu ispravnost

• Instaliranje uređaja mora biti izvršeno u skladu sa bezbednosnim standardima i propisima

• Proizvođač ne snosi odgovornost za nepravilno i nestručno rukovanje uređajem

• Ne blokirajte ventilacione otvore ili otvore za ispuštanje toplote

• Instalater je dužan da korisniku pruži tehničke informacije o rukovanju uređajem u slučaju nastanka opasnosti, kao i da preda korisniku detaljno ilustrovano uputstvo za upotrebu proizvoda.

• Ukoliko se ne poštuju pravila koja su navedena iznad, može biti ugrožena bezbednost uređaja.

• Proverite da li unutar zidova na koje se postavljaju uređaji ne postoje izvori toplote kao što su dimnjaci ili sl.

• Održavanje: programirajte testiranje rada sistema, a naročito obratite pažnju na efikasnost uređaja za bezbednost (detektor curenja gasa, detektor curenja vode, magnetotermički detektori i sl.)

• Sve ono što nije eksplicitno navedeno u ovom uputstvu, nije dozvoljeno

Kompanija Ave S.p.A ne preuzima odgovornost za eventualna oštećenja ili povrede koje mogu nastati direktno ili indirektno, usled nepoštovanja svih mera opreza koje su propisane u tehničkoj dokumentaciji proizvoda, a naročito za nepoštovanje upozorenja koja se odnose na instalaciju i upotrebu proizvoda.

## 2) UPOZORENJA, GARANCJE I ŽALBE

Testiranje i proveru tehničke ispravnosti svih proizvodi kompanije AVE S.p.A vrši služba za proveru kvaliteta naše kompanije i svi proizvodi su proizvedeni u skladu sa propisima. Ukoliko se pravilno koriste, ovi proizvodi su bezbedni za ljude i okolinu. Kompanija AVE S.p.A daje garanciju na ispravnost svojih proizvoda na 5 godina, osim za proizvode iz "Zelenog odeljka" ovog kataloga iz oblasti Sigurnosni sistemi (protivptovalni sistemi, sistemi za detekciju požara, alarmni sistemi, sistem za ozvučenje, uređaji za slučaj opasnosti) kao i za proizvode iz oblasti Domina hotelskog sistema (sistemi kućne automatike i hotelskog menadžmenta) za koje se daje garancija od 2 godine, u skladu sa zakonom o obavezama koje proističu iz važeće zakonske odredbe u Italiji. Ukoliko se isti proizvod nalazi u okviru "Zelenog odeljka" kao i u drugim delovima ovog kataloga, u svakom slučaju se primenjuje garancija od 2 godine.

Period od 5 godina garancije počinje da se računa od momenta predaje robe od strane kompanije AVE S.p.A. Za proizvode iz "Zelenog odeljka" garancija počinje da se računa od momenta instalacije proizvoda, ali pod uslovom da postoji odgovarajuć potvrda o kupovini tog proizvoda koja je naslovljena na lice koje instalira proizvod/sistem. Ukoliko ne postoji takav dokument, period trajanja garancije se računa od datuma proizvodnje proizvoda.

Kupac gubi pravo na garanciju od 5 ili 2 godine, osim u slučaju prevare ili greške kompanije AVE S.p.A, ukoliko ne dokaže da je proizvod čuvan u skladu sa preporukama koje su date u tački 1) Opštih napomena, ili ukoliko je proizvod već instaliran, a ne postoji dokaz da je instalacija izvršena u skladu sa zakonskim odredbama D.P.R. 224/88 i u skladu sa važećim tehničkim normama.

U svakom slučaju AVE S.p.A ne snosi odgovornost za greške ili nedostatke koji su nastali nezavisno od kompanije. Garancija koja se odnosi na nedostatke i mane proizvoda ograničena je zamenu/popravku neispravnih delova. Bilo koja reklamacija koja se odnosi na nedostatke u kvalitetu, prividne kvarove i nedostatke i/ili one koji su lako uočljivi, kao i neslaganja u količini, moraju se uložiti pismenim putem u roku od 8 (osam) dana od prijema robe. Sve reklamacije na skrivene nedostatke moraju se uložiti pismenim putem u roku od 2 meseca od njihovog otkrivanja.

Usluge koje su obuhvaćene garancijom izvršiće kompanija AVE S.p.A ili neki od centara za pružanje tehničke pomoći koji su navedeni u nastavku. Ako se tehnička pomoć pruža u kući kupca, on je dužan da tehničkoj službi plati iznos u visini cene fiksnog telefonskog poziva prema važećoj tarifi. Ukoliko je korisnik doneo u centar za pružanje tehničke pomoći o svom trošku, usluga se ne naplaćuje. U nekim slučajevima, uz prethodnu saglasnost kompanije AVE S.p.A, kupac može poslati proizvod na popravku direktno u kompaniju AVE S.p.A. Pre nego što se proizvod pošalje na popravku, kompanija AVE S.p.A treba to da odobri. AVE S.p.A odlučuje da li će proizvod biti popravljen ili zamenjen. Troškovi slanja proizvoda na popravku snosi kupac. Ukoliko dođe do nesuglasica o tehničkoj ispravnosti proizvoda, konačan sud o tome daju tehnički stručnjaci kompanije AVE S.p.A. Proizvod treba poslati u kompaniju AVE S.p.A zajedno sa svim njegovim delovima, uključujući i ambalažu, u suprotnom, gubi se pravo na garanciju. Ako se proizvod prodaje kao sastavni deo kompleta pribora, treba vratiti ceo komplet proizvoda. AVE S.p.A ne može produžiti garanciju ukoliko su vršene bilo kakve popravke za vreme važenja garancije. Služba za pružanje tehničke pomoći ne vrši instalaciju uređaja, osim ako tako nije dogovoreno sa tehničkom službom i kupcem.

## 3) TEHNIČKE NAPOMENE ZA INSTALATERE

• Detaljnije informacije možete pronaći u uputstvu za upotrebu proizvoda na sajtu kompanije.

• Ave S.p.A ne preuzima odgovornost za oštećenja ili eventualne povrede nastale usled nepravilnog korišćenja uređaja od strane neovlašćenih lica

• Ave S.p.A ne preuzima odgovornost za oštećenja koja su nastala usled nepravilne instalacije uređaja od strane neovlašćenih lica

## AVE S.p.A.

Via Mazzini, 75 - 25086 Rezzato (Brescia) - Italy  
tel. +3903024981 - fax +390302792605  
info@ave.it

### Uffici Commerciali Italia

tel. 0302498337 - 0302498343 - fax 0302792837  
vendite@ave.it

### Export Department

ph.+3903024981 - fax +390302594595  
export@ave.it

### MEMBER OF:



*Za dodatne informacije  
posetite internet sajtove:*

[www.avespa.rs](http://www.avespa.rs)  
[www.ave.it](http://www.ave.it)  
[www.avetouch.it](http://www.avetouch.it)

pogledajte nove sajtove kućne automatike  
[www.avespa.rs/kucna-automatika.php](http://www.avespa.rs/kucna-automatika.php)  
[www.domoticaplus.it](http://www.domoticaplus.it)

## **INTEAM** *ave*

Servizio Assistenza Impianti Tecnologici Speciali

**INTEAM** con riferimento all'ampia gamma di prodotti che AVE è in grado di proporre al mercato, offre:

- supporto alla progettazione e prevenzione di impianti tecnologici speciali, fornendo schemi di impianto e di installazione apparecchi su planimetrie dal cliente fornite (formato file autocad)

- informazioni tecniche
- assistenza pre e post vendita
- supporto in cantiere.

**Numero Verde**  
**800 015 072**

## **PROC@P**

Software Creazione Capitolati

Il software PROC@P ha lo scopo di fornire le prescrizioni normative necessarie alla realizzazione di "Capitolati Tecnici per Impianti Elettrici e di Sicurezza".

[www.procap.it](http://www.procap.it)



**Elettricità  
Evoluta**  
dal 1904



International Trademark  
registration n°  
327040 - 942905 - 330600



AVE  
od 1904  
kontinuitet u inovacijama

AVE  
*since 1904 continuous innovation*



1904



2014



[www.ave.it](http://www.ave.it)  
800 015 072  
+39 030 24981



International Trademark  
registration n°  
327040 - 942905 - 330600



STA266-MAR14-E